

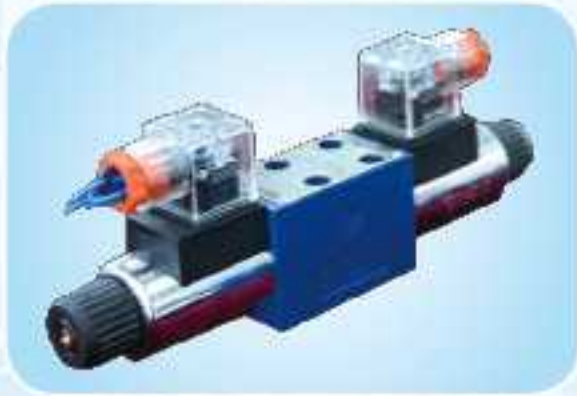

 **Huade**



Hydraulic valves



Directional Valves



Catalogue



BEIJING HUADE HYDRAULIC INDUSTRIAL GROUP CO.,LTD.

BEIJING HUADE HYDRAULIC INDUSTRIAL GROUP CO.,LTD.	Directional valves electro-hydraulically operated (new series)			RE 24751/12.2004
	Size 10 to 32	up to 35 MPa	up to 1100 L/min	

Features:

- Valves used to control the start, stop and direction of a fluid flow
- Electro-hydraulic operation (WEH), hydraulic operation (WH)
- For subplate mounting
- Spring or pressure-centred, spring or hydraulic offset
- Wet-pin DC or AC solenoids, optional
- Manual override, optional
- Electrical connection as individual or central connection
- Shifting time adjustment, optional
- Pre-load valve in the P-channel of the main valve, optional
- Auxiliary equipment:
 - Stroke adjustment at main spool, optional
 - Stroke adjustment and/or end position indicator, optional
 - Mechanical or inductive limit switch (proximity type) at the main spool, optional
- Porting pattern to Din 24 340 form A, ISO 4401 and CETOP-RP 121H



Pilot oil supply

4WEH . . . and 4WH . . .

The pilot oil supply is sourced externally via channel X from a separate circuit.

The pilot oil drain is led externally via channel Y to tank.

4WEH . . . E . . .

The pilot oil supply is sourced internally from channel P of the main valve.

The pilot oil drain is led externally via channel Y to tank. Port X in the subplate is plugged.

Change over from external to internal or from internal to external pilot oil supply (size 16): Remove the cover on the solenoid side "a", remove the plugs and turn end-for-end, insert plugs and re-place the cover.

4WEH . . . ET . . .

The pilot oil supply is sourced internally from channel P of the main valve.

The pilot oil drain is led internally via channel T to tank. Ports X and Y in the subplate are plugged.

4WEH . . . T . . .

The pilot oil supply is sourced externally via channel X from a separate circuit. The pilot oil drain is led internally via channel T to tank. Port Y in the subplate is plugged.

1 Plug screw M6-8.8 - pilot oil drain

2 Plug screws M6-8.8 - pilot oil supply

3 Plug screws M8-8.8 - for external sealing

Tightening torques M_A for cover fixing screws:

Size 16: 35 Nm

Size 25: 68 Nm

Tightening torque M_A for pilot valve fixing screws:

Sizes 10 to 32: 9 Nm

Throttle insert

The use of a throttle insert is required if the pilot oil supply in the P channel of the pilot valve is to be limited (see page 188).

This throttle is inserted in the P channel of the pilot valve.

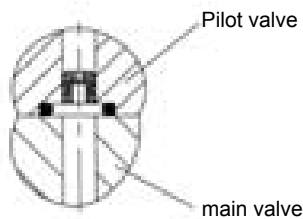

Size 10

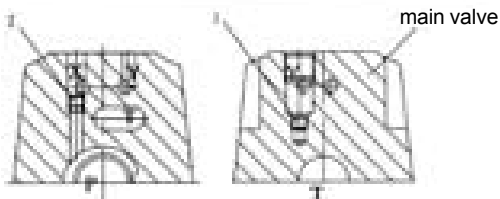

Pilot oil supply
external: 2 plugged
internal: 2 open

Pilot oil drain
external: 1 plugged
internal: 1 open

Size 16

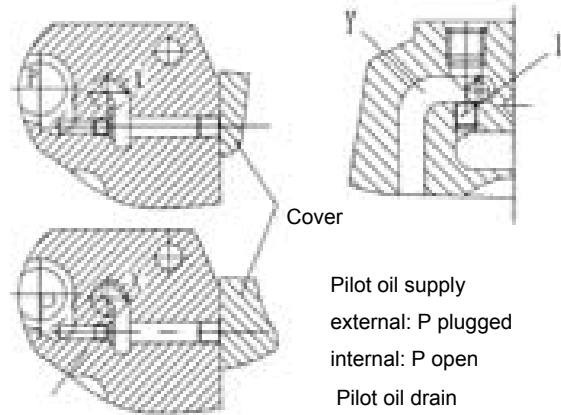

main valve

Pilot oil supply
external: P plugged
internal: P open
Pilot oil drain
external: 1 plugged
internal: 1 open

Size 25

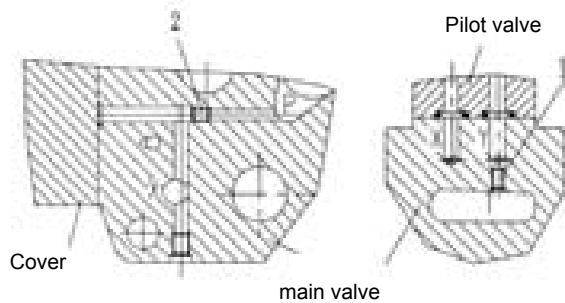

Cover

main valve

Pilot oil supply
external: 2 plugged
internal: 2 open

Pilot oil drain
external: 1 plugged
internal: 1 open

Size 32

Pilot valve

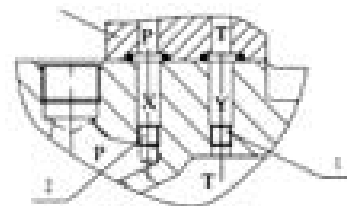

Pilot oil supply
external: 2 plugged
internal: 2 open

Pilot oil drain
external: 1 plugged
internal: 1 open

Functional, section

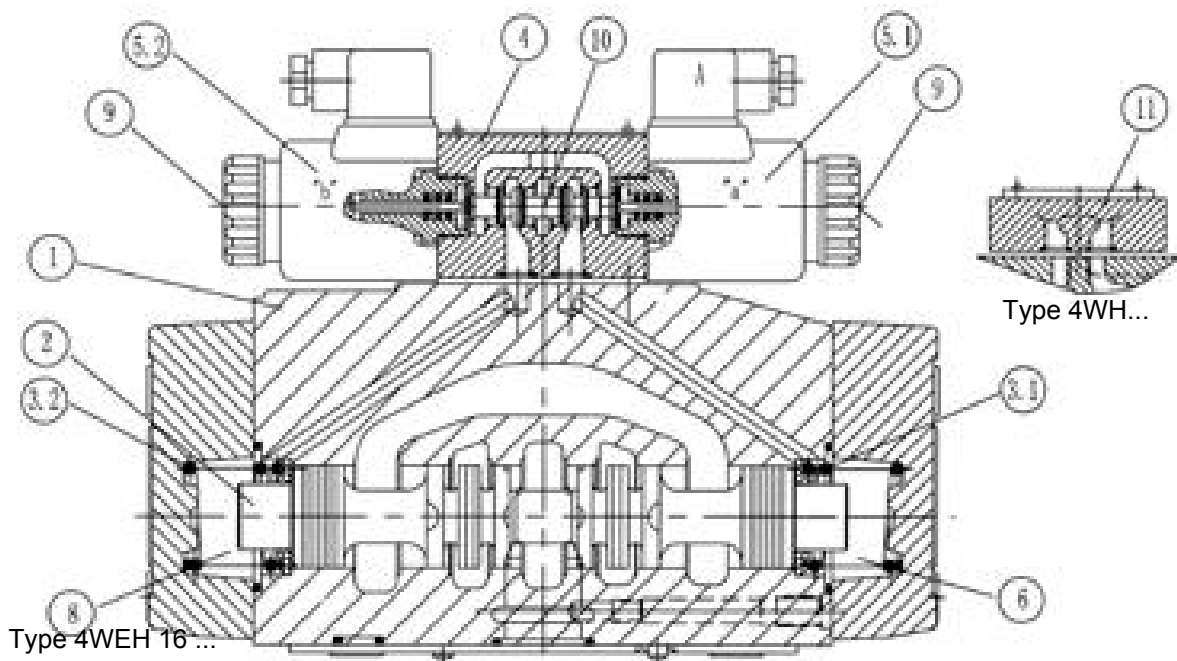

Directional valves type 4WEH...

Valves of type WEH are directional spool valves with electro-hydraulic operation.

They control the start, stop and direction of a fluid flow.

The directional valves basically consist of the main valve with housing (1), main control spool (2), one or two return springs (3.1) and (3.2), and the pilot valve (4) with one or two solenoids "a" (5.1) and/or "b" (5.2).

The main control spool (2) in the main valve is held in the neutral or in the initial position either by the springs or by means of pressure.

In the initial position, the two spring chambers (6) and (8) are connected to the tank without pressure via the pilot valve (4). The pilot valve is supplied with pilot fluid via the pilot line. The pilot oil supply can be either internal or external (external via port X).

When the pilot valve is operated, e.g. solenoid "a", the pilot spool (10) is shifted to the left and thus spring chamber (8) is pressurized with pilot pressure. Spring chamber (6) remains un-pressurized.

The pilot pressure acts on the left side of the main control spool (2) and pushes it against the spring (3.1). As a consequence, the ports P to B and A to T are connected in the main valve.

When the solenoid is de-energized, the pilot spool returns to its initial position (exception: detented spool). The spring chamber (8) is unloaded to tank.

The pilot oil is expelled from the spring chamber via the pilot valve into the Y channel.

The pilot oil supply and drain are internal or external (external via port Y).

An optional manual override (9) permits pilot spool (10) to be operated without energizing the solenoid.

Directional valves type 4WH...

Valves of type WH are directional spool valves with hydraulic operation.

They control the start, stop and direction of a fluid flow.

The directional valves basically consist of the valve housing (1), the main control spool (2), one or two return springs (3.1) and (3.2) in the case of valves with spring return or spring centring, and the pilot connecting plate (11).

The control spool (2) is operated directly by means hydraulic pressure.

The control spool (2) is held in the neutral or in the initial position either by springs or by means of pressure. Pilot oil supply and pilot oil drain are external (see page 2).

4/3-way directional valve with spring centring of the control spool

In this model, the main control spool (2) is held in the neutral position by two return springs (3.1) and (3.2). The two spring chambers (6) and (8) are connected to ports X and Y via the connector plate (11).

When one of the two ends of the main control spool (2) is pressurized with pilot pressure, the spool is moved to the shifted position. The required ports in the valve are then opened to flow.

When the pilot pressure is removed, the spring on the opposite side to the pressurized spool area causes the spool to return to its neutral or initial position.

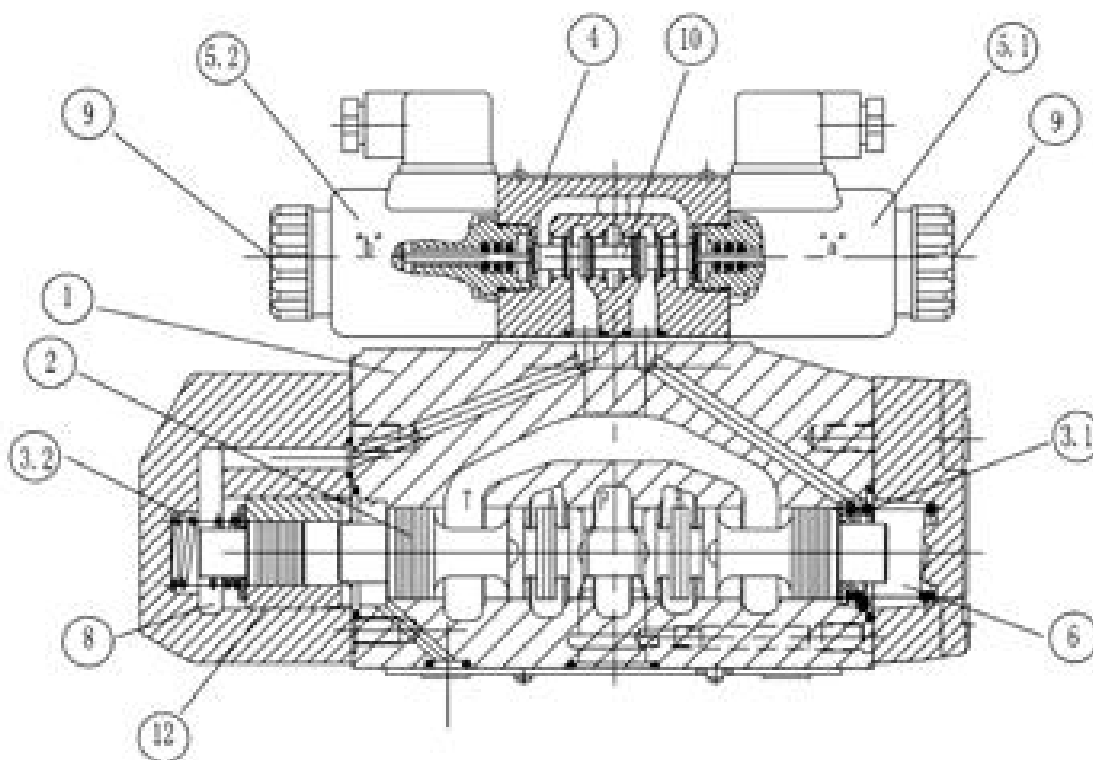

Type 4WEH 16 H...

4/3-way directional valve with pressure centring of the main control spool, type 4WEH... H

The main control spool (2) in the main valve is held in the neutral position by pressurization of the two front faces. A centring sleeve (12) is supported in the housing and holds the spool in position.

By removing the pressure from one of the spool ends, the main control spool (2) is moved to the shifted position.

The unloaded spool area displaces the returning pilot oil via the pilot valve into the Y channel (external).

Shifting time adjustment, pressure reducing valve, pre-load valve

Shifting time adjustment

In order to influence the shifting time of the main valve (1) a double throttle check valve (12) is installed. Change over from meter-in (13) to meter-out control (14): Remove the pilot valve 4 (leave the O-ring support plate (15) in place), rotate the throttle check valve (12) about its longitudinal axis and refit it, replace the pilot valve (4).

Tightening torque for screws (16)

$$M_A = 9 \text{ Nm.}$$

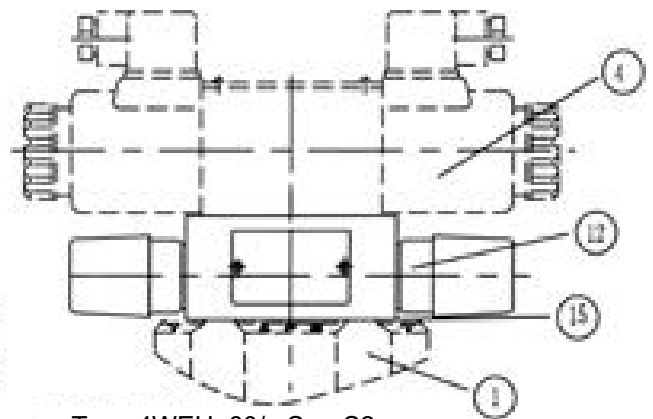
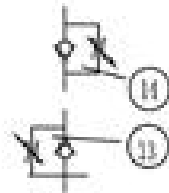

Type 4WEH..60/...S or S2

Pressure reducing valve "D3"

The pressure reducing valve (17) must be used if the pilot pressure is higher than 25 MPa. Thus, the secondary pressure is held constant at 4.5 MPa. When using a pressure reducing valve "D3" (17), a throttle insert "B10" must be installed in the P channel of the pilot valve.

Tightening torque for screws (16) $M_A = 9 \text{ Nm.}$

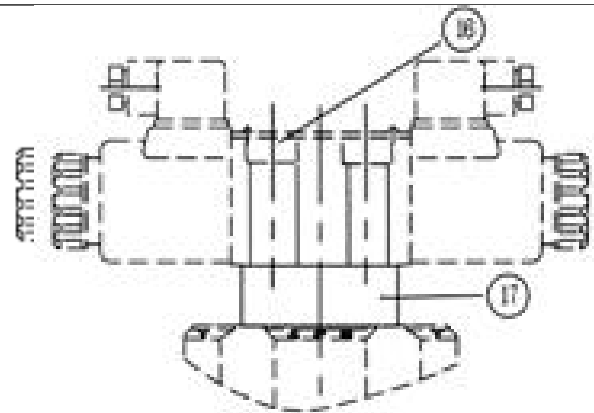

Type 4WEH..60/.../..D3

Pre-load valve (not for size 10)

In valves with pressureless by-pass and internal pilot oil supply, a pre-load valve (18) must be installed in the P channel of the main valve to build up the minimum pilot pressure.

The pressure difference of the pre-load valve must be added to the pressure difference of the main valve (see characteristic curve) in order to determine the actual value.

The cracking pressure of this valve is approx. 0.45 MPa.

$\Delta p/qv$ characteristic curve (measured at $v = 41 \text{ mm}^2/\text{s}$ and $t = 50^\circ\text{C}$)

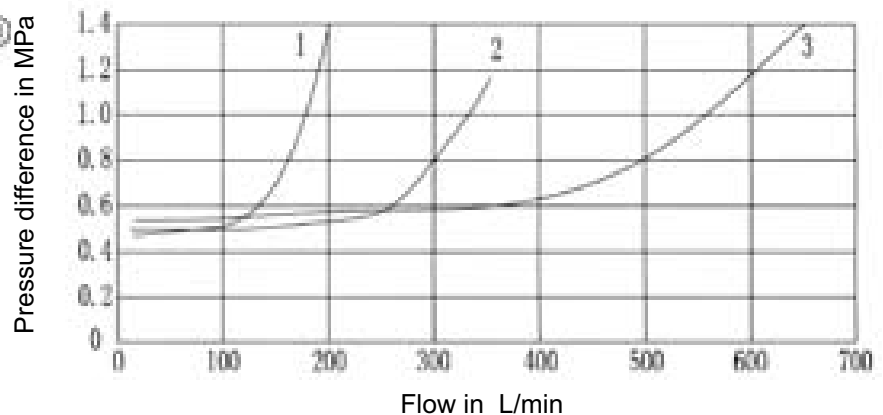
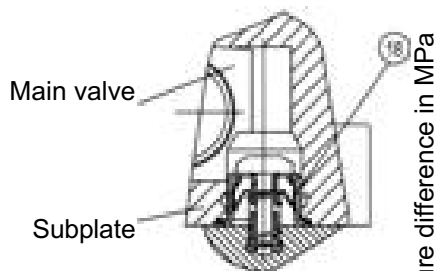

- 1 Size 16
- 2 Size 25
- 3 Size 32.

Ordering code

4 / B / *

pressure of operation
Up to 28 MPa = No code
Up to 35 MPa = H -

4-way design = 4

Types of operation
Electro-hydraulic = WEH
Hydraulic = WH

Size
Size 10 = 10
Size 16 = 16
Size 25 = 25
Size 32 = 32

Spool return
By means of springs = No code
Hydraulic = H

For symbols, see page 189

Series 40 to 49 (size 10)¹⁾ = 40
Series 60 to 69 (sizes 16, 25, 32)¹⁾ = 60

Technology of Beijing Huade Hydraulic = B

Spool return in the pilot valve for 2-position valve and 2 solenoids only possible with spools C, D, K, Z and hydraulic spool return in the main valve:
Without spring return = O
Without spring return with detent = OF

Pilot valve with wet-pin solenoids
Standard valve = A
High-performance valve = E

12 V DC = G12
220 V AC 50 Hz = W220-50
24 V DC = G24
DC solenoid commuting automatically = W220R

Further details in clear text

No code = mineral oils
V = phosphate ester

No code = Without pressure reducing valve
D3²⁾ = With pressure reducing valve

Pre-load valve (not for size 10)
No code = Without pre-load valve
P 4.5 = With pre-load valve

No code = Without throttle insert
B08 = Throttle Φ 0.8 mm
B10 = Throttle Φ 1.0 mm
B12 = Throttle Φ 1.2 mm
B15 = Throttle Φ 1.5 mm

Additional equipment NO. (see Additional equipment)

Type of electrical connection
(see dimensions of electrical connection on page 181)

No code = Without shifting time adjustment
S = Shifting time adjustment as meter-in control
S2 = Shifting time adjustment as meter-out control

No code = Pilot oil supply external, drain external
E = Pilot oil supply internal, drain external
ET³⁾ = Pilot oil supply internal, drain internal
T = Pilot oil supply external, drain internal
Type 4WH...only available as No code!
Versions ET and T as 3-position valve with pressure centring only possible if $p_{pilot} \geq 2 \times p_{tank} + p_{pilot min}$!

No code = Without manual override
N = With manual override
N9 = With protected manual override

- 1) Unchanged installation and connection dimensions
- 2) Only in conjunction with throttle insert "B10"
- 3) With internal pilot oil supply:
Minimum pilot pressure: Please note page 192!

- In order to avoid excessive pressure peaks, a throttle insert (B10) should be provided in the P port of the pilot valve .
- 4) Plug-in connectors have to be ordered separately

Symbols

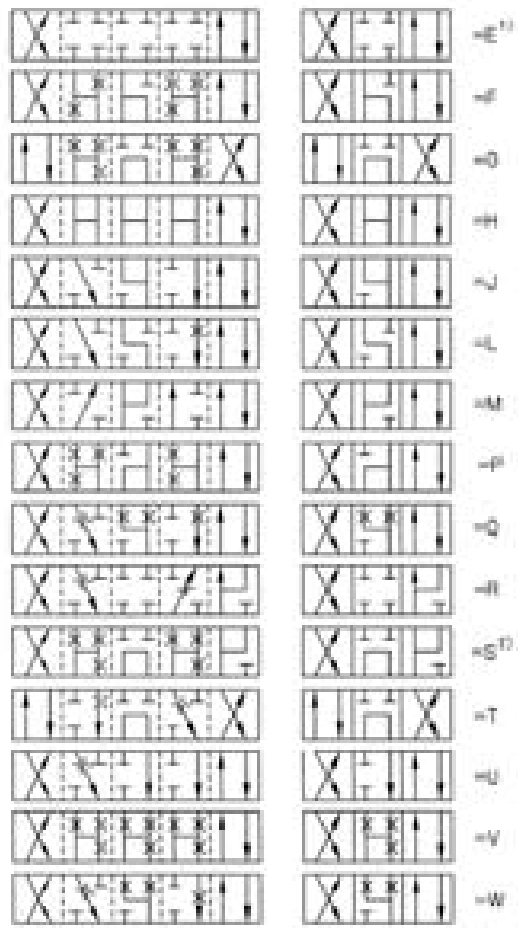
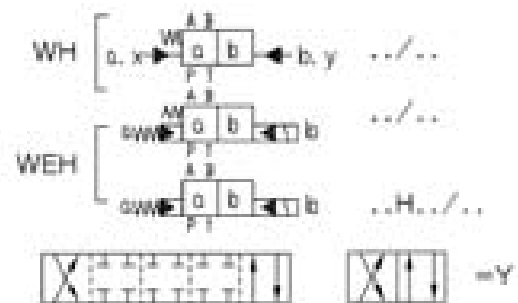
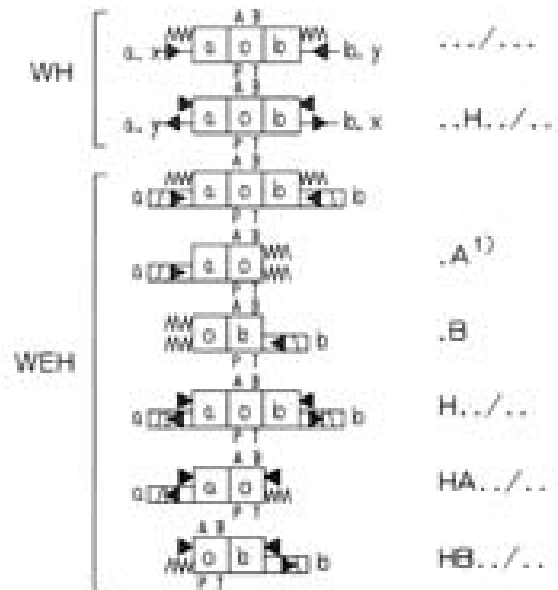
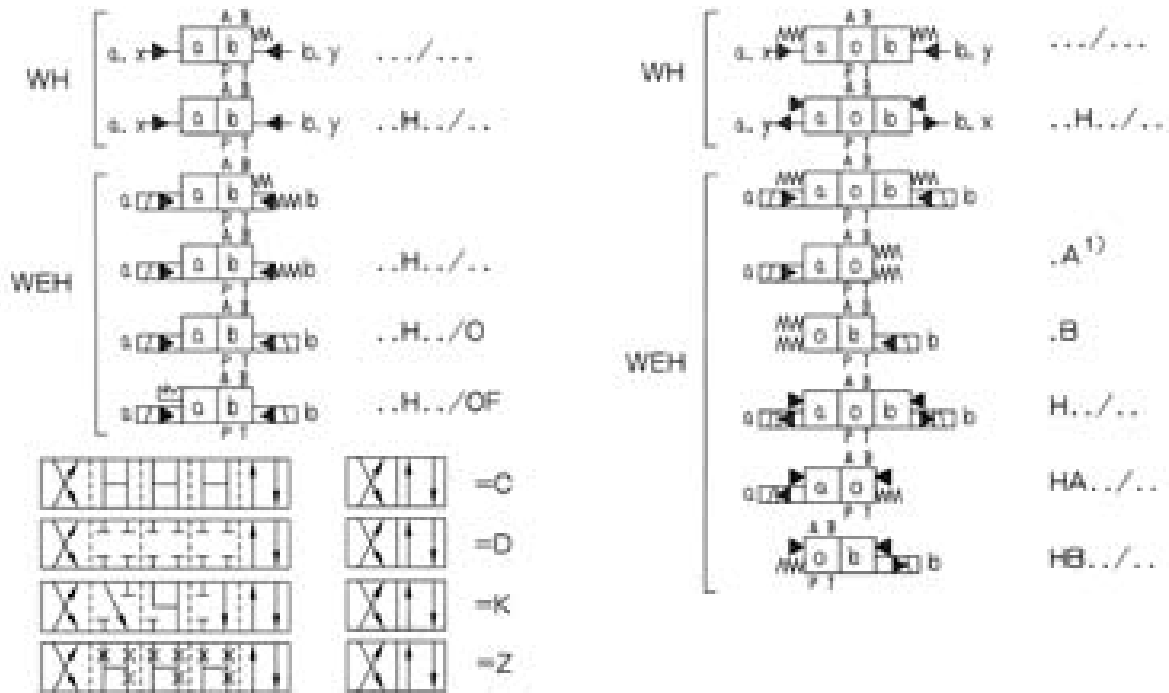





- 1) Example: Spool E, solenoid on side "a"
Order example:
H-4WEH 16 HEA60/6AG24N9ETSK4..B10..V..
- 2) Spool S only for size 16

Valve opening in neutral position for spools Q, V and W

Spool	Size	Valve opening in neutral position (in mm ²)			
		10	16	25 (type 4W.H 25.60B/...)	32
Q	P-A	-	-	-	-
	P-B	-	-	-	-
	A-T	13	32	83	78
	B-T	13	32	83	78
V	P-A	13	32	83	73
	P-B	13	32	83	73
	A-T	13	32	83	84
	B-T	13	32	83	84
W	P-A	-	-	-	-
	P-B	-	-	-	-
	A-T	2.4	6	14	20
	B-T	2.4	6	14	20

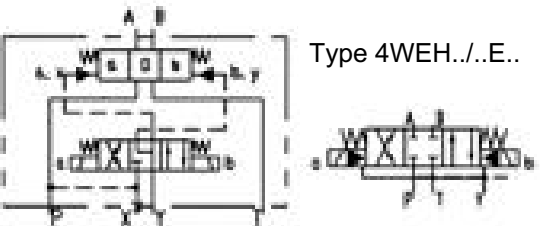
Detailed and simplified symbols for 3-position valves

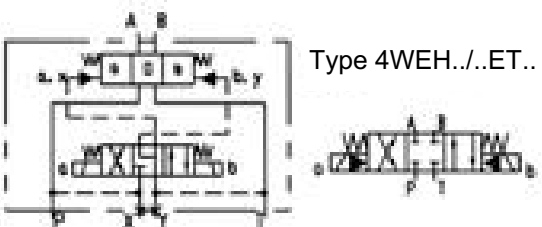
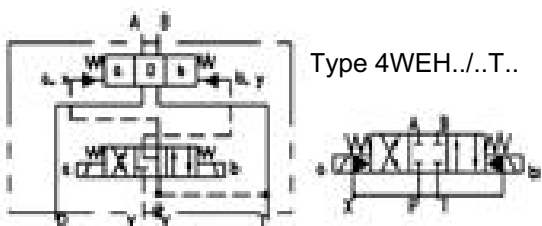
	Valve with spring-centred neutral position	Valve with pressure-centred neutral position only sizes 16, 25 (type 4W.H 25 .60/... and 32)
X = external; Y = external	 <p>Type 4WEH.../..</p>	 <p>Type 4WEH...H.../..</p>
X = internal; Y = external	 <p>Type 4WEH.../..E..</p>	 <p>Type 4WEH...H.../..E..</p>
X = internal; Y = internal	 <p>Type 4WEH.../..ET..</p>	<p>3-position valves, pressure-centred, preferably with external pilot oil supply and/or drain (No code, E) For the preconditions for internal pilot oil supply and/or drain (ET, T) see page 188 or 192.</p>
X = external; Y = internal	 <p>Type 4WEH.../..T..</p>	

Detailed and simplified symbols for 2-position valves

		Valves with spring offset		Valves with hydraulic offset	
X = external; Y = external	Type 4WEH.../...	Type 4WEH..H.../...	Type 4WEH..H/O...	Type 4WEH..H/OF...	
	Type 4WEH.../...E...	Type 4WEH..H.../...E...	Type 4WEH..H/O...E...	Type 4WEH..H/OF...E...	
	Type 4WEH.../...ET...	Type 4WEH..H.../...ET...	Type 4WEH..H/O...ET...	Type 4WEH..H/OF...ET...	
	Type 4WEH.../...T...	Type 4WEH..H.../...T...	Type 4WEH..H/O...T...	Type 4WEH..H/OF...T...	
X = internal; Y = external					
X = internal; Y = internal					
X = external; Y = internal					

Technical data (For applications outside these parameters, please consult us!)								
Sizes (ordering code)		10	16	25	32			
Operating pressure, max. Type 4WEH (MPa)		28	28	28	28			
- Port P, A, B	Type H-4WEH (MPa)	35	35	35	35			
- Port T	Pilot oil drain Y external (MPa)	31.5 ⁵⁾	25	25	25			
	Pilot oil drain Y internal ¹⁾	16 ⁶⁾ /21 ⁷⁾ DC 10 ⁶⁾ /16 ⁷⁾ AC						
- Port Y	- DC (MPa)	16 ⁶⁾ /21 ⁷⁾ DC						
Pilot oil drain external:	- AC (MPa)	10 ⁶⁾ /16 ⁷⁾ AC						
with version 4WH (MPa)		25						
Pilot pressure, max. (MPa) (With higher pilot pressures, a pressure reducing valve is required.)		25						
Pilot pressure, min. - Pilot oil supply X external, pilot oil supply X internal (not with spools: C, F, G, H, P, T, V, Z, S ²⁾)		H-4W...						
	3-position valve, spring-centred (MPa)	1.0	1.4	1.3	0.85			
	3-position valve, pressure-centred (MPa)	-	1.4	1.8	0.85			
	2-position valve, with spring offset (MPa)	1.0	1.4	1.3	1.0			
	2-position valve, with hydraulic offset (MPa)	0.7	1.4	0.8	0.5			
- pilot oil supply X internal (with spools C, F, G, H, P, T, V, Z, S ²⁾) (MPa)		4.5 ³⁾	4.5 ⁴⁾	4.5 ⁴⁾	4.5 ⁴⁾			
1) As 3-position valve with spring-centring only possible if $p_{pilot} \geq 2 \times p_{tank} + p_{pilot\ min}$		minimum pressure difference of 0.65 MPa from P to T.						
2) Spool S only for size 16		4) For spools C, F, G, H, P, T, V, Z, S (by means of a pre-load valve or a sufficiently large flow)						
3) For symbols C, F, G, H, P, T, V, Z internal pilot oil supply is only possible, if the flow from P to T in the neutral position (in a 3-position valve) or when the valve is moving through the neutral position (in a 2-position valve) is large enough to ensure a		5) Type 4WEH 10...: 28 MPa Type H-4WEH 10...: 31.5 MPa						
		6) Standard valve "6A"						
		7) High-performance valve "6E"						
Hydraulic fluid		Mineral oil (for NBR seal) or Phosphate ester (for FPM seal)						
Fluid temperature range (°C)		- 30 to + 80						
Viscosity range (mm ² /s)		2.8 to 500						
Cleanliness		Maximum permissible degree of contamination of the hydraulic fluid to NAS 1638 class 9. We therefore recommend a filter with a minimum retention rate of $\beta_{10} \geq 75$.						
Pilot oil volume for shifting operation :								
- 3-position valve, spring-centred (cm ³)		2.04	5.72	14.2	29.4			
- 2-position valve (cm ³)		4.08	11.75	28.4	58.8			
- 3-position valve, pressure-centred			WH	WEH	WH	WEH	WH	WEH
From neutral position to shifted position "a" (cm ³)		2.83	2.83	7.15	7.15	14.4	14.4	
From shifted position "a" to neutral position (cm ³)		2.9	5.73	14.18	7.0	29.4	15.1	
From neutral position to shifted position "b" (cm ³)		5.72	5.73	14.18	14.15	29.4	29.4	
From shifted position "b" to neutral position (cm ³)		2.83	8.55	19.88	5.73	43.8	14.4	
Pilot oil flow for shortest shifting time (L/min)		approx.35	approx.35	approx.35	approx.45.0			
weight	Valve with one solenoid (kg)	approx.6.4	approx.8.5	approx.17.6	approx.40.5			
	Valve with two solenoids, spring-centred (kg)	approx.6.8	approx.8.9	approx.18.0	approx.41.0			
	Valve with two solenoids, pressure-centred (kg)	approx.6.8	approx.8.9	approx.19.0	approx.41.0			
	Valve with hydraulic operation (4WH...) (kg)	approx.5.5	approx.7.3	approx.16.5	approx.39.5			
	Shifting time adjustment (kg)	approx.0.8						
	Pressure reducing valve (kg)	approx.0.4						
Installation position		optional; valve with hydraulic spool return "H"(spools C, D, K, Z, Y) horizontal						

Shifting times														
Shifting time = Contacting at the pilot valve up to start of opening of the control land in the main valve														
Size 10 Pilot valve series 50/A	Shifting time of the valve from neutral position to shifted position with AC (~) and DC (=) operation													
	at pilot pressure	(MPa)	~ 7=		~ 14=		~ 21=		~ 25=					
	- 3-position valve	(ms)	30	65	25	60	20	55	15	50				
	- 2-position valve	(ms)	35	80	30	75	25	70	20	65				
	Shifting time of the valve from shifted position to neutral position													
	- 3-position valve	(ms)	30											
	- 2-position valve	(ms)	35	40	30	75	25	30	20	25				
Size 16 Pilot valve series 60/E	Shifting time of the valve from neutral position to shifted position with AC (~) and DC (=) operation													
	at pilot pressure	(MPa)	~ 7=		~ 14=		~ 21=		~ 25=					
	- 3-position valve, spring-centred	(ms)	25...30	40	25...30	40	25...30	40	20...25	40				
	- 2-position valve	(ms)	30...35	55	30...35	55	30...35	55	25...30	50				
	- 3-position valve	Solenoid operated	a	b	a	b	a	b	a	b	a	b	a	b
	pressure-centred	(ms)	30	30	40	40	30	30	40	40	30	30	35	40
	Shifting time of the valve from shifted position to neutral position													
	- 3-position valve	(ms)	20 to 35 for ~ ; 30 for =											
	- 2-position valve	(ms)	35...50	45	35...50	45	30...45	40	30...45	35				
	- 3-position valve	from -	a	b	a	b	a	b	a	b	a	b	a	b
pressure-centred	(ms)	20...35	20	20...35	20	20...35	20	20...35	20	20...35	20			
Size 25 (4W, H 25 .60)	Shifting time of the valve from neutral position to shifted position with AC (~) and DC (=) operation													
	at pilot pressure	(MPa)	~ 7=		~ 14=		~ 21=		~ 25=					
	- 3-position valve, spring-centred	(ms)	50	85	40	75	35	70	30	65				
	- 2-position valve	(ms)	120	160	100	130	85	120	70	105				
	- 3-position valve	Solenoid operated	a	b	a	b	a	b	a	b	a	b	a	b
	pressure-centred	(ms)	30	35	55	65	30	35	55	65	25	30	50	60
	Shifting time of the valve from shifted position to neutral position													
	- 3-position valve	(ms)	40 to 55 for ~ ; 40 for =											
	- 2-position valve	(ms)	120	125	85	100	85	90	75	80				
	- 3-position valve	from -	a	b	a	b	a	b	a	b	a	b	a	b
pressure-centred	(ms)	30...50	30	35	30...50	30	50	30...50	30	35	30...50	30	35	
Size 32 Pilot valve series 50/A	Shifting time of the valve from neutral position to shifted position with AC (~) and DC (=) operation													
	at pilot pressure	(MPa)	~ 5=		~ 15=		~ 25=							
	- 3-position valve, spring-centred	(ms)	65	80	50	90	35	105						
	- 2-position valve	(ms)	100	130	75	100	60	115						
	- 3-position valve	Solenoid operated	a	b	a	b	a	b	a	b	a	b	a	b
	pressure-centred	(ms)	55	60	100	105	40	45	85	95	35	40	85	95
	Shifting time of the valve from shifted position to neutral position													
	- 3-position valve	(ms)	60 to 75 for ~ ; 50 for =											
	- 2-position valve	(ms)	115...130	90	85...100	70	65...80	65						
	- 3-position valve	from -	a	b	a	b	a	b	a	b	a	b	a	b
pressure-centred	(ms)	30...65	30	40	60...90	30	30	105...155	50	50				

Characteristic curves: Type 4WEH 10...(measured at $v = 41 \text{ mm}^2/\text{s}$ and $t = 50^\circ\text{C}$)

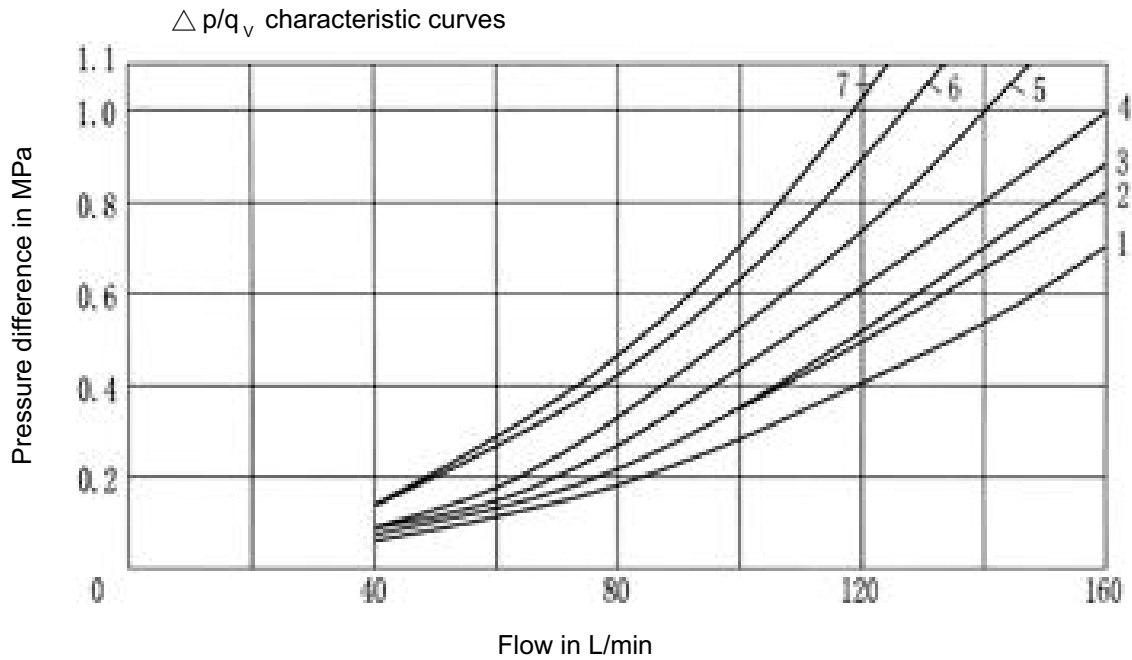

Spool	Shifted position				Spool	Neutral position		
	P-A	P-B	A-T	B-T		A-T	B-T	P-T
E,D,Y2	2	4	5	F	3	-	6	
F	1	4	1	4	G,T	-	-	7
G,T	4	2	2	6	H	1	3	5
H,C	4	4	1	4	L	L	3	- -
J,K	1	2	1	3	P	-	7	5
L	2		3	1	U	-	4	-
M	4	4	3	4				
Q,V,W,Z	2	2	3	5				
R	2	2	3	-				
U	3	3	3	4				
P	4	1	3	4				

Shifting performance limits: Type 4WEH 10...(measured at $v = 41 \text{ mm}^2/\text{s}$ and $t = 50^\circ\text{C}$)

2 and 3-position valves (Permissible flow q_v in L/min)			
Spool	Operating pressure p_{max} in MPa		
	20	25	31.5
E, J, L, M, Q, R, U, V, W, C, D, K, Z, Y	160		
H	160	150	120
G, T	160	160	140
F, P	160	140	120

General:

Attention!

The shifting performance limits shown are valid for applications with two directions of flow (e.g. from P to A and simultaneous return flow from B to T).

As a result of the flow forces occurring within the valve with only one direction of flow (e.g. from P to A with port B blocked) the permissible performance limits may be considerably lower!

(In the case of applications of this kind, please consult us.)

The performance limits were determined with the solenoid at operating temperature, 10% undervoltage and with no tank pre-loading.

Characteristic curves: Type 4WEH 16...(measured at $v = 41 \text{ mm}^2/\text{s}$ and $t = 50^\circ\text{C}$)

$\Delta p/q_v$ -characteristic curves-Spool E

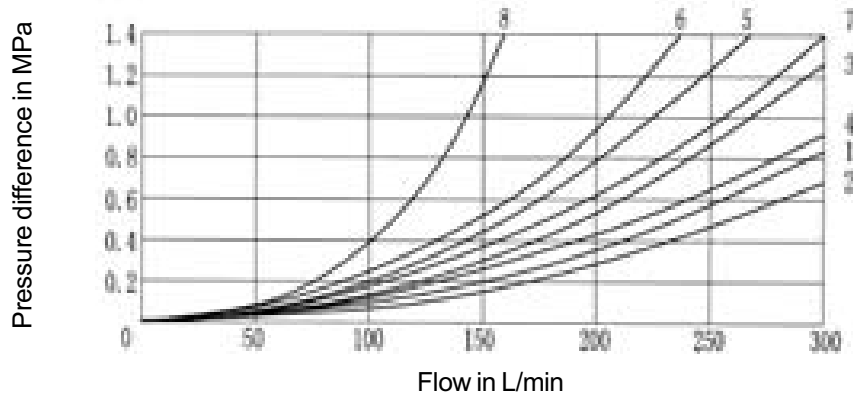

Spool	Shift position				
	P-A	P-B	A-T	B-T	P-T
E,D,Y	1	1	1	3	-
F,P	2	2	3	3	-
G,T	5	1	3	7	6
H,C,Q,V,Z	2	2	3	3	-
J,K,L	1	1	3	3	-
M,W	2	2	4	3	-
R	2	2	4	-	-
U	1	1	4	7	-
S	4	4	4	-	8

Performance limits: Type 4WEH 16...(measured at $v = 41 \text{ mm}^2/\text{s}$ and $t = 50^\circ\text{C}$)

2-position valves Permissible flow q_v in L/min					Pre-load valve, required for X = internal	
Spool	Operating pressure p_{\max} in MPa					
	7	14	21	28		35
with spring offset in the main valve ¹⁾					to approx. 160L/min	
C, D, K, Z, Y	300	300	300	300		300
with spring offset in the main valve ²⁾						
C	300	300	300	300		300
D, Y	300	270	260	250		230
K	300	250	240	230	210	
Z	300	260	190	180	160	
with hydraulic offset in the main valve					Spool HC and HZ up to approx. 160L/min	
HC, HD, HK	300	300	300	300	300	
HZ, HY	300	300	300	300	300	

3-position valves Permissible flow q_v in L/min					Pre-load valve, required for X = internal	
Spool	Operating pressure p_{\max} in MPa					
	7	14	21	28		35
spring-centred					Spools F, G, H, P and S in general	
E, H, J, L, M, QUWR	300	300	300	300		300
F, P	300	250	180	170		150
G, T	300	300	240	210		190
S	300	300	300	250		220
V	300	250	210	200	180	
pressure-centred (at min. pilot pressure of 1.6 MPa)					Spool V up to ca. 160 L/min	
for all spools	300	300	300	300	300	

- 1) The flow values given are achieved when the minimum pilot pressure of 1.2 MPa is present.
- 2) The flow values given are limiting values at which the return spring can return the valve when the pilot pressure fails.

Attention!

When using 4/3-way directional valves with spring-centring of the control spool in the main valve, which exceeds the given performance limits, a higher pilot pressure is required.

Example: At an operating pressure of $p_{\max} = 35 \text{ MPa}$ and a flow of $q_v = 300 \text{ L/min}$, a pilot pressure of 1.6 MPa is required.

The maximum flow for those valves is therefore only dependent on the Δp value which is acceptable for the system.

Characteristic curves: Type 4WEH 25...(measured at $v = 41 \text{ mm}^2/\text{s}$ and $t = 50^\circ\text{C}$)

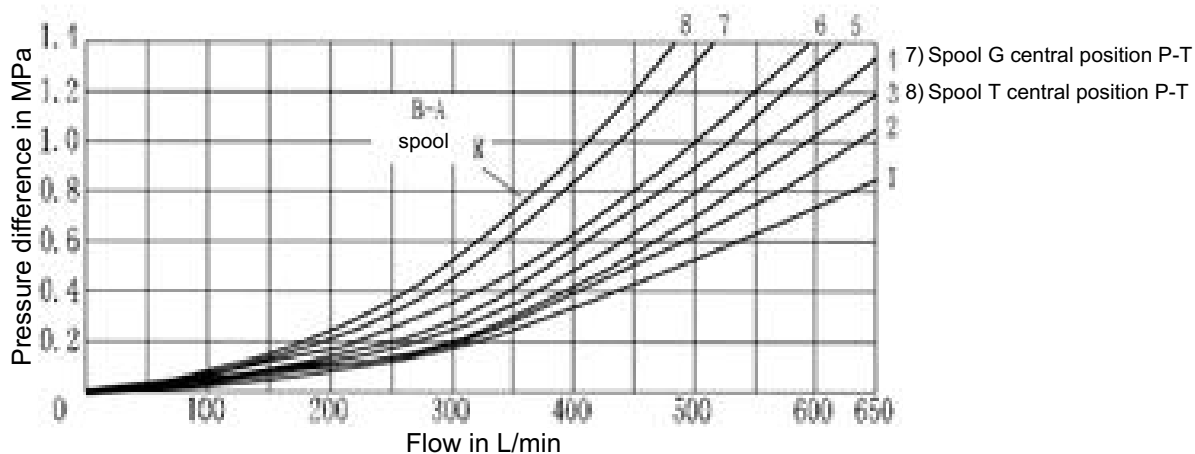

Spool	Shifted position				Spool	Neutral position			
	P-A	P-B	A-T	B-T		P-A	P-B	A-T	B-T
E	1	1	1	3	P	4	1	1	5
F	1	4	3	3	Q	2	2	3	5
G	3	1	2	4	R	2	1	1	-
H	4	4	3	4	U	2	1	1	6
J	2	2	3	5	V	4	4	3	6
L	2	2	3	3	W	1	1	1	3
M	4	4	1	4	T	3	1	2	4

Performance limits: Type 4WEH 25...(measured at $v = 41 \text{ mm}^2/\text{s}$ and $t = 50^\circ\text{C}$)

2-position valves Permissible flow q_v in L/min						Pre-load valve, required for X = internal
Spool	Operating pressure Δp in MPa					
	7	14	21	28	35	
with spring offset in the main valve ¹⁾						Spool C and Z up to approx. 180 L/min
C, D, K, Z, Y	700	700	700	700	650	
with spring offset in the main valve ²⁾						
C	700	700	700	700	700	
D, Y	700	650	400	350	300	
K	700	650	420	370	320	
Z	700	700	650	480	400	
with hydraulic offset in the main valve						Spool HC and HZ up to approx. 180 L/min
HC, HD, HK	700	700	700	700	700	
HZ, HY	700	700	700	700	700	
HC.../O	700	700	700	700	700	
HD.../O	700	700	700	700	700	
HK.../O	700	700	700	700	700	
HZ.../O	700	700	700	700	700	
HC.../OF	700	700	700	700	700	
HD.../OF	700	700	700	700	700	
HK.../OF	700	700	700	700	700	
HZ.../OF	700	700	700	700	700	

3-position valves Permissible flow q_v in L/min						Pre-load valve, required for X = internal
Spool	Operating pressure Δp in MPa					
	7	14	21	28	35	
spring-centred						Spools F, G, H, P and T in general, spool V up to approx. 180 L/min
E, L, M, Q, U, W	700	700	700	700	650	
G, T	400	400	400	400	400	
F	650	550	430	330	300	
H	700	650	550	400	360	
J	700	700	650	600	520	
P	650	550	430	330	300	
V	650	550	400	350	310	
R	700	700	700	650	580	
pressure-centred (at min. pilot pressure of 1.8MPa)						
E, F, H, J	700	700	700	700	650	
L, M, P, Q	700	700	700	700	650	
R, U, V, W	700	700	700	700	650	
G, T	700	700	700	700	400	
at > 3MPa pilot pressure						
G, T	700	700	700	700	700	

1) The flow values given are achieved when the minimum pilot pressure of 1.3 MPa is present.

2) The flow values given are limiting values at which the return spring can return the valve when the pilot pressure fails.

Characteristic curves: Type WEH 32...(measured at $v = 41 \text{ mm}^2/\text{s}$ and $t = 50^\circ\text{C}$)

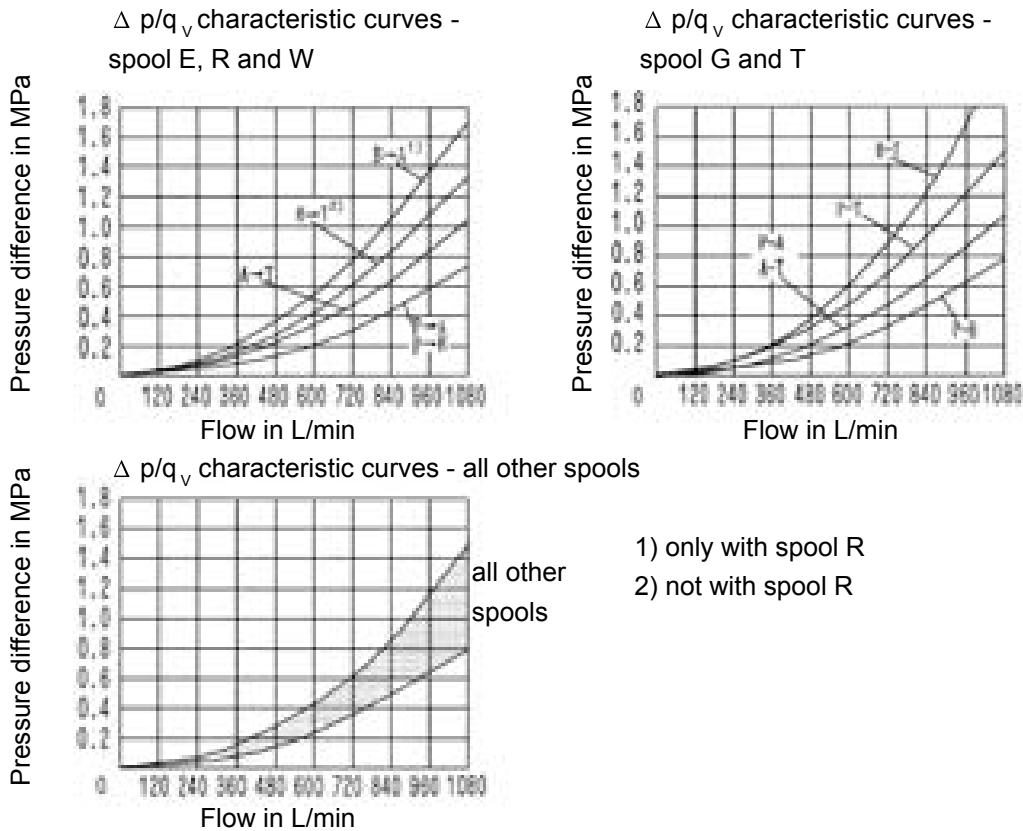

Performance limits: Type WEH 32...(measured at $v = 41 \text{ mm}^2/\text{s}$ and $t = 50^\circ\text{C}$)

2-position valves Permissible flow q_v in L/min						Pre-load valve, required for X = internal
Spool	Operating pressure p_{\max} in MPa					
	7	14	21	28	35	
with spring offset in the main valve ¹⁾						spool C in general, spool Z up to approx. 180 L/min
C, D, K, Z, Y	1100	1040	860	750	680	
with spring offset in the main valve ²⁾						
C	1100	1040	860	800	700	
D, Y	1100	1040	540	480	420	
K	1100	1040	860	500	450	
Z	1100	1040	860	700	650	
with hydraulic offset in the main valve						spool C in general, spool Z up to approx. 180 L/min
HC, HD, HK	1100	1040	860	750	680	
HZ, HY	1100	1040	860	750	680	

3-position valves Permissible flow q_v in L/min						Pre-load valve, required for X = internal
Spool	Operating pressure p_{\max} in MPa					
	7	14	21	28	35	
spring-centred ¹⁾						Spools F, G, H, P and T in general, spool V up to 180 L/min
E, J, L, M, Q, U, W, R	1100	1040	860	750	680	
G, T, H, F, P	900	900	800	650	450	
V	1100	1000	680	500	450	
pressure-centred (at min. pilot pressure of 0.85MPa)						
for all spools						
1100 1040 860 750 680						

Attention!

When using 4/3-way directional valves with spring-centring of the control spool in the main valve, which exceeds the given performance limits, a higher pilot pressure is required.

Example: At an operating pressure of $p_{\max} = 35 \text{ MPa}$ and a flow of $q_v = 1100 \text{ L/min}$, a pilot pressure of 1.5 MPa is required.

The maximum flow for those valves is therefore only dependent on the Δp value which is acceptable for the system.

- 1) The flow values given are achieved when the minimum pilot pressure of 1MPa is present.
- 2) The flow values given are limiting values at which the return spring can return the valve when the pilot pressure Spools.

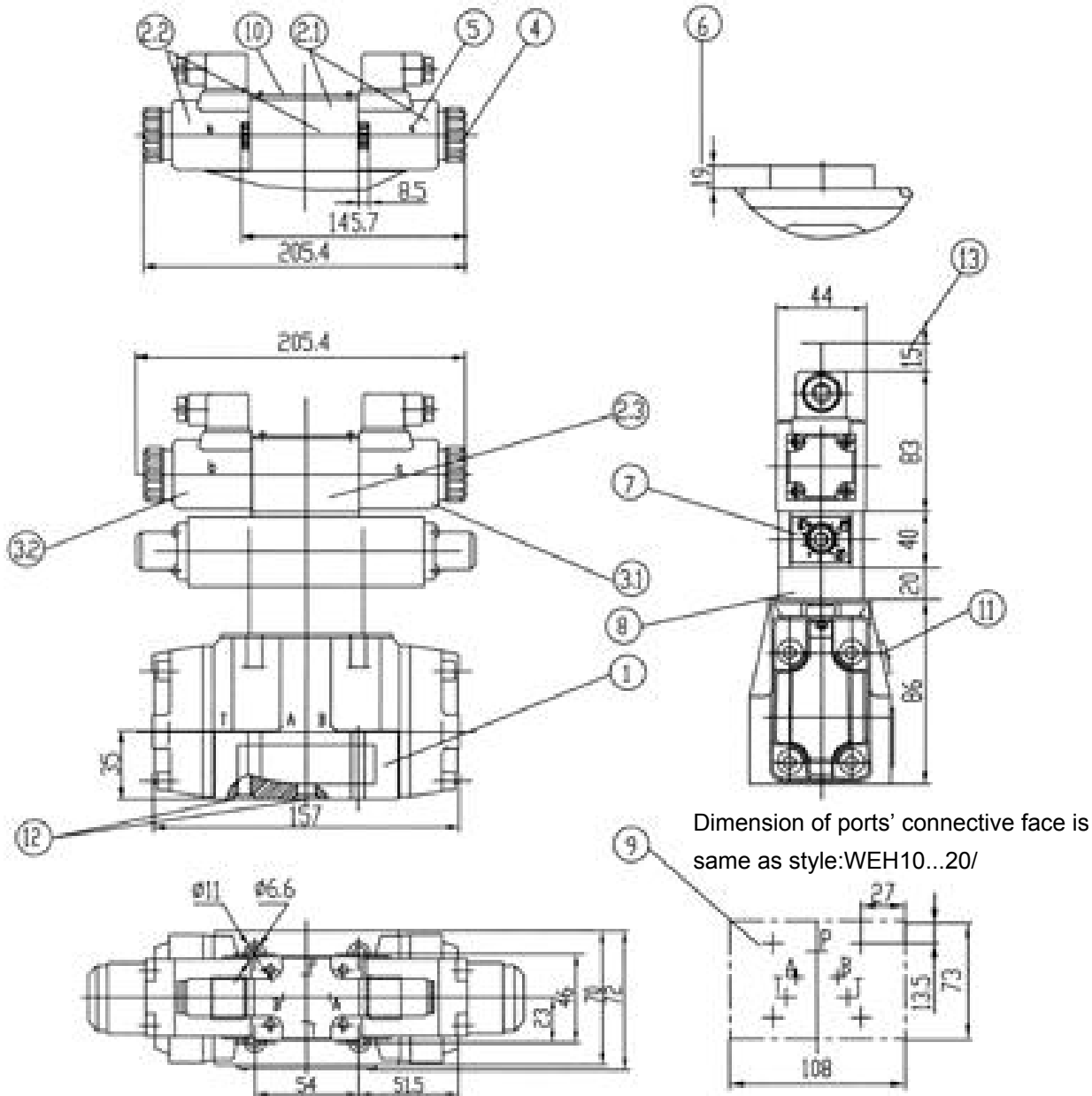

Subplate

G 534/01 (G 3/4"), — without port X, Y

G 535/01 (G 3/4"), > with port X, Y

G 536/01 (G 1")

Valve fixing screws 4- M6 × 45 -10.9

(GB/T70.1-2000)

$M_A = 15.5 \text{ Nm}$

must be ordered separately.

For items list, see page 206,207.

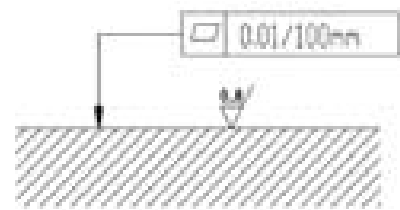

Required surface finish of the mating piece

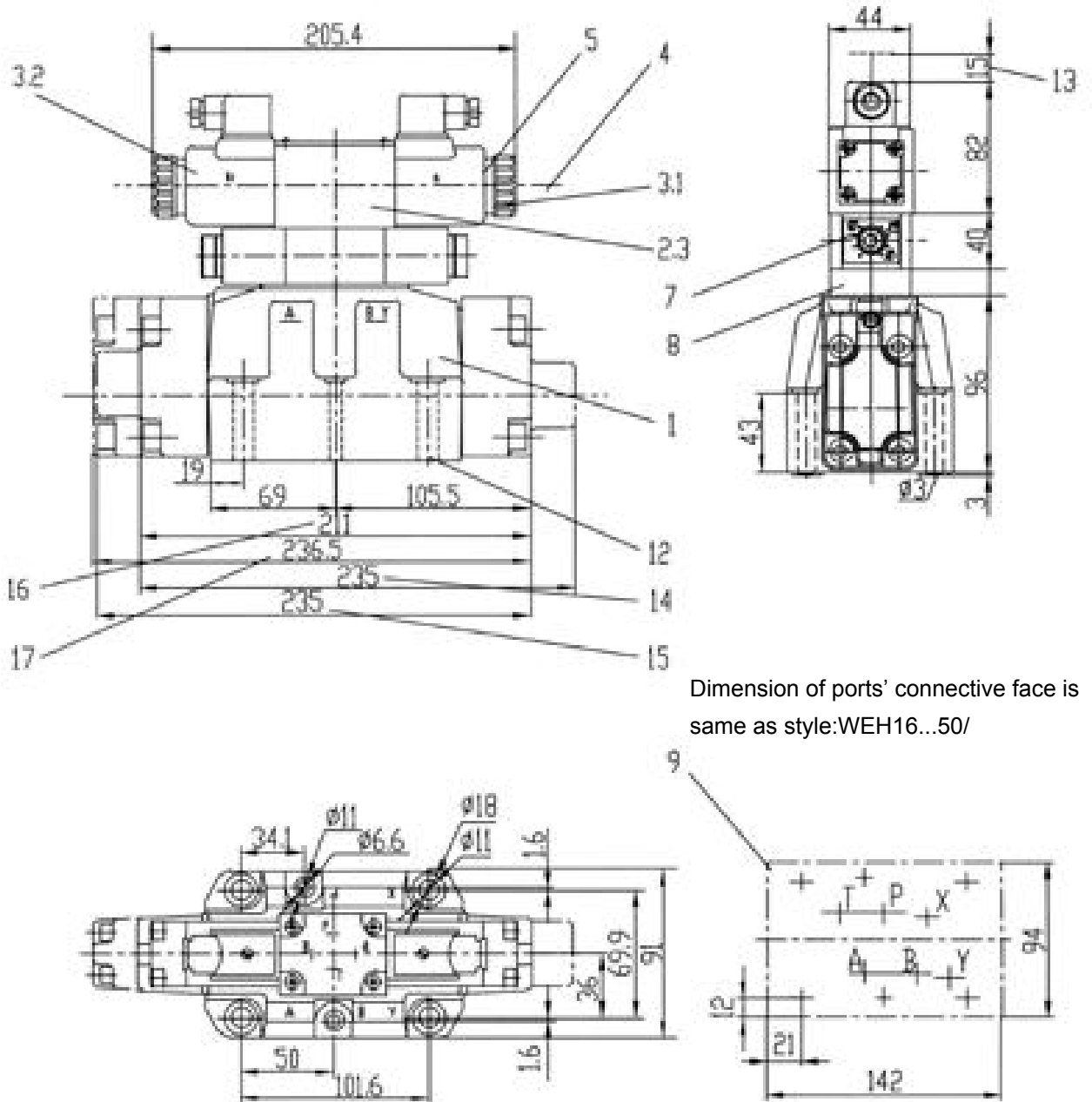

Dimension of ports' connective face is same as style:WEH16...50/

Subplates

G 172/01 (G 3/4"), G 172/02 (M27 x 2),
 G 174/01 (G 1"), G 174/02 (M33 x 2), G 174/08 (flange)

Valve fixing screws

4 - M10 x 60-10.9 (GB/T70.1-2000)

$M_A = 75 \text{ Nm}$

2 - M6 x 60-10.9 (GB/T70.1-2000)

$M_A = 15.5 \text{ Nm}$

must be ordered separately.

For items list, see page 207,208.

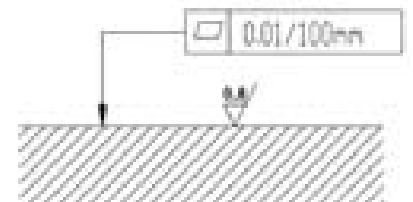

Required surface finish of the mating piece

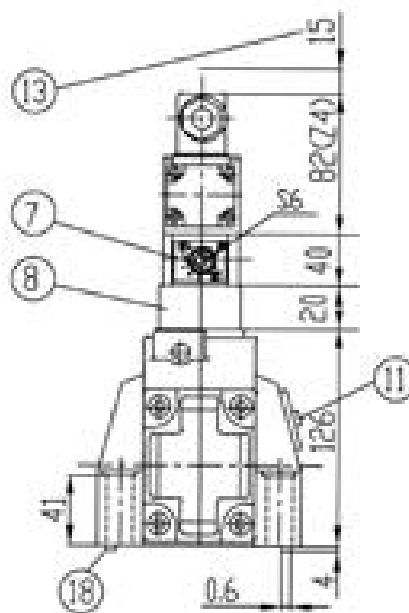
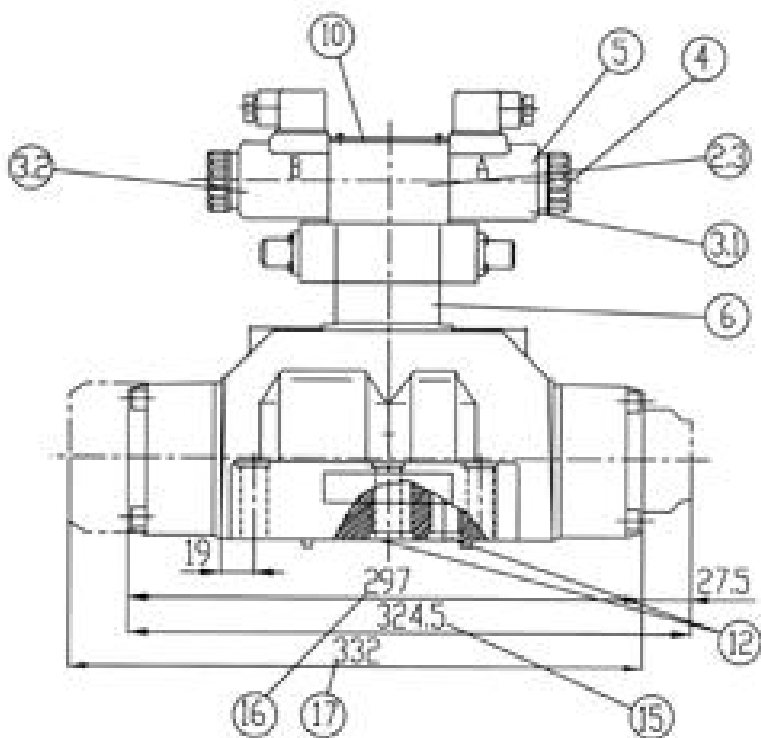

dimension of ports connective flate is the same as style:WEH25...50/

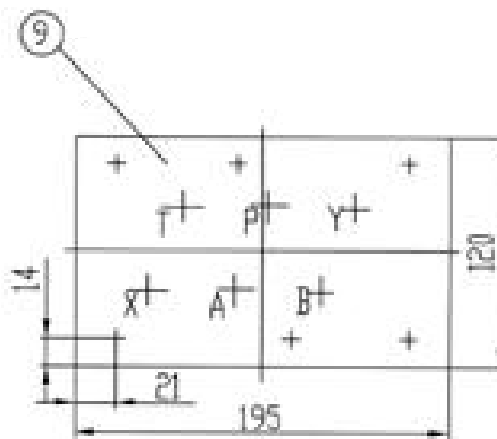
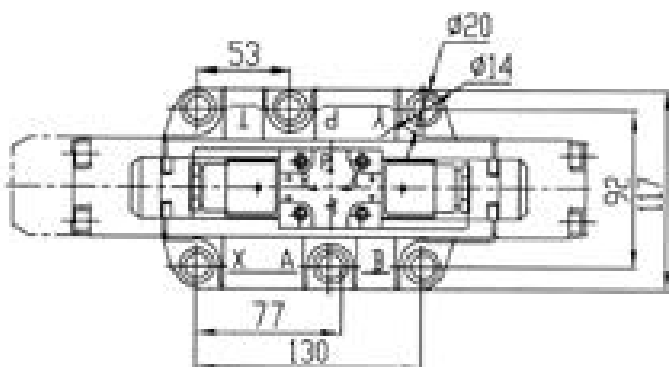

Subplates

G 151/01 (G 1"),

G 153/01 (G 1"), for valves with pressure-centred neutral position

G 154/01 (G 1 1/4"), G 154/08 (flange)

G 156/01 (G 1 1/2")

Valve fixing screws

6 - M12 x 60 -10.9 (GB/T70.1-2000)

$M_A = 130 \text{ Nm}$

must be ordered separately.

For items list, see page 209,210.

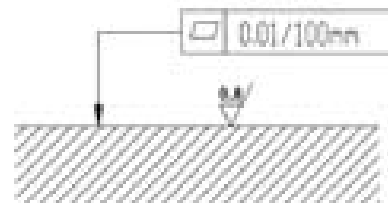

Required surface finish of the mating piece

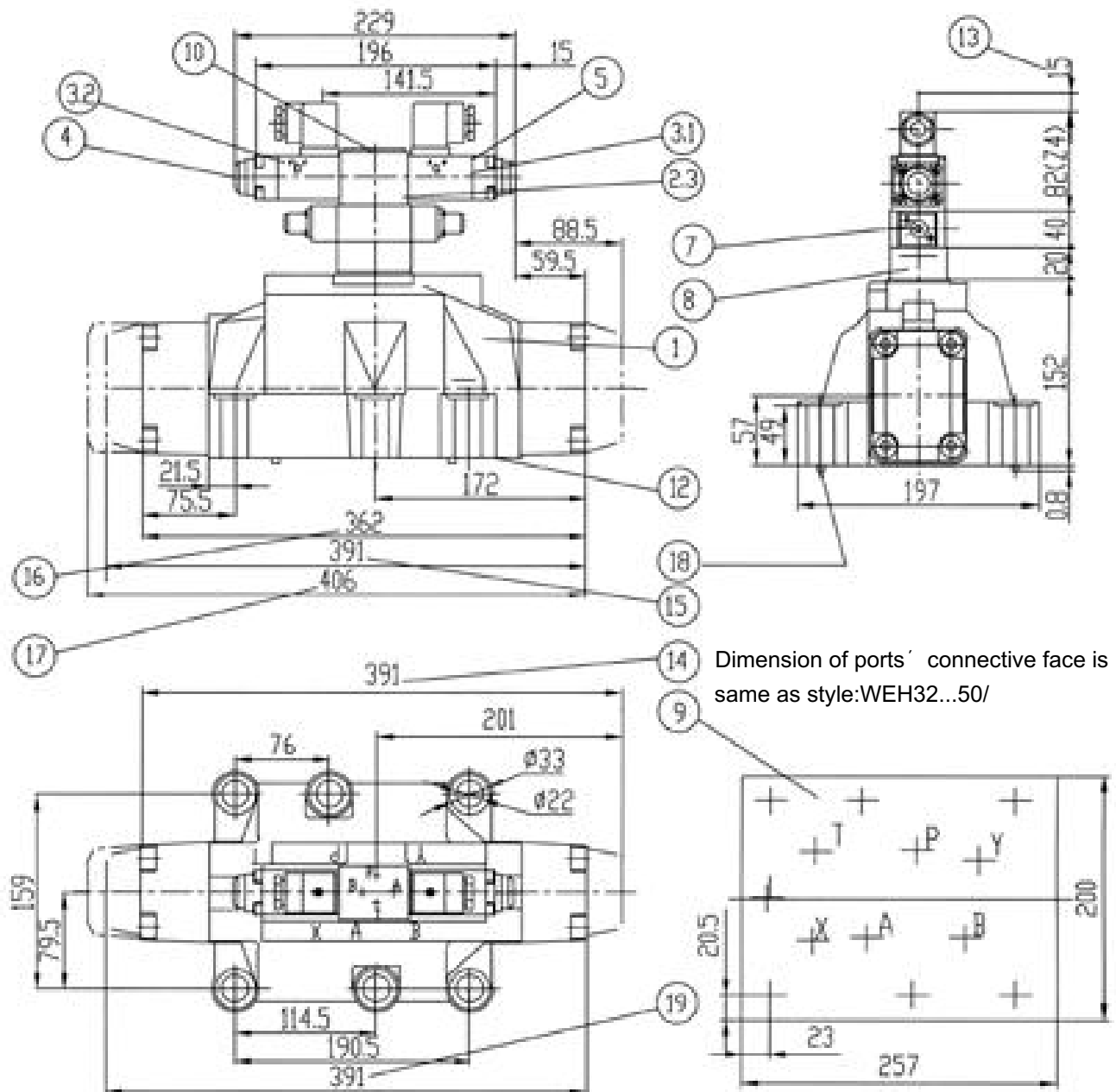

Dimension of ports' connective face is same as style:WEH32...50/

Subplates

G 157/01 (G 1 1/2"),

G 157/02 (M48 x 2),

G 158/10 (flange)

Valve fixing screws

6 - M20 x 80-10.9 (GB/T70.1-2000)

$M_A = 430 \text{ Nm}$

must be ordered separately.

For items list, see page 210,211

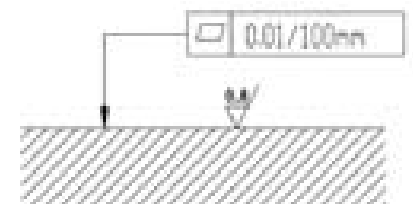

Required surface finish of the mating piece

List of items:

- | | |
|---|--|
| <p>1 Main valve</p> <p>2 Pilot valve type 4WE 6 ...</p> <p>2.1 · Pilot valve type 4WE 6 D(1 solenoid) for main valves with spools C, D, K, Z
spools HC, HD, HK, HZ</p> <p>· Pilot valve type 4WE 6 J...(1 solenoid "a") for main valves with spools EA, FA, etc., spring return</p> <p>· Pilot valve type 4WE 6 M...(1 solenoid "a") for main valves with spools HEA, HFA, etc., hydraulic spool return</p> <p>2.2 · Pilot valve type 4WE 6 Y...(1 solenoid) for main valves with spool Y spool HY</p> <p>· Pilot valve type 4WE 6 J...(1 solenoid "b") for main valves with spools EB, FB, etc.,spring return</p> <p>· Pilot valve type 4WE 6 M...(1 solenoid "b") for main valves with spools HEB, HFB, etc., hydraulic spool return</p> <p>2.3 · Pilot valve type 4WE 6 J...(2 solenoids) for main valves with 3 positions, spring-centred</p> <p>· Pilot valve type 4WE 6 M...(2 solenoids) for main valves with 3 positions, pressure-centred</p> <p>3.1 Solenoid "a" (grey plug-in connector)</p> <p>3.2 Solenoid "b" (black plug-in connector)</p> <p>4 Manual override "N", optional</p> <p>- The manual override can only be operated up to a tank pressure of up to approx. 5MPa.
Take care not to damage the manual override bore!</p> <p>5 Solenoid without manual override</p> <p>6 Height of the connector plate for hydraulic operation (type 4WH...)</p> <p>7 Shifting time adjustment (A/F 6), optional</p> <p>8 Pressure reducing valve, optional</p> | <p>9 Machined valve mounting surface, position of ports</p> <p>10 Nameplate for the pilot valve</p> <p>11 Nameplate for the entire valve</p> <p>12 O-rings</p> <p>13 Space required to remove the plug-in connector</p> <p>14 2-position valves with spring offset in the main valve (C, D, K, Z)</p> <p>15 2-position valves with spring offset in the main valve (Y)</p> <p>16 3-position valves, spring-centred;
2-position valves with hydraulic offset in the main valve</p> <p>17 3-position valves, pressure-centred</p> <p>18 Locating pin</p> |
|---|--|

O-Ring used at the bottom of the housing:

Order no.	A, B, P, T	X, Y, L
10	12 × 2	10.82 × 1.78
16	22 × 2.5	10 × 2
25	27 × 3	19 × 3
32	42 × 2	12 × 2

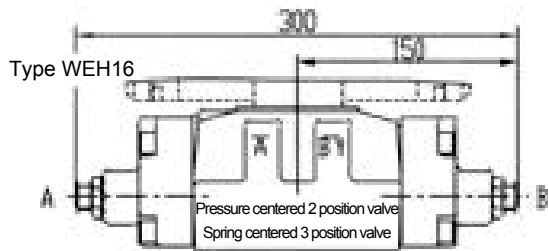

Stroke limiter on main valve sides A and B Stroke limiter on valve side A
Stroke limiter on valve side B

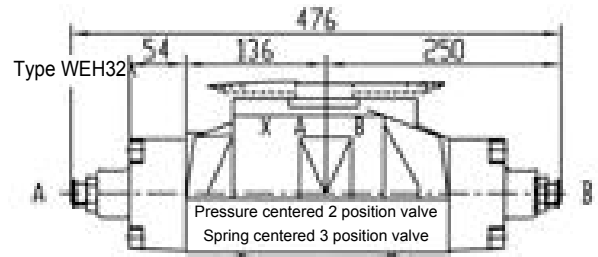

Stroke limiter on main valve sides A and B Stroke limiter on valve side A
Stroke limiter on valve side B

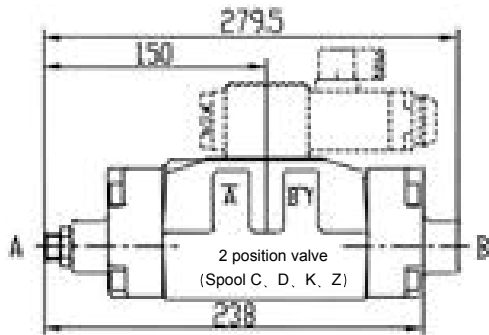

Stroke limiter on valve side A 11

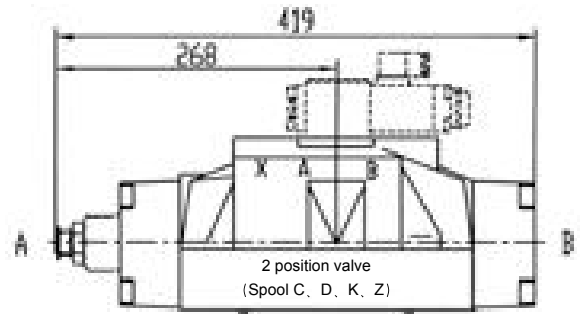

Stroke limiter on valve side A 11

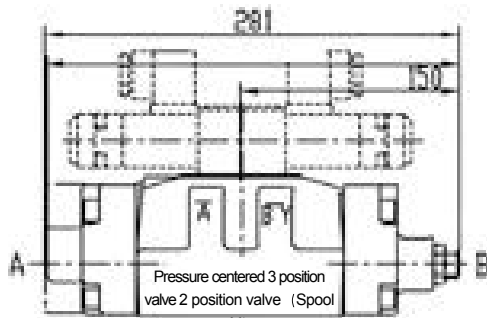

Stroke limiter on valve side B 12

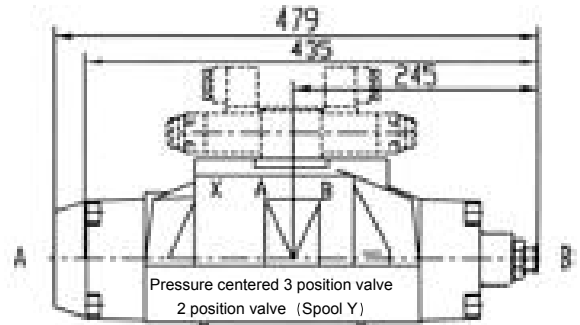

Stroke limiter on valve side B 12

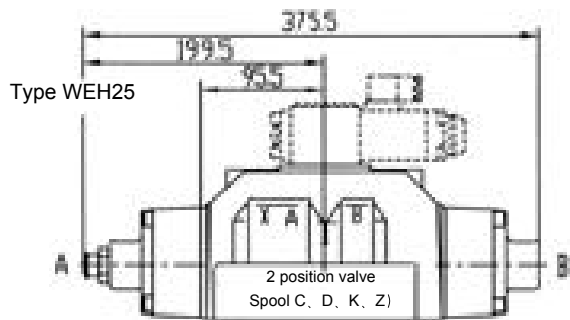

Stroke limiter on valve side A 11

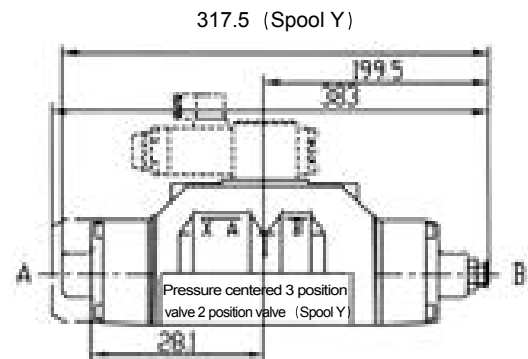

Stroke limiter on valve side B

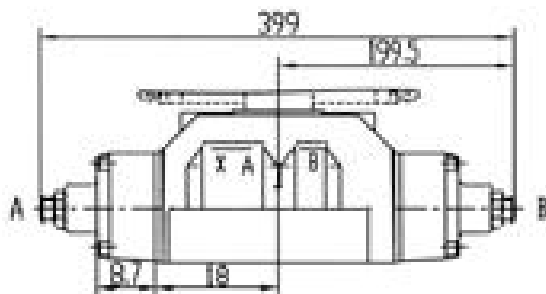

Stroke limiter on main valve sides A and B Stroke limiter on valve side A
Stroke limiter on valve side B

Notice

1. The fluid must be filtered. Minimum filter fineness is 20 μm .
2. The tank must be sealing up and an air filter must be installed on air entrance.
3. Products without subplate when leaving factory, if need them, please ordering specially.
4. Valve fixing screws must be high intensity level (class 10.9). Please select and use them according to the parameter listed in the sample book.
5. Roughness of surface linked with the valve is required to $\frac{0.8}{\sqrt{\text{mm}}}$.
6. Surface finish of mating piece is required to 0.01/100mm.