

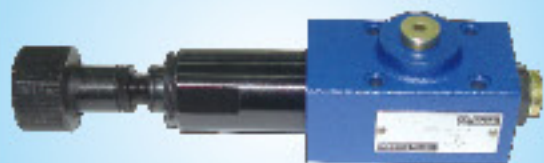

Huade



Hydraulic valves



Pressure Valves

Catalogue



BEIJING HUADE HYDRAULIC INDUSTRIAL GROUP CO.,LTD.

CONTENTS

Pressure Valves

No.	Name	Type	Size	Pressure max.(MPa)	Page
1	Pressure remote relief valve	DBT/DBWT		31.5	1
2	Pressure relief valve , direct operated	DBD	6~30	63	5
3	Direct operated pressure relief valve,sandwich plate	Z2DBD6	6	31.5	11
4	*Pilot operated pressure relief Valve,sandwich plate	ZDB/Z2DB	6	31.5	15
5	Pilot operated pressure relief valve,sandwich plate	ZDB/Z2DB	10	31.5	21
6	Pilot operated pressure relief valve,cartridge connection	DB...K	6、10、20	31.5	27
7	Pressure relief valve	DB/DBW...30B/...	10~30	31.5	37
	Pressure relief valve(New series)	DB/DBW...50B/ ...	10~32	35	43
8	Pressure relief valves	DB3U	10~30	31.5	53
9	*Check-Q-meter	DC	10~30	31.5	61
10	Pressure reducing valve direct operated,sandwich plate	ZDR6D...30B	6	21	67
	*Pressure reducing valve direct operated,sandwich plate (New series)	ZDR6D...40B	6	21	71
11	*Pressure reducing valve	ZDR6DP0...40B/40YM	6	4.0	75
12	Direct operated pressure reducing valve,sandwich plate	ZDR10D...40B/	10	21	79
13	*Direct operated pressure reducing valve,sandwich plate(New series)	ZDR10D-50B/	10	21	83
14	*Pressure reducing valve direct operated	DR5DP	5	31.5	87
	*Pressure reducing valve direct operated	DR6DP	6	21	91
	*Pressure reducing valve direct operated	DR10DP	10	21	95



CONTENTS

Pressure Valves

No.	Name	Type	Size	Pressure max.(MPa)	Page
15	Pilot operated pressure reducing Valve	DR...30B/...	10、20、30	31.5	99
	*Pilot operated pressure reducing Valve (New series)	DR...50B/	10~25	31.5	105
16	*Direct operated pressure sequence Valve	DZ5DP	5	31.5	111
	*Direct operated pressure sequence valve	DZ6DP	6	31.5	115
	*Direct operated pressure sequence valve	DZ10DP	10	21	119
17	Pressure sequence valve pilot operated	DZ...30B/	10~30	21	123
	*Pressure sequence valve pilot operated (New series)	DZ...-50B/	10、20、30	31.5	129
18	Pressure shut-off valve pilot operated	DA/DAW...-30B/	10、20、30	31.5	135
	*Pressure shut-off valve pilot operated (New series)	DA/DAW...-50B/	10、20、30	31.5	141
19	Subplate	—	—	—	148

* * : New products, for ordering, please consult us, telephone:+86-10-69083290



Other Huade Hydraulics Catalogues for Valves

- Directional Valves
- Flow Control Valves
- Proportional Valves
- Cartridge Valves

BEIJING HUADE HYDRAULIC INDUSTRIAL GROUP CO.,LTD.	Pilot operated pressure relief valve sandwich plate,type ZDB/Z2DB6			RE25750/12.2004
	Size 6	up to 31.5 MPa	up to 60 L/min	Replaces: RE25750/05.2001

Features:

- Sandwich plate valve
- 4 pressure ranges
- 5 circuit options
- With one or two pressure relief cartridges
- 4 adjustment elements:
 - Rotary knob
 - Sleeve with hexagon and protective cap
 - Lockable rotary knob with scale
 - Lockable rotary knob



Functional, section

Pressure relief valve types ZDB and Z2DB are pilot operated and are of sandwich plate design. They are used to limit the pressure within a hydraulic system.

They basically consist of the housing (7), together with one or two pressure relief valve cartridges.

The system pressure is set by means of adjustment element (4).

At rest, the valve is closed. Pressure in port A acts on the spool (1). At the same time pressure passes through orifice (2) on to the spring loaded side of spool (1) and via orifice (3) to the pilot poppet (6). If the pressure in port A rises above the value set on spring (5), the pilot poppet (6) opens. Fluid can now flow from the spring loaded side of spool (1), orifice (3), and channel (8) into port T. The resulting pressure drop then moves spool (1), causing this to open connection A to T, while the pressure set at spring (5) is maintained.

Pilot oil from the two spring chambers return externally to tank via port T.

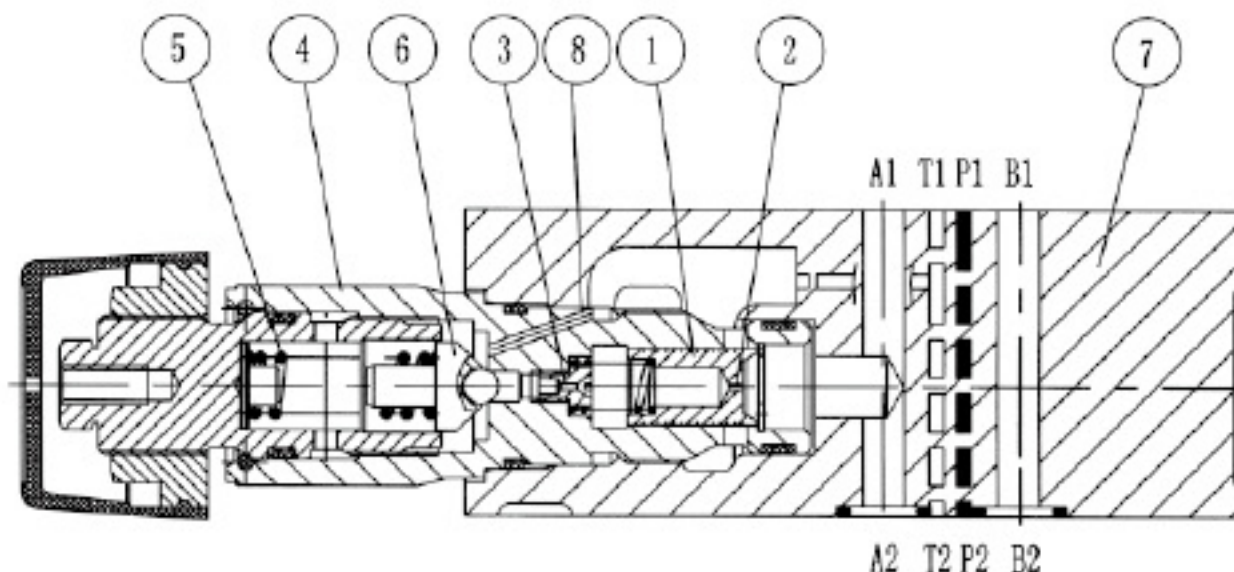

Type ZDB 6 VA2 - 40B/..

Ordering code

Z DB 6 - 40 B *

Sandwich plate = Z

Further details in clear text

Only applies to models VC and VD:

With 1 pressure relief valve cartridges = no code

With 2 pressure relief valve cartridges = 2

No code = mineral oils

V = phosphate ester

Pressure relief valve = DB

50 = Pressure adjustable up to 5 MPa

100 = Pressure adjustable up to 10 MPa

200 = Pressure adjustable up to 20 MPa

315 = Pressure adjustable up to 31.5 MPa

Nominal size 6 = 6

B= Technology of Beijing Huade Hydraulic

40= Series 40 to 49
(40 to 49 = unchanged installation and connection dimensions)

Relief function form:

A → T = VA

P → T = VP

B → T = VB

A → T and B → T = VC

A → B and B → A = VD

Adjustment element

1 = Rotary knob

2 = Sleeve with hexagon and protective cap

3 = Lockable rotary knob with scale

7 = Rotary knob with scale

Symbols: 1-valve side, 2-subplate side

ZDB 6 VA ..

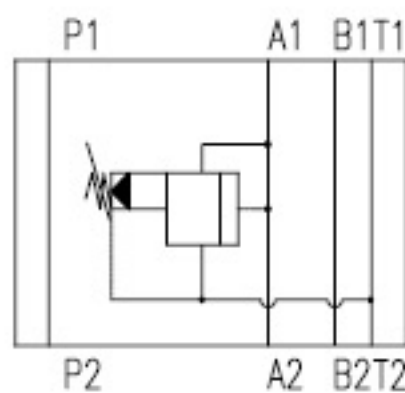

ZDB 6 VB ..

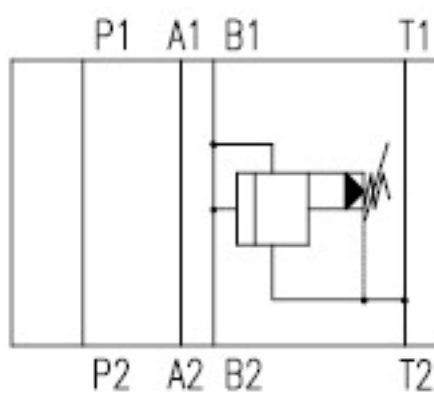

ZDB 6 VP ..

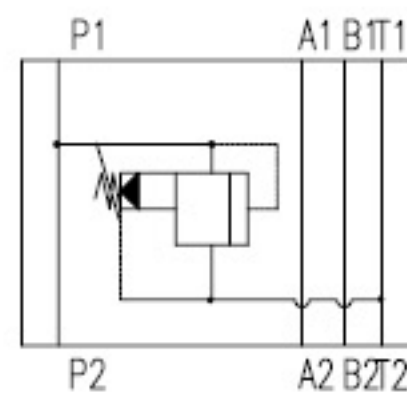

Z2DB 6 VC ..

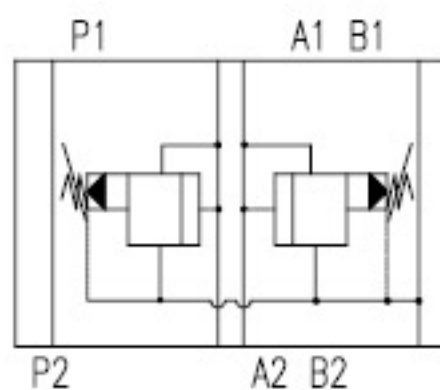

Z2DB 6 VD ..

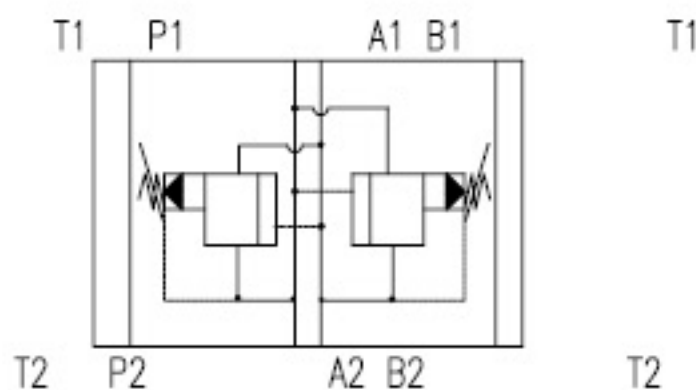

Technical data (For applications outside these parameters, please consult us!)

Pressure fluid	Mineral oil (for NBR seal), or phosphate ester (for FPM seal)		
Pressure fluid - temperature range (°C)	-30 ~ +80		
Viscosity range (mm ² /s)	10 ~ 800		
Degree of fluid contamination	Maximum permissible degree of contamination of the fluid is to NAS 1638, class 9. $\beta_{10} \geq 75$		
Operating pressure, max. (MPa)	up to 31.5		
Pressure adjustable, max. setting (MPa)	up to 5, to 10, to 20, to 31.5		
Flow, max. (L/min)	up to 60		
Weight	Type ZDB 6 (Kg)	approx. 1	
	Type Z2DB 6 (Kg)	approx. 1.2	

Characteristic curves (measured at $v = 41 \text{ mm}^2/\text{s}$ and $t = 50^\circ\text{C}$)

P_E - Q characteristic curve

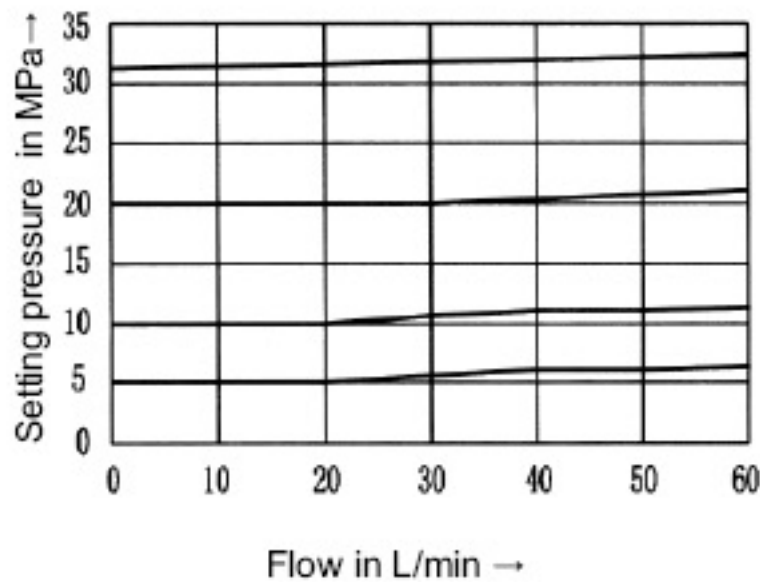

P_{Emin} - Q characteristic

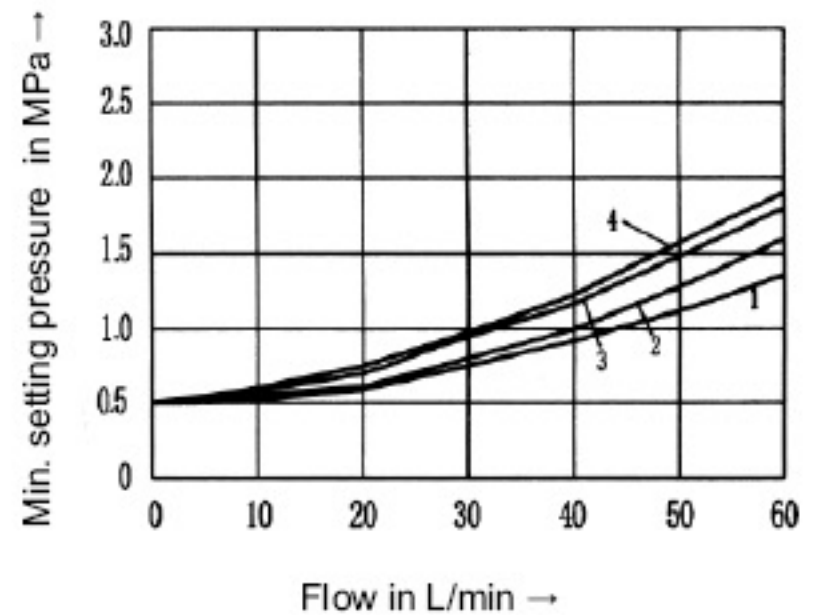

- | | |
|---------------|--------------------|
| 1 VD (A to B) | 3 VB , VC |
| 2 VA | 4 VP , VD (B to A) |

Type ZDB6 VA..

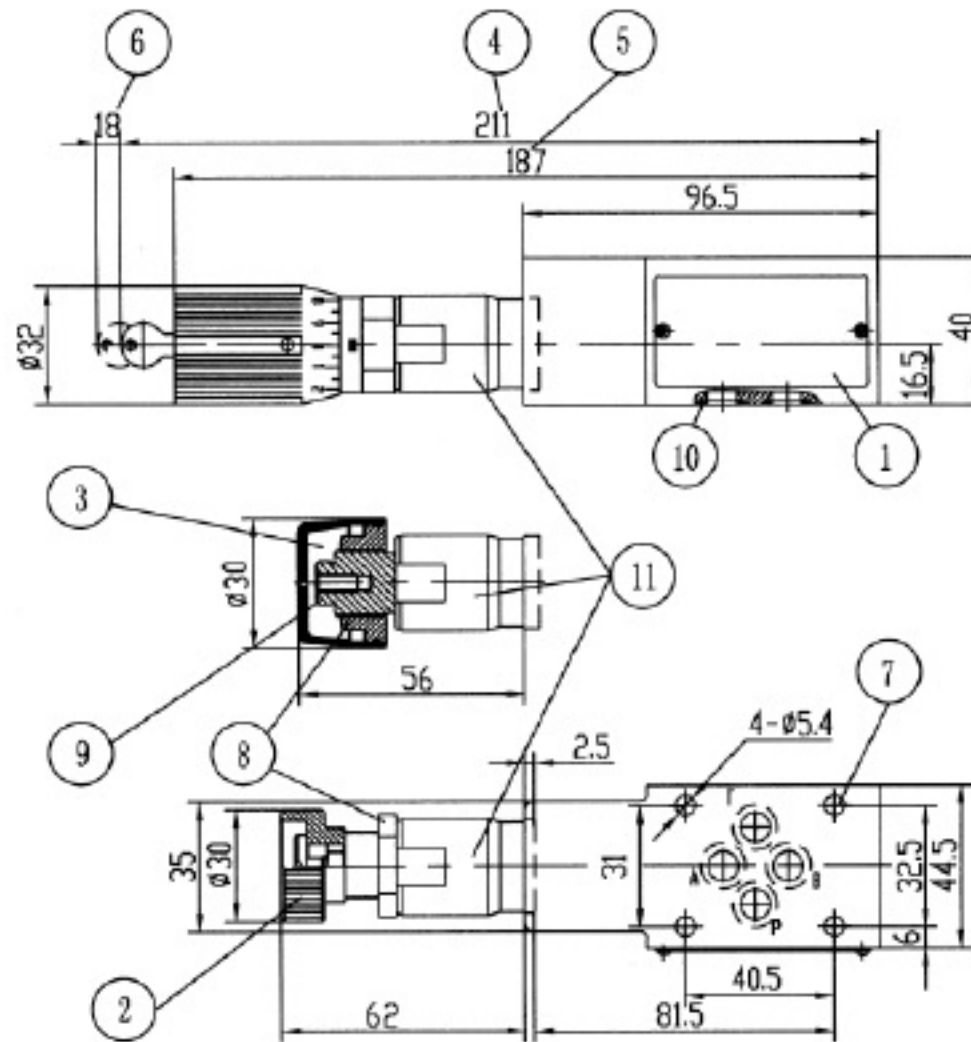

Type ZDB6 VB.. and ZDB6 VP..

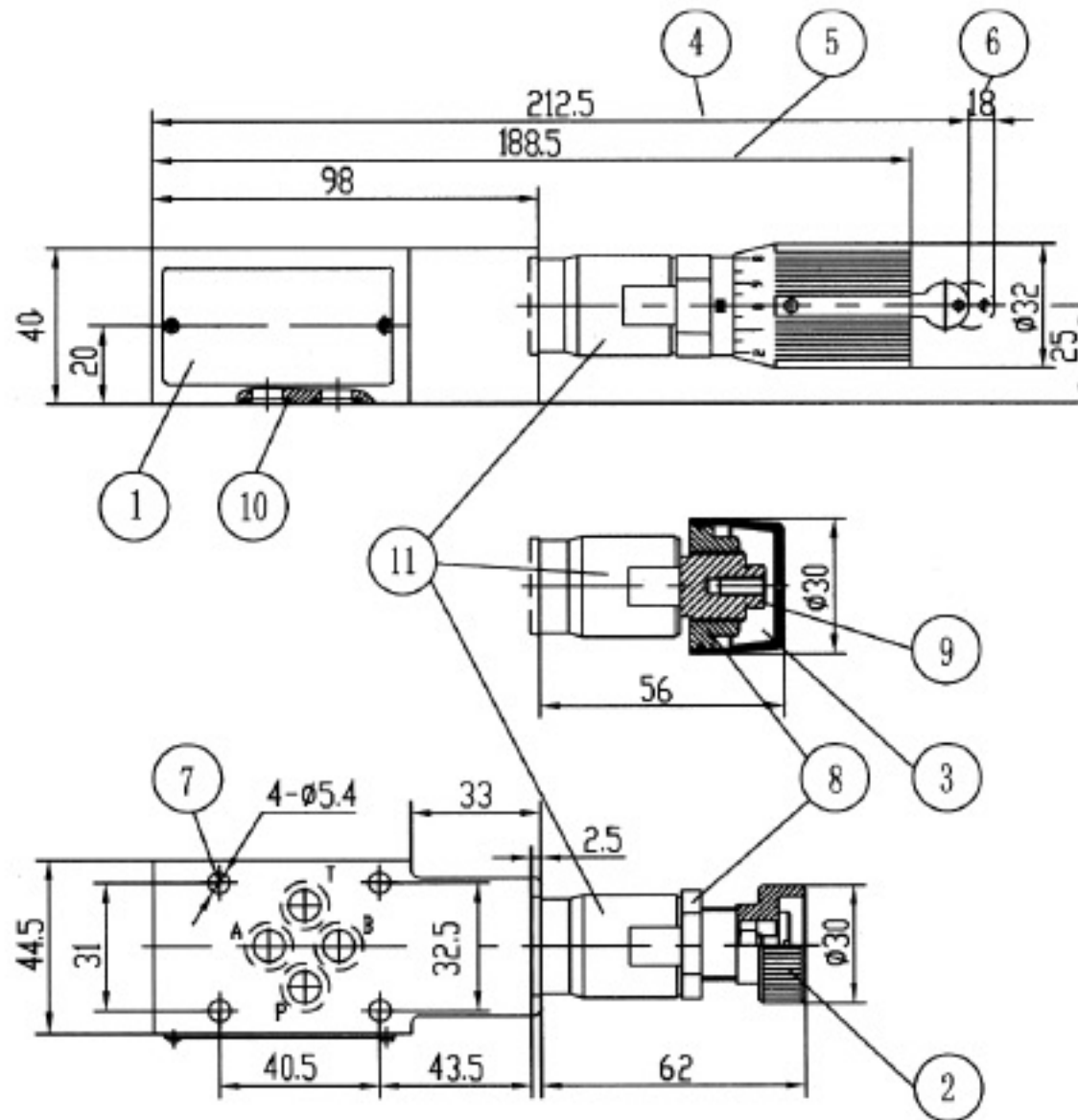

Type Z2DB6 VC..and Z2DB6 VD..

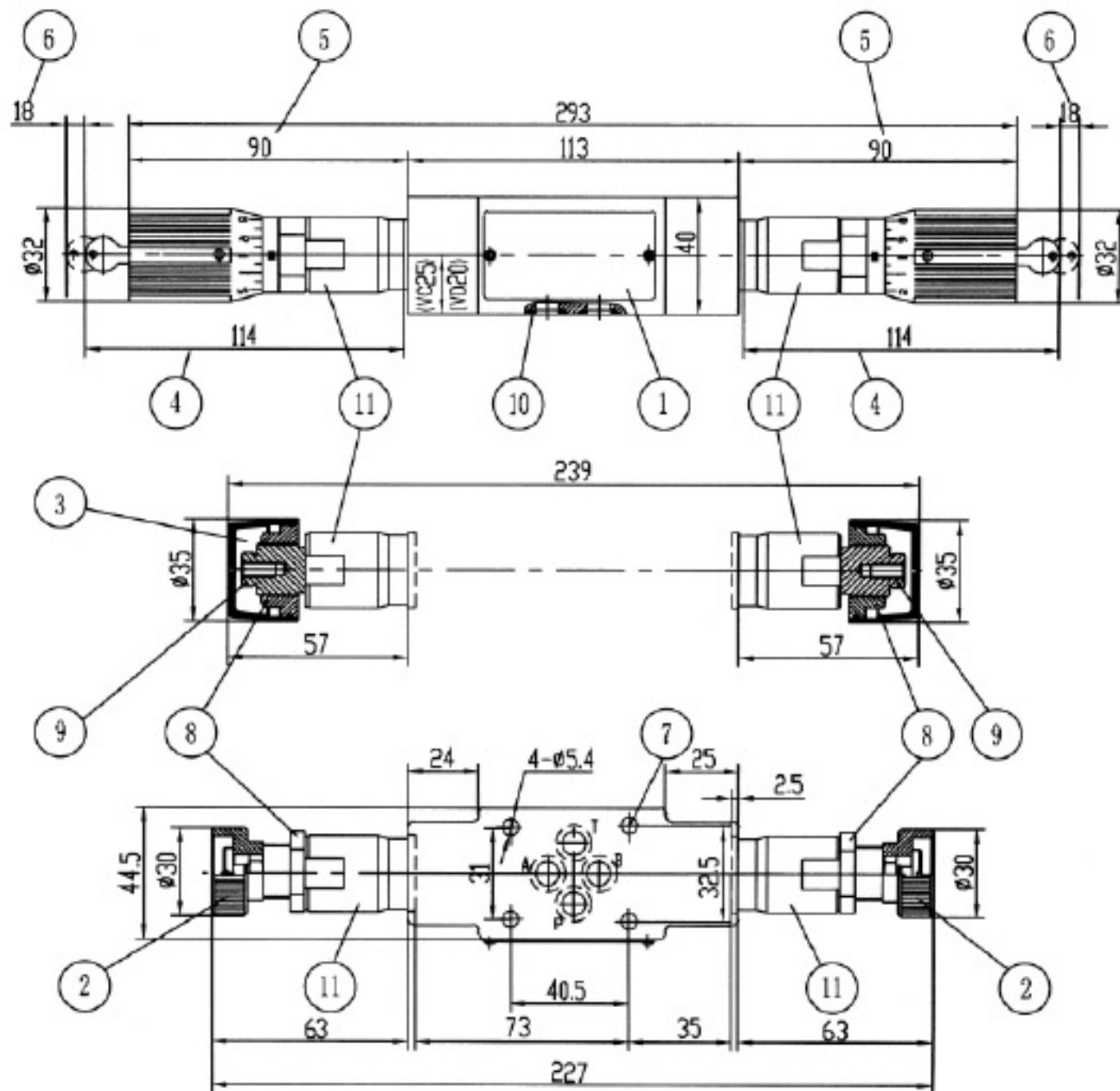

- 1 Nameplate
 - 2 Adjustment element 1
 - 3 Adjustment element 2
 - 4 Adjustment element 3
 - 5 Adjustment element 7
 - 6 Space required to remove key
 - 7 Valve fixing screw holes
 - 8 Lock nut 24 A/F
 - 9 Hexagon 10 A/F
 - 10 O-ring 9.25 x 1.78 for ports A2, B2, P2, T2
 - 11 Hexagon 24 A/F
- Tightening torque $M_A = 50 \text{ Nm}$

Required surface finish of mating piece

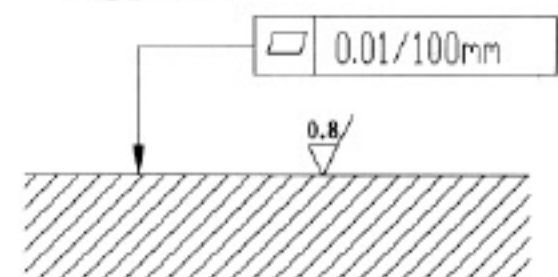

NOTICE

1. The fluid must be filtered. Minimum filter fineness is 20 μm .
2. The tank must be sealing up and an air filter must be installed on air entrance.
3. Products without subplate when leaving factory, if need them, please ordering specially.
4. Valve fixing screws must be high intensity level (class 10.9). Please select and use them according to the parameter listed in the sample book.
5. Roughness of surface linked with the valve is required to $\frac{0.8}{\nabla}$.
6. Surface finish of mating piece is required to 0.01/100mm.

Notice

1. The fluid must be filtered. Minimum filter fineness is 20 μm .
2. The tank must be sealing up and an air filter must be installed on air entrance.
3. Products without subplate when leaving factory, if need them, please ordering specially.
4. Valve fixing screws must be high intensity level (class 10.9). Please select and use them according to the parameter listed in the sample book.
5. Roughness of surface linked with the valve is required to $\frac{0.8}{\sqrt{\text{ }}$.
6. Surface finish of mating piece is required to 0.01/100mm.

CONTENTS

Pressure Valves

No.	Name	Type	Size	Pressure max.(MPa)	Page
1	Pressure remote relief valve	DBT/DBWT		31.5	1
2	Pressure relief valve , direct operated	DBD	6~30	63	5
3	Direct operated pressure relief valve,sandwich plate	Z2DBD6	6	31.5	11
4	*Pilot operated pressure relief Valve,sandwich plate	ZDB/Z2DB	6	31.5	15
5	Pilot operated pressure relief valve,sandwich plate	ZDB/Z2DB	10	31.5	21
6	Pilot operated pressure relief valve,cartridge connection	DB...K	6、10、20	31.5	27
7	Pressure relief valve	DB/DBW...30B/...	10~30	31.5	37
	Pressure relief valve(New series)	DB/DBW...50B/ ...	10~32	35	43
8	Pressure relief valves	DB3U	10~30	31.5	53
9	*Check-Q-meter	DC	10~30	31.5	61
10	Pressure reducing valve direct operated,sandwich plate	ZDR6D...30B	6	21	67
	*Pressure reducing valve direct operated,sandwich plate (New series)	ZDR6D...40B	6	21	71
11	*Pressure reducing valve	ZDR6DP0...40B/40YM	6	4.0	75
12	Direct operated pressure reducing valve,sandwich plate	ZDR10D...40B/	10	21	79
13	*Direct operated pressure reducing valve,sandwich plate(New series)	ZDR10D-50B/	10	21	83
14	*Pressure reducing valve direct operated	DR5DP	5	31.5	87
	*Pressure reducing valve direct operated	DR6DP	6	21	91
	*Pressure reducing valve direct operated	DR10DP	10	21	95



CONTENTS

Pressure Valves

No.	Name	Type	Size	Pressure max.(MPa)	Page
15	Pilot operated pressure reducing Valve	DR...30B/...	10、20、30	31.5	99
	*Pilot operated pressure reducing Valve (New series)	DR...50B/	10~25	31.5	105
16	*Direct operated pressure sequence Valve	DZ5DP	5	31.5	111
	*Direct operated pressure sequence valve	DZ6DP	6	31.5	115
	*Direct operated pressure sequence valve	DZ10DP	10	21	119
17	Pressure sequence valve pilot operated	DZ...30B/	10~30	21	123
	*Pressure sequence valve pilot operated (New series)	DZ...-50B/	10、20、30	31.5	129
18	Pressure shut-off valve pilot operated	DA/DAW...-30B/	10、20、30	31.5	135
	*Pressure shut-off valve pilot operated (New series)	DA/DAW...-50B/	10、20、30	31.5	141
19	Subplate	—	—	—	148

* * : New products, for ordering, please consult us, telephone:+86-10-69083290



Other Huade Hydraulics Catalogues for Valves

- Directional Valves
- Flow Control Valves
- Proportional Valves
- Cartridge Valves

BEIJING HUADE HYADRAULIC INDUSTRIAL GROUP CO.,LTD.	Pilot operated pressure relief valve, sandwich plate,type ZDB/Z2DB10			RE 25761/12.2004
	Size10	up to 31.5 MPa	up to 100 L/min	Replaces: RE25750/05.2001

Features:

- Sandwich plate valve
- 4 pressure ranges
- 5 circuit options
- With one or two pressure relief cartridges
- 4 adjustment elements:
 - Rotary knob
 - Sleeve with hexagon and protective cap
 - Lockable rotary knob with scale
 - Lockable rotary knob



Functional, section

Pressure relief valve types ZDB and Z2DB are pilot operated and are of sandwich plate design. They are used to limit the pressure within a hydraulic system, together with one or two pressure relief valve cartridges. The system pressure is set by means of adjustment element (4).

At rest, the valve is closed. Pressure in port A acts on the spool (1). At the same time pressure passes through orifice (2) on to the spring loaded side of spool (1) and via orifice (3) to the pilot poppet (6). If the pressure in port A rises above the value set on spring (5), the pilot poppet (6) opens. Fluid can now flow from the spring loaded side of spool (1), orifice (3), and channel (8) into port T. The resulting pressure drop then moves spool (1), causing this to open connection A to T, while the pressure set at spring (5) is maintained.

Pilot oil return from the two spring chambers is taken externally via port T.

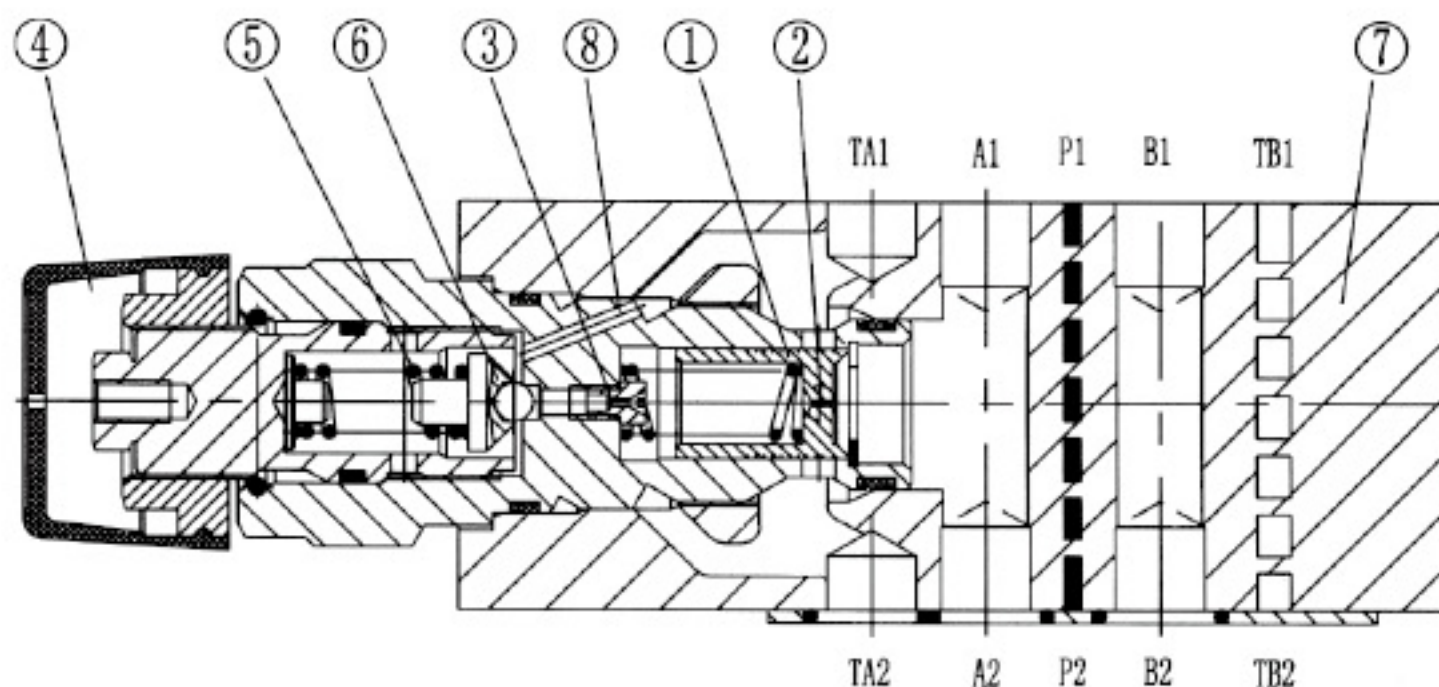

Type ZDB 6 VA2 - 40B/..

Ordering code

Z DB 10 - - B / *

Sandwich plate = Z

Only applies to models VC and VD:
 With 1 pressure relief valve cartridges = No code
 With 2 pressure relief valve cartridges = 2

Pressure relief valve = DB

Nominal size 10 = 10

Relief function from to:

A	→	T	= VA	
B	→	T	= VB	
P	→	T	= VP	
A	→	T and B	→ T	= VC
A	→	B and B	→ A	= VD
TB1	→	TA2	= VT	

Further details in clear text

No code = mineral oils
 V = phosphate ester

50 = Pressure adjustable up to 5 MPa
 100 = Pressure adjustable up to 10 MPa
 200 = Pressure adjustable up to 20 MPa
 315 = Pressure adjustable up to 31.5 MPa

B= Technology of Beijing Huade Hydraulic

40 = Series 40 to 49
 (40 to 49 = unchanged installation and connection dimensions)

Adjustment element

1 =	Rotary knob
2 =	Sleeve with hexagon and protective cap
3 =	Lockable rotary knob with scale
7 =	Rotary knob with scale

Symbols

Type ZDB 10 VA ..

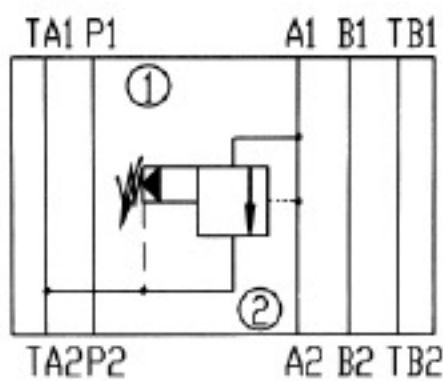

Type ZDB 10 VB ..

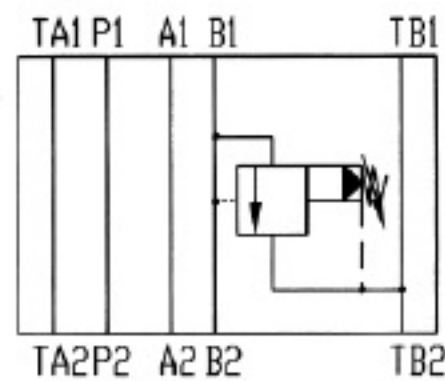

Type ZDB 10 VP ..

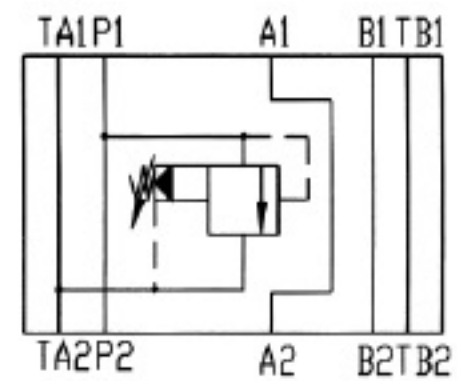

Type ZDB 10 VT ..

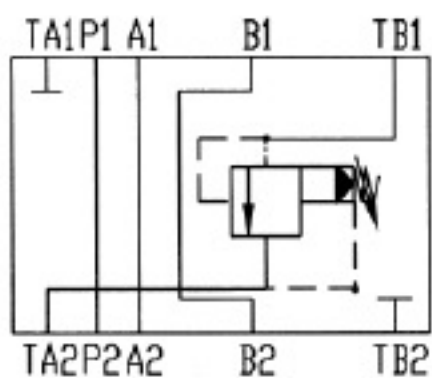

Type Z2DB 10 VC ..

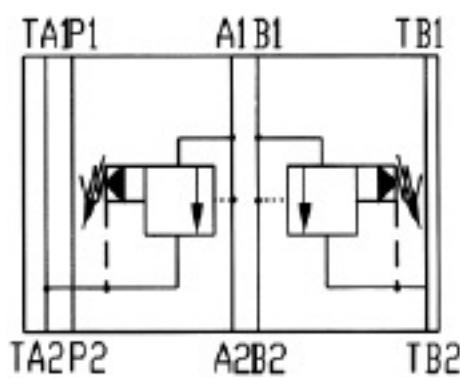

Type Z2DB 10 VD ..

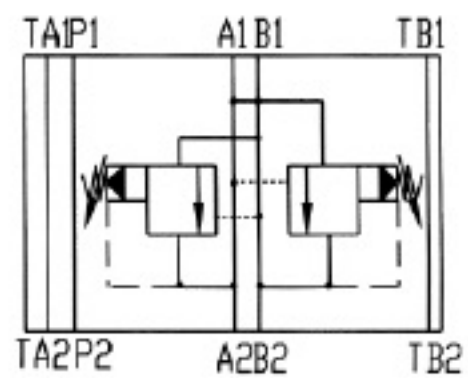

Technical data (for applications outside these parameters, please consult us!)

Pressure fluid	Mineral oil (for NBR seal), or phosphate ester (for FPM seal)	
Pressure fluid - temperature range (°C)	-30 to +80	
Viscosity range (mm ² /s)	10-800	
Degree of fluid contamination	Maximum permissible degree of contamination of the fluid is to NAS 1638, class 9. $\beta_{10} \geq 75$	
Operating pressure, max. (MPa)	up to 31.5	
Pressure adjustable, max. setting (MPa)	up to 5, up to 10, up to 20, up to 31.5	
Flow, max. (L/min)	up to 100	
Weight (Kg)	Type ZDB 10	approx. 2.4
	Type Z2DB 10	approx. 2.6

Characteristic curves (measured at $v = 41 \text{ mm}^2/\text{s}$ and $t = 50^\circ \text{ C}$)

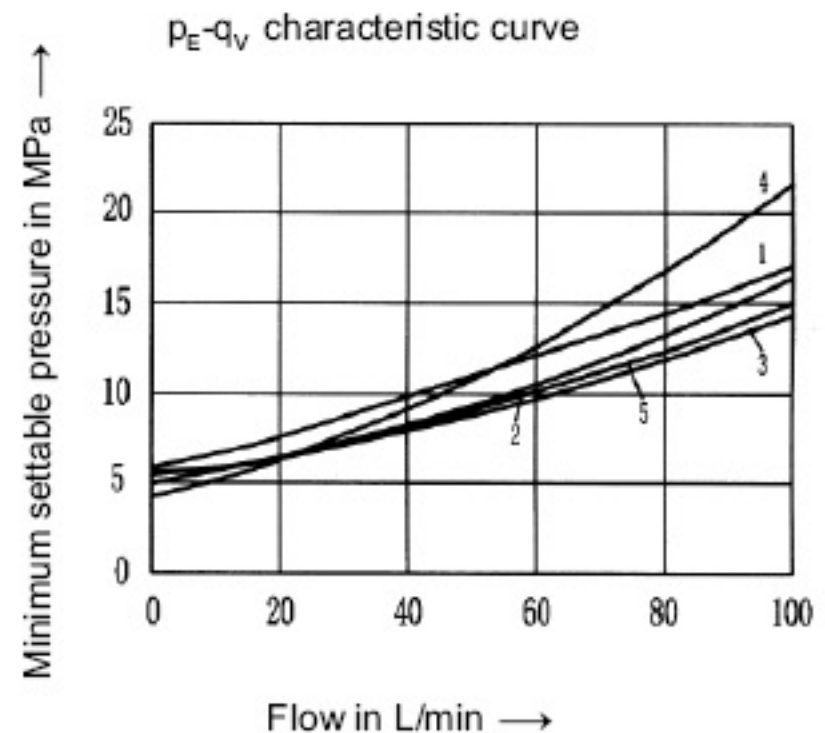
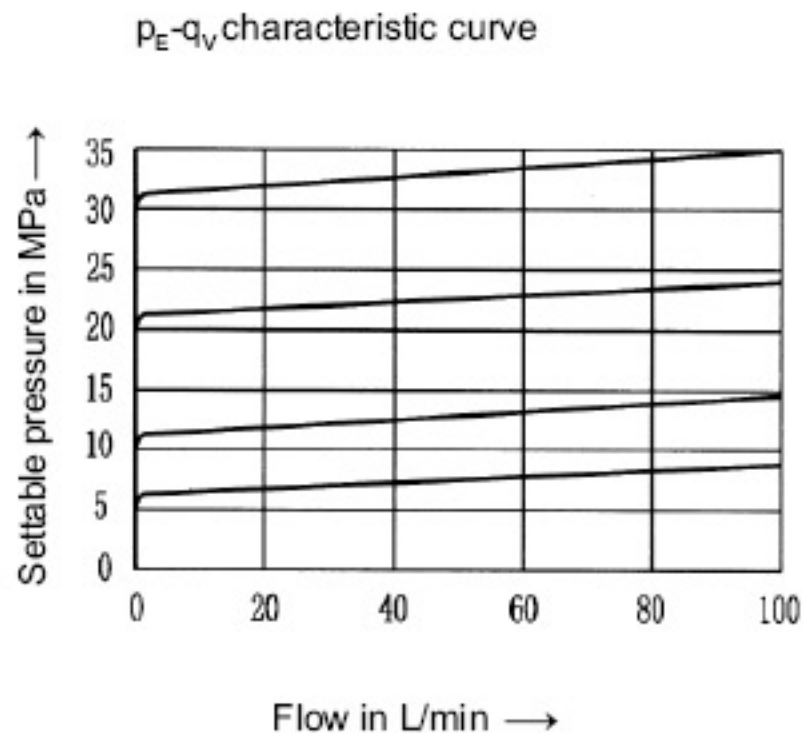

- 1 VA , VB
- 2 VP
- 3 VC
- 4 VD (A to B)
- 5 VD (B to A)

Type ZDB10 VA...
 Type ZDB10 VT...
 Type ZDB10 VP...

Dimensions	ZDB10	
	VA VP	VT
B	69	70
H	26	25
L1	227	218
L2	203	194
L3	117	105
L4	57.6	60.9
L5	50.3	53.6
L6	4	0.7
L7	41.5	31.8

- 1 Nameplate
- 2 Adjustment element 1
- 3 Adjustment element 2
- 4 Adjustment element 3
- 5 Adjustment element 7
- 6 Space required to remove key
- 7 Valve fixing screw holes
- 8 Lock nut 24 A/F
- 9 Hexagon 10 A/F
- 10 O-rings 12 x 2 for ports A2, B2, P2, TA2, TB2
- 11. O-ring plate 72 x 60 x 1.5 (only for models VA, VB and VP)
- 12 Counter bores only for models VC, VD and VT
- 13 Models ZDB 10 VA and VP
- 14 Model ZDB 10 VT
- 15 Hexagon 30 A/F,
Tightening torque $M_A = 50 \text{ Nm}$

Valve fixing screws M6
 Tightening torque $M_A = 15.5 \text{ Nm}$

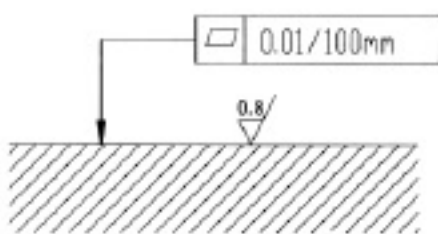

Required surface finish of mating piece

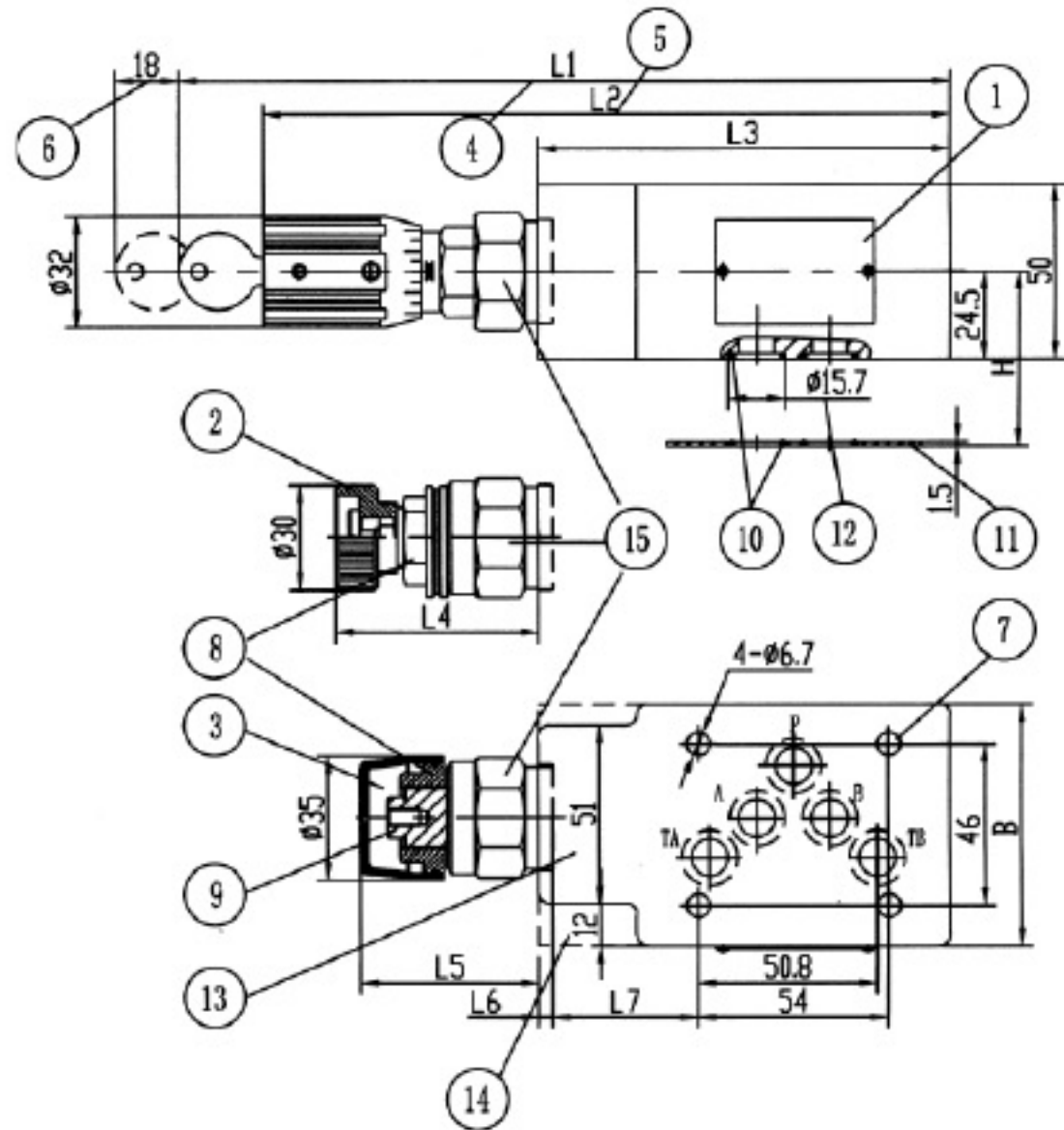

Type ZDB10 VB...

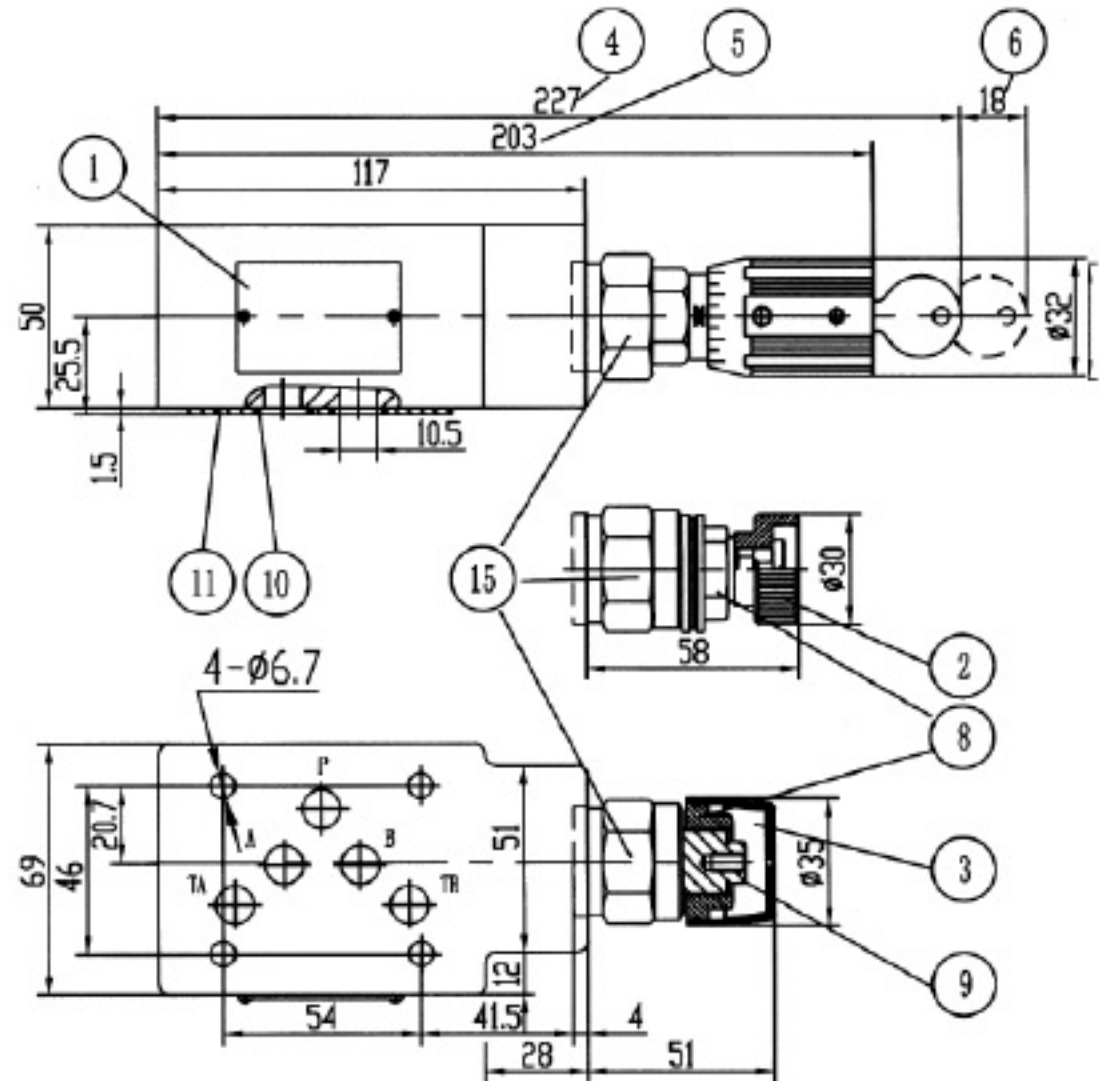

Type Z2DB10 VC...

Type Z2DB10 VD...

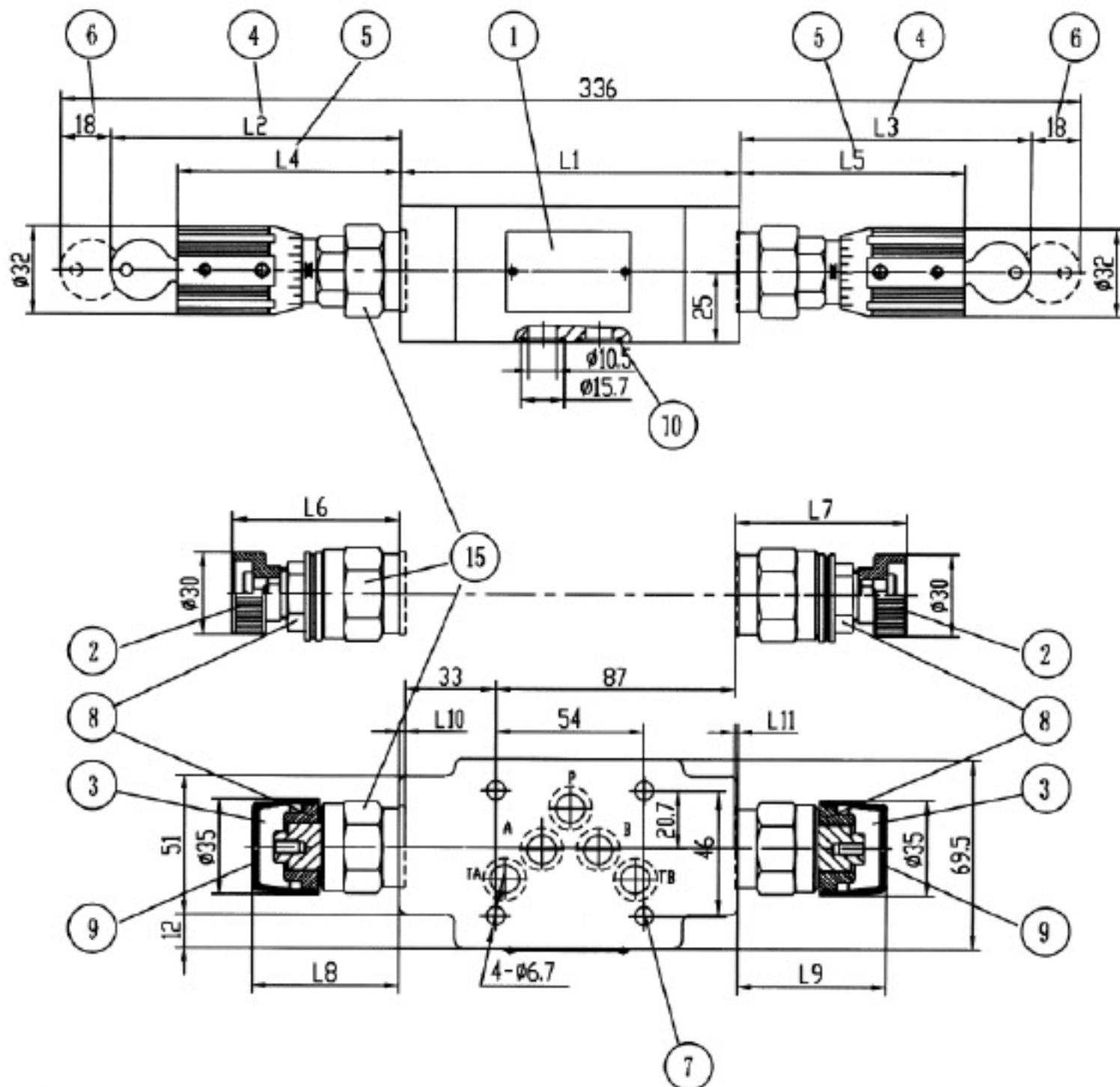

- 1 Nameplate
- 2 Adjustment element 1
- 3 Adjustment element 2
- 4 Adjustment element 3
- 5 Adjustment element 7
- 6 Space required to remove key
- 7 Valve fixing screw holes
- 8 Lock nut 24 A/F
- 9 Hexagon 10 A/F
- 10 O-rings 12 x 2 for ports A2, B2, P2, TA2, TB2
- 15 Hexagon 30 A/F, Tightening torque $M_A = 50 \text{ Nm}$

Valve fixing screws M6
Tightening torque $M_A = 15.5 \text{ Nm}$,

Required surface finish of mating piece



dimensions	Z2DB10	
	VC	VD
L1	123	132
L2	111	107
L3	112	112
L4	89	85
L5	90	90
L6	59	56
L7	60	56
L8	52	49
L9	53	49
L10	2	6
L11	1	6

NOTICE

1. The fluid must be filtered. Minimum filter fineness is 20 μm .
2. The tank must be sealing up and an air filter must be installed on air entrance.
3. Products without subplate when leaving factory, if need them, please ordering specially.
4. Valve fixing screws must be high intensity level (class 10.9). Please select and use them according to the parameter listed in the sample book.
5. Roughness of surface linked with the valve is required to $\frac{0.8}{\nabla}$.
6. Surface finish of mating piece is required to 0.01/100mm.

Notice

1. The fluid must be filtered. Minimum filter fineness is 20 μm .
2. The tank must be sealing up and an air filter must be installed on air entrance.
3. Products without subplate when leaving factory, if need them, please ordering specially.
4. Valve fixing screws must be high intensity level (class 10.9). Please select and use them according to the parameter listed in the sample book.
5. Roughness of surface linked with the valve is required to $\frac{0.8}{\sqrt{\text{ }}$.
6. Surface finish of mating piece is required to 0.01/100mm.