

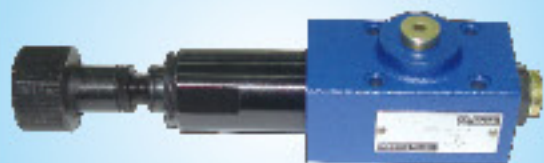

**Huade**



**Hydraulic valves**



**Pressure Valves**

**Catalogue**



**BEIJING HUADE HYDRAULIC INDUSTRIAL GROUP CO.,LTD.**

# CONTENTS

## Pressure Valves

| No. | Name   | Type               | Size    | Pressure max.(MPa) | Page |
|-----|--|--------------------|---------|--------------------|------|
| 1   | Pressure remote relief valve   | DBT/DBWT           |         | 31.5               | 1    |
| 2   | Pressure relief valve , direct operated                              | DBD                | 6~30    | 63                 | 5    |
| 3   | Direct operated pressure relief valve,sandwich plate                 | Z2DBD6             | 6       | 31.5               | 11   |
| 4   | *Pilot operated pressure relief Valve,sandwich plate                 | ZDB/Z2DB           | 6       | 31.5               | 15   |
| 5   | Pilot operated pressure relief valve,sandwich plate                  | ZDB/Z2DB           | 10      | 31.5               | 21   |
| 6   | Pilot operated pressure relief valve,cartridge connection            | DB...K             | 6、10、20 | 31.5               | 27   |
| 7   | Pressure relief valve  | DB/DBW...30B/...   | 10~30   | 31.5               | 37   |
|     | Pressure relief valve(New series)                                    | DB/DBW...50B/ ...  | 10~32   | 35                 | 43   |
| 8   | Pressure relief valves   | DB3U               | 10~30   | 31.5               | 53   |
| 9   | *Check-Q-meter   | DC                 | 10~30   | 31.5               | 61   |
| 10  | Pressure reducing valve direct operated,sandwich plate               | ZDR6D...30B        | 6       | 21                 | 67   |
|     | *Pressure reducing valve direct operated,sandwich plate (New series) | ZDR6D...40B        | 6       | 21                 | 71   |
| 11  | *Pressure reducing valve   | ZDR6DP0...40B/40YM | 6       | 4.0                | 75   |
| 12  | Direct operated pressure reducing valve,sandwich plate               | ZDR10D...40B/      | 10      | 21                 | 79   |
| 13  | *Direct operated pressure reducing valve,sandwich plate(New series)  | ZDR10D-50B/        | 10      | 21                 | 83   |
| 14  | *Pressure reducing valve direct operated                             | DR5DP              | 5       | 31.5               | 87   |
|     | *Pressure reducing valve direct operated                             | DR6DP              | 6       | 21                 | 91   |
|     | *Pressure reducing valve direct operated                             | DR10DP             | 10      | 21                 | 95   |



# CONTENTS

## Pressure Valves

| No. | Name   | Type           | Size     | Pressure max.(MPa) | Page |
|-----|--|----------------|----------|--------------------|------|
| 15  | Pilot operated pressure reducing Valve               | DR...30B/...   | 10、20、30 | 31.5               | 99   |
|     | *Pilot operated pressure reducing Valve (New series) | DR...50B/      | 10~25    | 31.5               | 105  |
| 16  | *Direct operated pressure sequence Valve             | DZ5DP          | 5        | 31.5               | 111  |
|     | *Direct operated pressure sequence valve             | DZ6DP          | 6        | 31.5               | 115  |
|     | *Direct operated pressure sequence valve             | DZ10DP         | 10       | 21                 | 119  |
| 17  | Pressure sequence valve pilot operated               | DZ...30B/      | 10~30    | 21                 | 123  |
|     | *Pressure sequence valve pilot operated (New series) | DZ...-50B/     | 10、20、30 | 31.5               | 129  |
| 18  | Pressure shut-off valve pilot operated               | DA/DAW...-30B/ | 10、20、30 | 31.5               | 135  |
|     | *Pressure shut-off valve pilot operated (New series) | DA/DAW...-50B/ | 10、20、30 | 31.5               | 141  |
| 19  | Subplate   | —              | —        | —                  | 148  |

\* \* : New products, for ordering, please consult us, telephone:+86-10-69083290



### Other Huade Hydraulics Catalogues for Valves

- Directional Valves
- Flow Control Valves
- Proportional Valves
- Cartridge Valves



## Symbols

ZDR10DA...-40B/...YM...

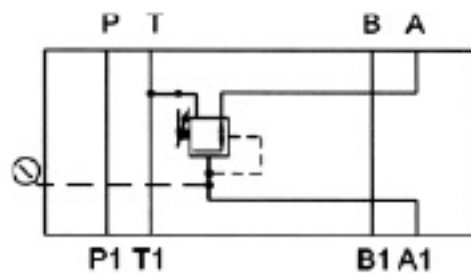

ZDR10DA...-40B/...Y...

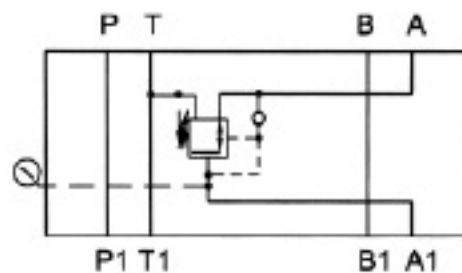

ZDR10DP...-40B/...YM...

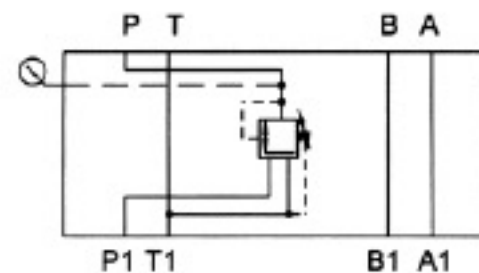

ZDR10DB...-40B/...YM...

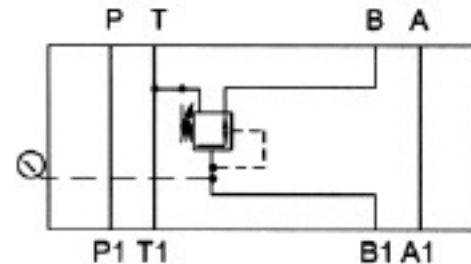

ZDR10DB...-40B/...Y...

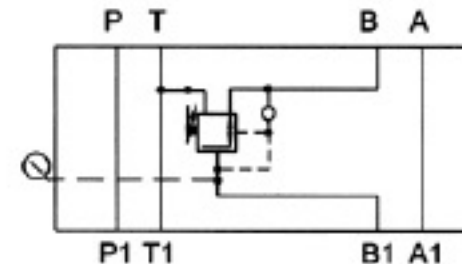

## Ordering details

Z DR 10 D - 40 B / Y \*

Sandwich plate design = Z

Pressure reducing valve = DR

Size 10 = 10

Direct operated = D

Pressure reduction in port A = A  
 Pressure reduction in port B = B  
 Pressure reduction in port P = P

Setting elements  
 Rotary knob = 1  
 Hex. head screw with protective cap = 2  
 Lockable rotary knob with scale = 3

Series 40 to 49 = 40  
 (40 to 49 = unchanged installation and connection dimensions)

Further details in clear text

No code. = mineral oils  
 V = phosphate ester

No code. = with check valve  
 (only possible for pressure reduction in port A,B)  
 M = without check valve

Y = Pilot oil feed internal, drain external

25 = max. secondary pressure 2.5 MPa  
 75 = max. secondary pressure 7.5 MPa  
 150 = max. secondary pressure 15 MPa  
 210 = max. secondary pressure 21 MPa

B = Technology of Beijing Huade Hydraulic

## Technical data (For applications outside these parameters, please consult us!)

|                                    |                      |  |
|------------------------------------|----------------------|--|
| Weight                             | (Kg)                 | approx. 2.8  |
| Pressure fluid                     |                      | Mineral oil (for NBR seal) or phosphate ester (for FPM seal)             |
| Pressure fluid - temperature range | (°C)                 | -30 to +80   |
| Viscosity range                    | (mm <sup>2</sup> /s) | 10 to 800  |
| Degree of fluid contamination      |                      | recommend a filter with a minimum retention rate of $\beta_{10} \geq 75$ |
| Max. operating pressure Port P     | (MPa)                | up to 31.5   |
| Secondary pressure (output)        | (MPa)                | up to 21   |
| Back pressure Ports T (Y)          | (MPa)                | up to 15   |
| Max. flow                          | (L/min)              | 50   |





|   |  |             |               |                 |
|---|--|-------------|---------------|-----------------|
| BEIJING HUADE<br>HYDRAULIC INDUSTRIAL<br>GROUP CO.,LTD. | <b>Direct operated pressure reducing valve,<br/>sandwich plate,type ZDR 10D...50B/(New Series)</b> |             |               | RE26585/12.2004 |
|   | Size 10  | up to 21MPa | up to 80L/min |                 |

**Features:**

- Sandwich plate design
- Pressure reduction in ports A, B or P
- 4 adjustment elements:
  - Rotary knob
  - Hex. head screw with protective cap
  - Lockable rotary knob with scale
  - Rotary knob with scale
- 4 pressure ratings
- optional check valve
- Porting pattern to DIN 24 340, form A,ISO 4401 and CETOP-RP 121H

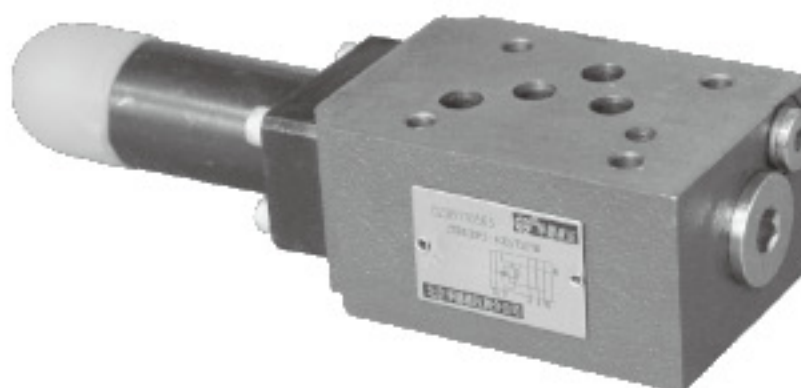

**Functional, section**

The pressure reducing valve type ZDR 10 D.. is a 3-way direct operated valve of sandwich plate design with a pressure relief function on the secondary side. It is used to reduce the system pressure.

The pressure reducing valve basically consists of the housing (1), the control spool (2), a compression spring (3),and the adjustment (4) as well as an optional check valve.

The secondary pressure is set by the pressure adjustment element (4). Model "DA"

At rest, the valve is normally open, and fluid can flow unhindered from port A1 to port A2. The pressure in port A2 is at the same time via the control line (5) present at the spool area opposite to the compression spring (3). When the pressure in port A2 exceeds the pressure level set at the compression spring (3), the control spool (2) moves into the control position against the compression spring (3) and holds the set pressure in port A2 constant.

The control pressure and pilot oil are taken from port A2 via control line (5).

If the pressure in port A2 rises still further due to external forces, the control spool (2) is moved still further towards the compression spring (3).

This causes a flow path to be opened at port A2 via control land (5) on the control spool (2) and housing (1) to tank (port TB). Sufficient fluid then flows to tank to prevent any further rise in pressure.

The spring chamber (7) is always drained to tank externally via port TA .

A pressure gauge connection (8) permits the secondary pressure at the valve to be monitored.

It is only possible to fit a check valve for free flow in ports A2 to A1 in version "DA".

Models "DP" and "DB"

In model "DP", the pressure is reduced in port P1. The control pressure and the pilot oil is taken internally from port P1.

In model "DB", the pressure in port P1 is reduced, and the pilot oil taken from port B.

Attention!

When the directional valve is in the switched position P to A, pressure in port B must not exceed the set secondary pressure.

Otherwise, pressure in port A will be reduced.

If used without a directional valve, TA and TB must be interconnected (e.g. in the cover plate).

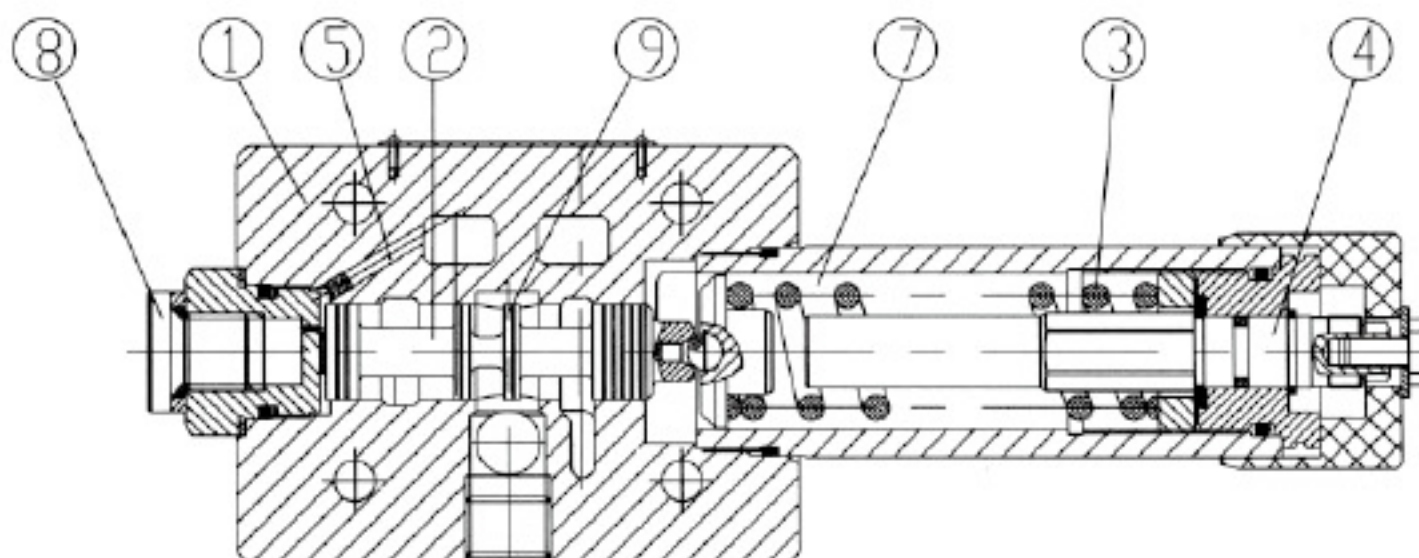

ZDR10DB1-50B/...YM

**Symbols** ( ① =valve side, ② =subplate side)

ZDR10DP...-50B/...YM...

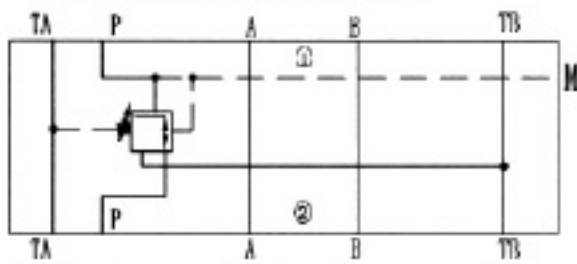

ZDR10DA...-50B/...YM...

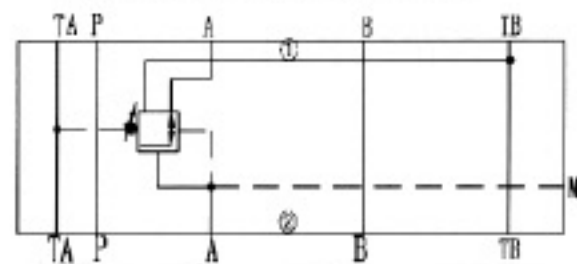

ZDR10DB...-50B/...YM...

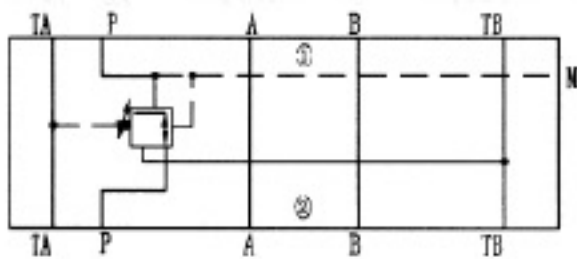

ZDR10DA...-50B/...Y...

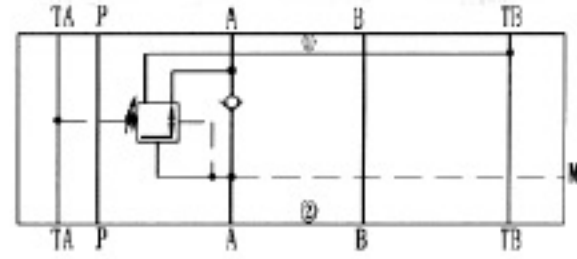

**Ordering details**

Z DR 10 D - 50 B / Y \*

Sandwich plate design = Z

Pressure reducing valve = DR

Size 10 = 10

Direct operated = D

Pressure reduction in port A = A  
 Pressure reduction in port B = B  
 (Pilot oil from port B)  
 Pressure reduction in port P = P

Setting elements  
 Rotary knob = 1  
 Hex. head screw with protective cap = 2  
 Lockable rotary knob with scale = 3  
 Rotary knob with scale = 7

Series 50 to 59 = 50  
 (50 to 59 = unchanged installation and connection dimensions)

Further details in clear text

No code. = mineral oils  
 V = phosphate ester

No code. = with check valve  
 (only possible for pressure reduction in port A)  
 M = without check valve

Y = Pilot oil feed internal, drain external

25= max. secondary pressure 2.5 MPa  
 75= max. secondary pressure 7.5 MPa  
 150= max. secondary pressure 15.0 MPa  
 210= max. secondary pressure 21.0 MPa

B = Technology of Beijing Huade Hydraulic

**Technical data**

|   |                      |   |
|---|----------------------|---|
| Weight  | (kg)                 | approx. 2.8   |
| Pressure fluid                                |                      | Mineral oil (for NBR seal) or phosphate ester (for FPM seal)          |
| Pressure fluid-temperature range <sup>3</sup> | (°C)                 | -30 to +80  |
| Viscosity range                               | (mm <sup>2</sup> /s) | 10 to 800   |
| Degree of fluid contamination                 |                      | recommend a filter with a minimum retention rate of $\beta_{10} > 75$ |
| Max.operating Pressure (inlet)                | (MPa)                | up to 31.5  |
| Secondary pressure(output)                    | (MPa)                | up to 2.5, up to 7.5, up to 15.0, up to 21.0                          |
| Back pressure port                            | (MPa)                | up to 16.0  |
| Max.flow                                      | (L/min)              | 80  |

**Characteristic curves** (measured at  $v = 41 \text{ mm}^2/\text{s}$  and  $t = 50^\circ\text{C}$ )

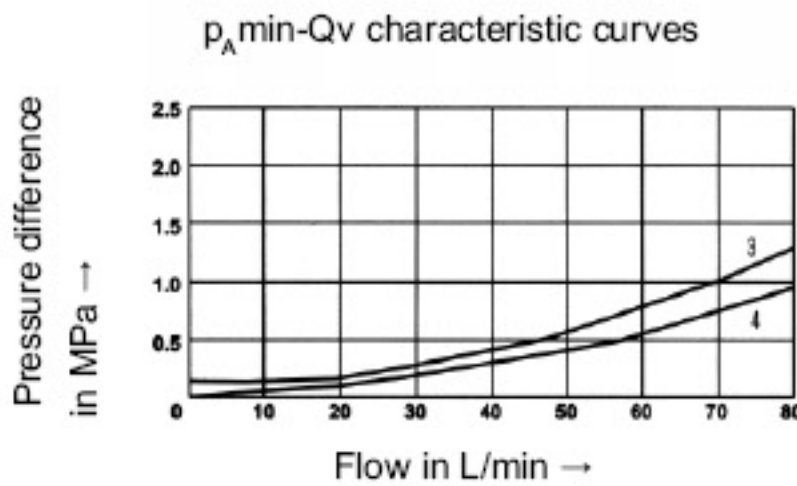
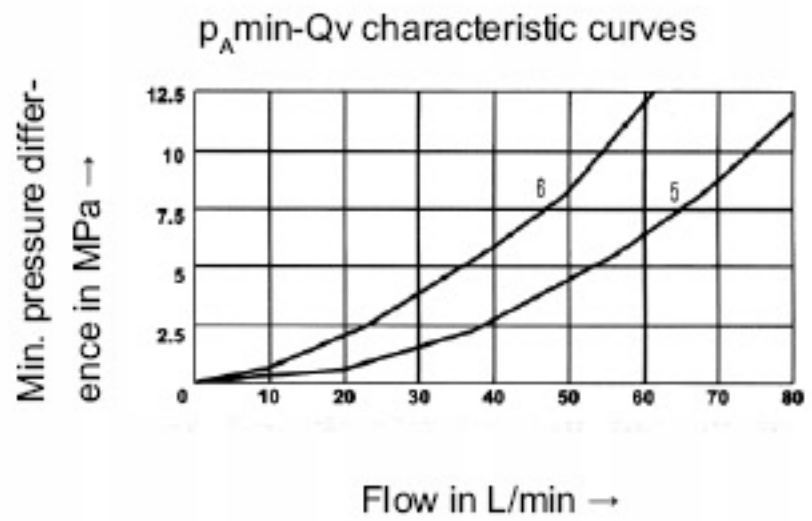
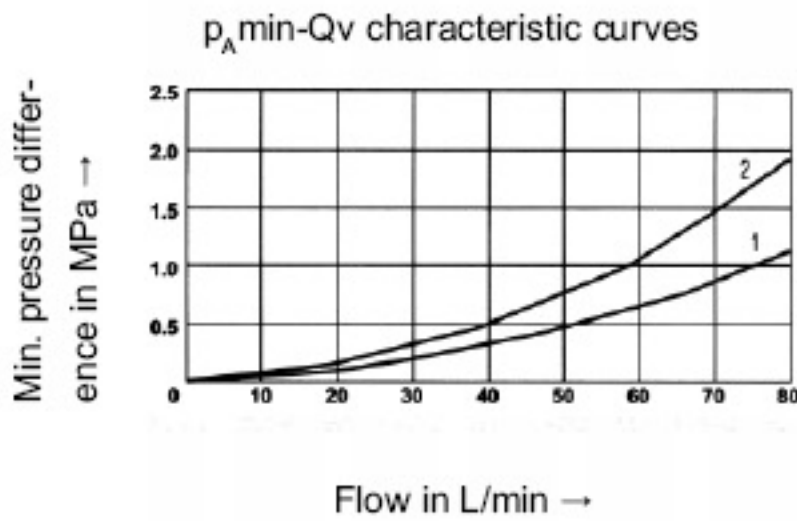
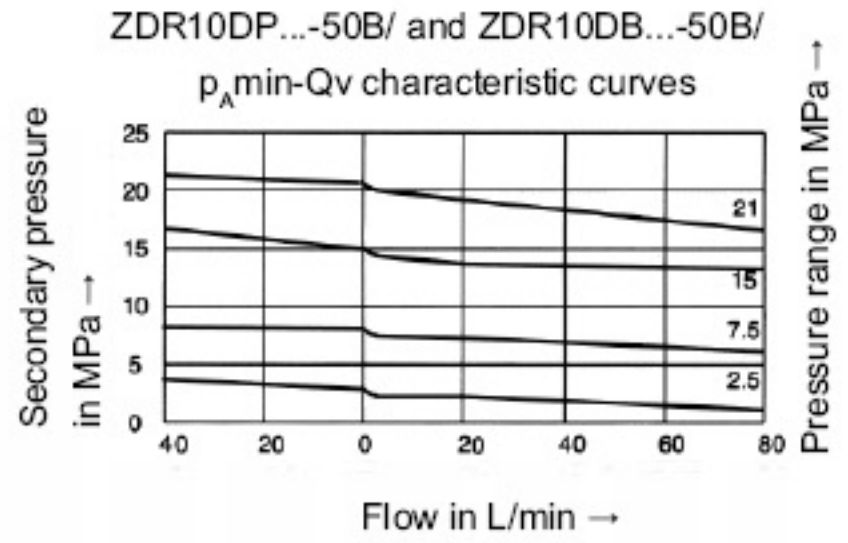
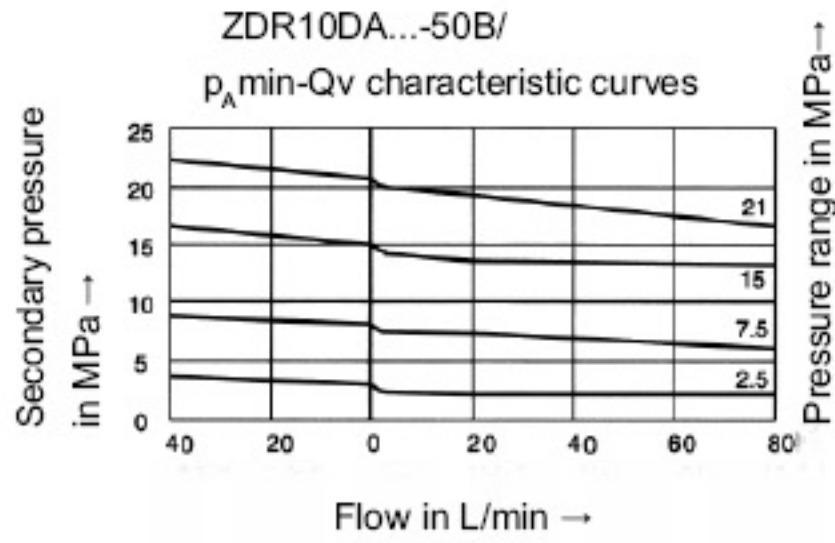

1. A1 to A2
2. A2 to TB (3rd. flow path)
3. A2 to A1(flow via check valve only)
4. A2 to A1(check valve and fully open control cross section)
5. P2 to TB
6. P1 to TB (3rd. flow path)

The characteristic curves for the pressure relief function are valid for the outlet pressure = zero over the entire flow range!

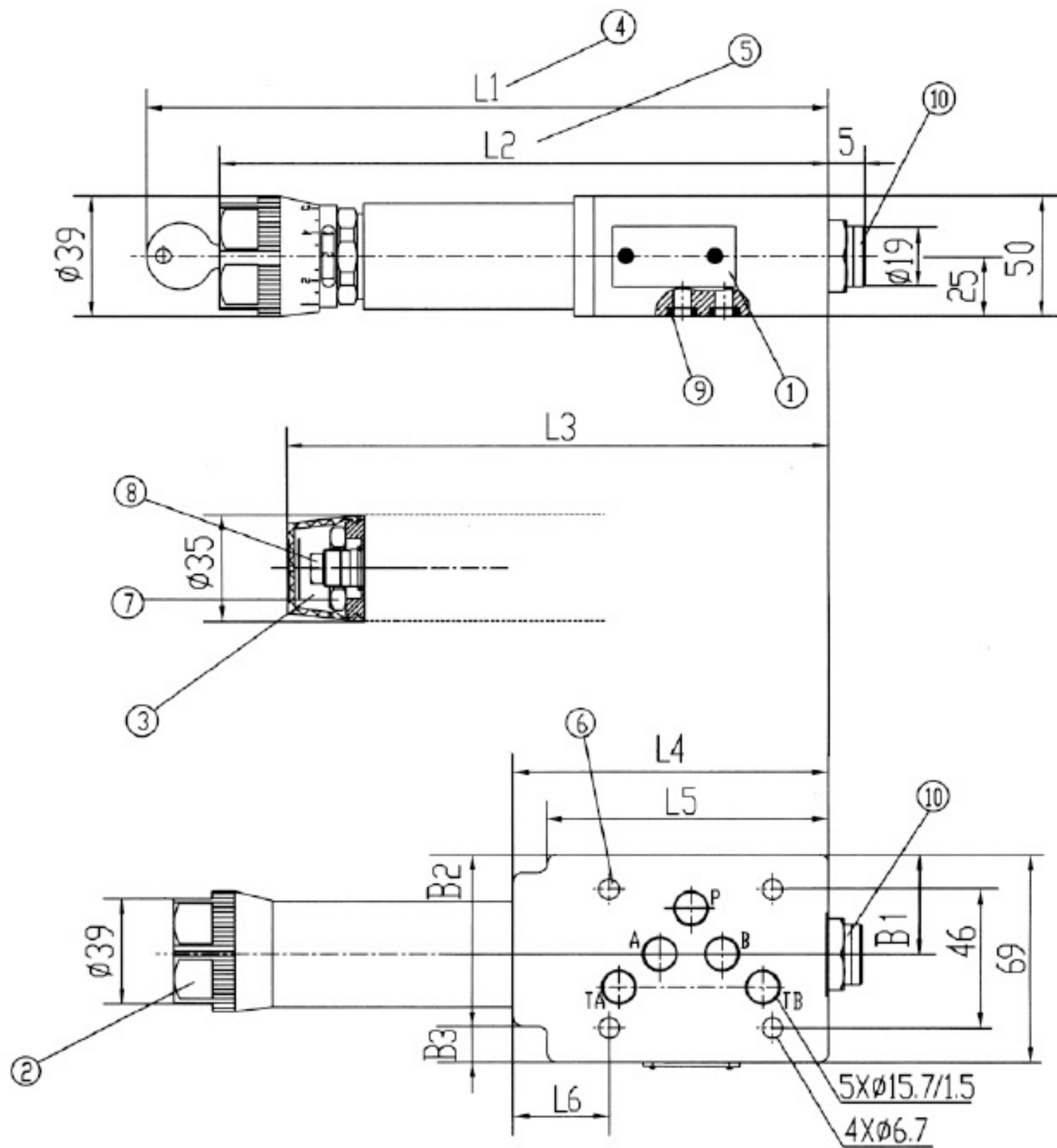

1. Nameplate
2. Adjustment1
3. Adjustment2
4. Adjustment3
5. Adjustment7
6. Fixed screw hole of valve
7. Lock nut 24 A/F
8. Hexagon 10 A/F
9. O-ring 12X2 apply to the oil orifice A2, B2, P2, T2 (Y)
10. Pressure gauge port G1/4" ; 12 deep intend hexagon 6A/F

Required surface finish of mating piece

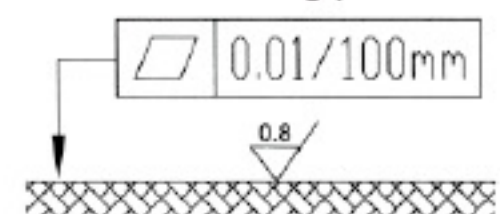

## Notice

1. The fluid must be filtered. Minimum filter fineness is 20  $\mu\text{m}$ .
2. The tank must be sealing up and an air filter must be installed on air entrance.
3. Products without subplate when leaving factory, if need them, please ordering specially.
4. Valve fixing screws must be high intensity level (class 10.9). Please select and use them according to the parameter listed in the sample book.
5. Roughness of surface linked with the valve is required to  $\frac{0.8}{\sqrt{\text{ }}$ .
6. Surface finish of mating piece is required to 0.01/100mm.