



Axial Piston Fixed Motor HA2FM/E Series 61/69/63

Series:61/69
Displacement:23-180 mL/r
Rated Pressyre:30 MPa
Max.Pressyre:35 MPa

Series:63
Displacement:23-160 mL/r
Rated Pressyre:40 MPa
Max.Pressyre:45 MPa



Features



- Axial piston motor of bent-axis design for hydrostatic drives in open and closed circuits
- The output speed is directly proportional to the input flow and inversely proportional to the displacement
- The output torque increases with the pressure differential between the high- and low-pressure sides
- Tapered piston with sealed piston ring
- Pressure relief valve for protection of hydrostatic drives against overload
- Compact design and high total efficiency

Contents



- Model Code.....02
- Structure.....06
- Technical Data.....08
- HA2FM Installation Dimensions,23/28/3209
- HA2FM Installation Dimensions,45.....11
- HA2FM Installation Dimensions,56/63..... 13
- HA2FM Installation Dimensions,80/90..... 15
- HA2FM Installation Dimensions,107/125.....17
- HA2FM Installation Dimensions,160/180.....19
- HA2FE Installation Dimensions,23-180.....21
- Flushing and Boost-pressure Valve.....23
- Pressure Relief Valve.....25
- Counterbalance Valve BVD.....26
- Installation Instructions.....29



> Model Code

	c	A		I	K	M	N	P	R	V	Z		Zaa
HA2F			/		W	-					-		+

Axial piston unit

—	Bent-axis design, fixed displacement piston motor	HA2F
---	---	------

Type

c		23	28	32	45	56	63	80	90	107	125	160	180	
	Standard	●	●	●	●	●	●	●	●	●	●	●	●	M
	Plug-in	○	○	○	●	●	●	●	●	●	●	●	●	E

Displacement

A	Geometric displacement in mL/r	23	28	32	45	56	63	80	90	107	125	160	180	
		●	●	●	●	●	●	●	●	●	●	●	●	●

Series

I		23	28	32	45	56	63	80	90	107	125	160	180	
	7-piston 30MPa	●	●	●	●	●	●	●	●	●	●	●	○	61
	7-piston 40MPa	●	●	●	●	●	●	●	●	●	●	●	○	63
	9-piston 30MPa	○	○	○	○	○	○	○	○	○	○	○	●	69

Direction of rotation (viewed on drive shaft)

K		23	28	32	45	56	63	80	90	107	125	160	180	
	Bi-directional	●	●	●	●	●	●	●	●	●	●	●	●	W

Sealing material

M		23	28	32	45	56	63	80	90	107	125	160	180	
	NBR seal + FKM Shaft seal	○	○	○	○	○	○	○	○	○	○	○	○	N
	NBR seal	●	●	●	●	●	●	●	●	○	○	●	●	P
	FKM seal	●	●	●	●	●	●	●	●	●	●	●	●	V

Drive shaft

N		23	28	32	45	56	63	80	90	107	125	160	180		
	Splined shaf DIN 5480	●	●	●	●	●	●	●	●	●	●	●	●	●	Z
		●	●	●	●	●	●	●	●	●	●	●	●	●	A
	Parallel keyed shaf DIN 6885	●	○	●	●	●	●	○	○	●	○	○	○	○	P
		●	●	●	○	●	●	●	●	●	○	○	○	○	B
Splined shaft SAE J744 ¹⁾	○	○	○	●	○	○	○	○	○	○	○	○	○	S	

1) : Splined shaft SAE J744(ANSI B92.1a)1 1/4 14T 12/24 DP



➤ Model Code

	c	A		I	K	M	N	P	R	V		Z		Zaa
HA2F			/		W	-					-		+	

Mounting flange ¹⁾

P		23	28	32	45	56	63	80	90	107	125	160	180	
	4-hole, as per ISO 3019-2	●	●	●	●	●	●	●	●	●	●	●	●	B
	2-hole, ISO 3019-2 equivalent	○	○	○	●	●	●	●	●	●	●	●	●	L

Working port

R		23	28	32	45	56	63	80	90	107	125	160	180		
	SAE flange ports A and B at rear	●	●	●	●	●	●	○	○	○	○	○	○	010	
	SAE flange ports A and B at side	●	●	●	●	●	●	●	●	●	●	●	○	020	
	SAE flange ports A and B at side With flushing valve	●	●	●	●	●	●	●	●	●	●	●	○	027	
	Metric threaded ports A and B at side	●	●	●	●	●	●	○	○	○	○	○	○	030	
	Metric threaded ports A and B at side With flushing valve	●	●	●	○	○	○	○	○	○	○	○	○	037	
	Metric threaded ports A and B, at side&rear With side threads plugged	●	●	●	●	●	●	○	○	○	○	○	○	040	
	SAE flange ports A and B at bottom	○	○	○	●	●	●	●	●	●	●	○	○	100	
	With 1-stage pressure relief valve (without pressure boost facility) Port plate without counterbalance valve	○	○	○	○	○	○	○	○	○	●	●	○	○	171
	With 1-stage pressure relief valve (without pressure boost facility) Port plate with HBVD counterbalance valve	○	○	○	○	○	○	○	○	○	●	●	○	○	178
	With 1-stage pressure relief valve (without pressure boost facility) Port plate without counterbalance valve	○	○	○	○	○	○	○	●	●	●	●	○	○	181
	With 1-stage pressure relief valve (without pressure boost facility) Port plate with HBVD counterbalance valve	○	○	○	○	○	○	○	●	●	●	●	●	○	188
	With 1-stage pressure relief valve (without pressure boost facility)	○	○	○	○	○	○	○	○	●	○	○	○	○	191
With 2-stage pressure relief valve (with pressure boost facility)	○	○	○	○	○	○	○	○	○	○	○	○	○	192	

Valve	Without valve	0
	Pressure relief valve (without pressure boost facility)	1
	Pressure relief valve (with pressure boost facility)	2
	With flushing valve	7
	With counterbalance valve	8

¹⁾ : B: for HA2FM only; L: for HA2FE only.



> Model Code

	c	A		I	K	M	N	P	R	V		Z		Zaa
HA2F			/		W	-					-		+	

Speed sensor

		23	28	32	45	56	63	80	90	107	125	160	180		
V	Without speed sensor(without code)	●	●	●	●	●	●	●	●	●	●	●	●		
	Prepared for HDD speed sensor	●	○	●	●	●	○	●	●	●	●	●	●	F0	
	With HDD Hall-effect speed sensor (without connector)	●	○	●	●	●	○	●	●	●	●	●	●	F	
	With HDD Hall-effect speed sensor (DTM04-4P connector)	○	○	○	○	○	○	○	○	○	○	●	●	●	F1
	With HDD Hall-effect speed sensor (DTM04-4P connector)	○	○	○	○	○	○	○	○	○	○	○	○	○	F2

Special configuration

		23	28	32	45	56	63	80	90	107	125	160	180		
Z	Without special configuration (without code)	●	●	●	●	●	●	●	●	●	●	●	●		
	Low-pressure flushing 0.8 MPa	○	●	●	○	●	○	○	○	○	○	○	○	A	
	Flow of flushing valve 3 L/min	○	●	○	○	○	○	○	○	○	○	○	○	-C030	
	Flow of flushing valve 3.5 L/min	○	○	○	○	○	○	●	○	○	○	○	○	-C035	
	Flow of flushing valve 5 L/min	○	○	○	○	○	○	●	●	○	○	○	○	-C050	
	Flow of flushing valve 8 L/min	○	○	○	○	○	●	●	●	●	○	○	○	-C080	
	Flow of flushing valve 10 L/min	○	○	○	○	○	●	●	○	○	○	○	○	-C100	
	End cap with differential valve (constant rotational speed)	○	○	○	○	○	○	○	○	○	○	○	○	○	-CS
	End cap with on/off valve	○	○	○	○	○	○	○	○	○	○	○	○	○	-DS
	Special configuration	●	●	●	●	●	●	●	●	●	●	●	●	●	***



> Model Code

	c	A		I	K	M	N	P	R	V	Z		Zaa
HA2F			/		W	-					-		+

Counterbalance valve

		23	28	32	45	56	63	80	90	107	125	160	180
Zaa	HBVD20W27L/41B-V01K00D0600S00A	○	○	○	○	○	○	●	●	○	○	○	○
	HBVD20W28L/41B-V01K00D0600S00A	○	○	○	○	○	○	○	○	●	●	○	○
	HBVD25W38L/41B-V16K00D1200S00A	○	○	○	○	○	○	○	○	●	○	●	○
	HBVD25W38L/41B-V16K00D1200S00	○	○	○	○	○	○	○	○	○	●	●	○
	HBVD25W38L/41B-V07K00D0600S00A	○	○	○	○	○	○	○	○	○	○	●	●
	HBVD25W38L/41B-V07K00D0800S00A	○	○	○	○	○	○	○	○	○	○	●	○

● Available ○ On request — Not available ■ Recommended model



> Structure

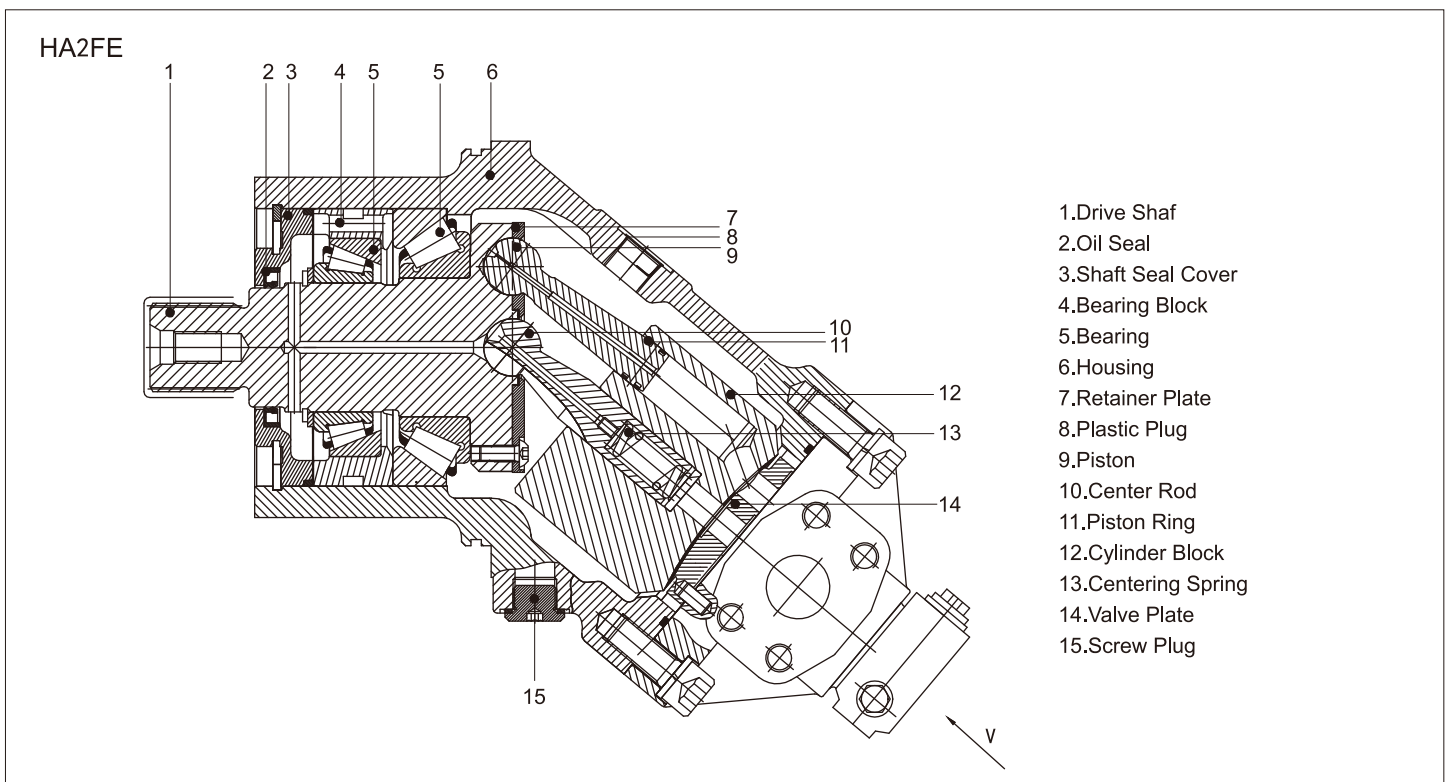
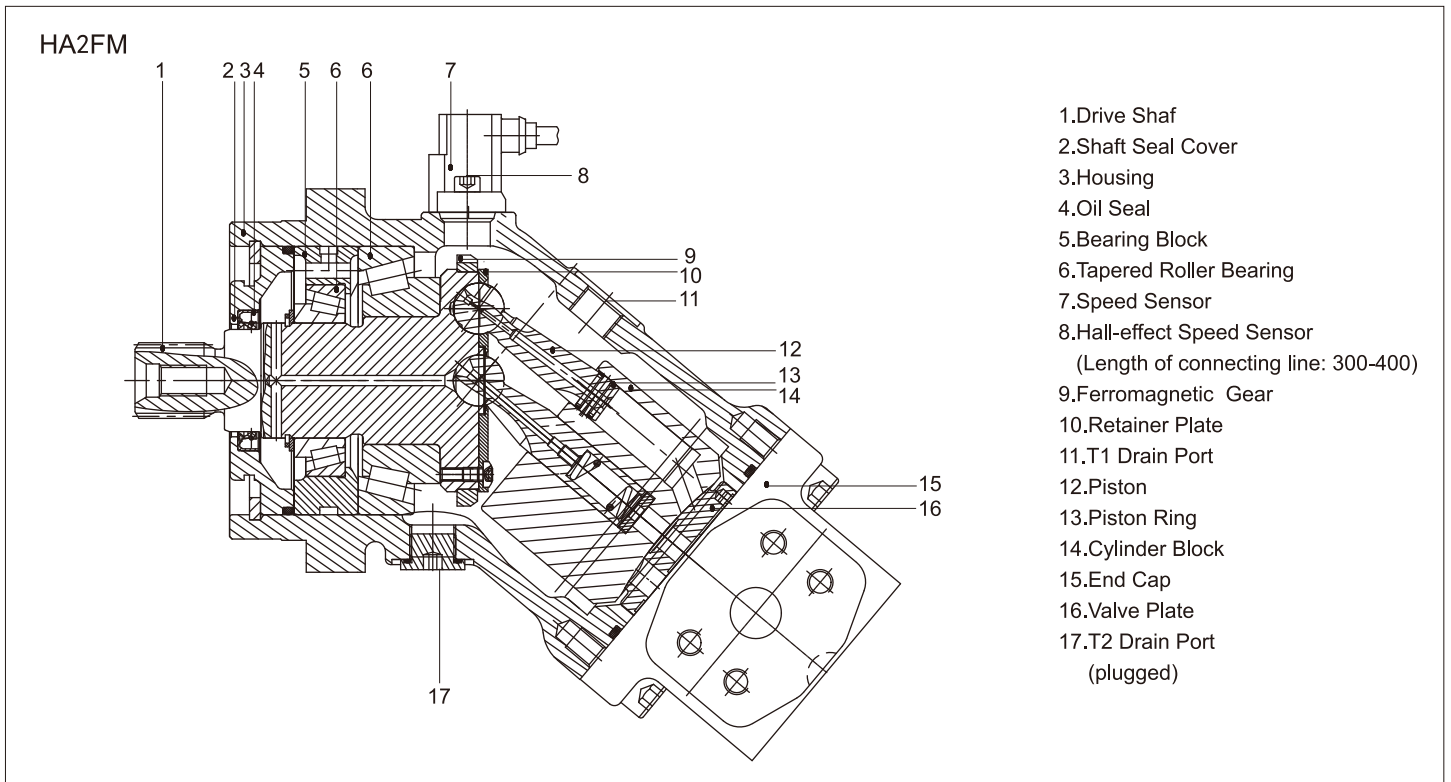



➤ Hydraulic Fluid

Mineral oil

➤ Working Viscosity

In order for the optimum efficiency and service life, it is recommended to select the working viscosity (at working temperature) within the range below:

$$V_{opt} = \text{optimal working viscosity } 16 \dots 36 \text{ mm}^2/\text{s}$$

It is subject to the circuit temperature of a closed circuit and the reservoir temperature of an open circuit.

➤ Limit Viscosity

Limit viscosity:

$$V_{min} = 5 \text{ mm}^2/\text{s}$$

Short-term operation, permissible maximum temperature $t_{max} = +115^\circ\text{C}$

$$V_{max} = 1600 \text{ mm}^2/\text{s}$$

Short-term operation, cold start ($t_{min} = -40^\circ\text{C}$)

➤ Selection Diagram

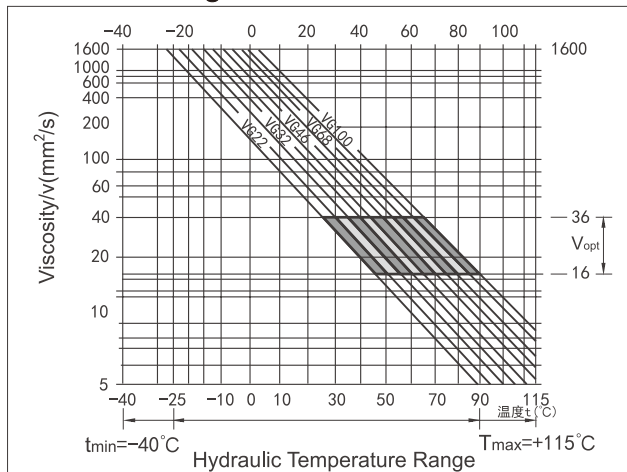

➤ Instructions on Selection of Hydraulic Fluid

The working temperature dependent on the ambient temperature is required for correct selection of hydraulic fluid. It refers to the circuit temperature of a closed circuit and the reservoir temperature of an open circuit.

The hydraulic fluid should be so selected that the working viscosity in the working range is within the optimum range (V_{opt} , the shaded area on the selection diagram). The higher viscosity is recommended under the same conditions.

For example: At an ambient temperature of $X^\circ\text{C}$, the working temperature of the circuit is 60°C . The viscosity within the optimum range (V_{opt} , shaded area) is VG46 or VG68 and the latter should be selected.

Note: The case drain temperature depends on the pressure and speed, and it is always higher than the circuit temperature. The temperature at any point within the system should not exceed $+115^\circ\text{C}$.

➤ Filtration

Finer filtration improves the cleanliness level of the hydraulic fluid, thus increasing the service life of the axial piston unit. To ensure normal operation of the axial piston unit, a cleanliness level of at least 9 according to NAS 1638 or 18/15 according to ISO/DIS 4406 is to be maintained.

When the hydraulic fluid has a high temperature, the cleanliness level should at least reach 8 according to NAS 1638 or 17/14 according to ISO/DIS 4406.

➤ Working Pressure Range

Maximum pressure at working port A or B:

	Shaft End A/Z	Shaft End B/P
Nominal pressure P_N	40MPa	35MPa
Maximum pressure P_{max}	45MPa	40MPa

➤ Flow Direction

CW rotation _____ A to B
 CCW rotation _____ B to A

➤ Speed Range

No limit to minimum speed n_{min} .

If uniformity of motion is required, n_{min} must not be less than 50 rpm.

See the operating parameters for the maximum speed.

➤ Case Drain Pressure

FKM shaft seal

The lower the speed and case drain pressure are, the longer the service life of the shaft seal is. The figure shows the permissible limit values of the shaft seal at intermittent pressure load. Do not exceed the values. Constant pressure within the case drain pressure limit will reduce life of the shaft seal.

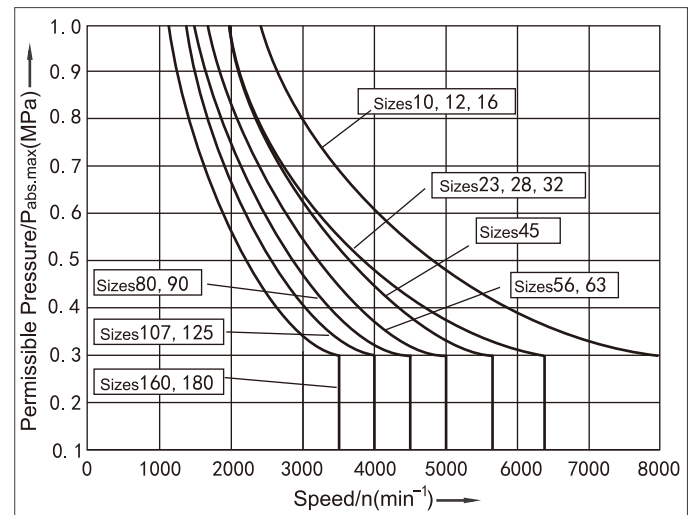



➤ Technical Data

Size				23	28	32	45	56	63
Displacement		$V_{g \max}$	mL/r	22.9	28.1	32.0	45.6	56.1	63.0
Maximum speed		n_{\max}	rpm	6300	6300	6300	5600	5000	5000
		$n_{\max}^{1)}$ Intermittent	rpm	6900	6900	6900	6200	5500	5500
Maximum flow	at n_{\max}	$q_{v \max}$	L/min	144	176	210	255	280	315
Equivalent torque Torque at		T_k	Nm/MPa	3.6	4.45	5.09	7.25	8.9	10.0
	$\Delta p=35\text{MPa}$	T	Nm	126	156	178	254	312	350
	$\Delta p=40\text{MPa}$	T	Nm	144	178	204	290	356	400
Case volume			L	0.20	0.20	0.20	0.33	0.45	0.45
Moment of inertia of drive shaft		J	kgm ²	0.0012	0.0012	0.0012	0.0024	0.0042	0.0042
Weight	HA2FM	M	kg	9.5	9.5	9.5	13.5	18	18
	HA2FE	M	kg	10.5	10.5	10.5	15	18	19
	HA2FMT	M	kg	-	10.7	-	-	-	-

Size				80	90	107	125	160	180
Displacement		$V_{g \max}$	mL/r	80.4	90.0	106.7	125	160.4	180.0
Maximum speed		n_{\max}	rpm	4500	4500	4000	4000	3600	3600
		$n_{\max}^{1)}$ Intermittent	rpm	5000	5000	4400	4400	4000	4000
Maximum flow	at n_{\max}	$q_{v \max}$	L/min	360	405	427	500	577	648
Equivalent torque Torque at		T_k	Nm/MPa	12.7	17.0	19.9	25.4	28.6	31.8
	$\Delta p=35\text{MPa}$	T	Nm	445	501	595	697	889	1001
	$\Delta p=40\text{MPa}$	T	Nm	508	572	680	796	1016	1144
Case volume			L	0.55	0.55	0.80	0.80	1.10	1.10
Moment of inertia of drive shaft		J	kgm ²	0.0072	0.0072	0.0116	0.0116	0.0220	0.0220
Weight	HA2FM	M	kg	23	23	32	32	45	45
	HA2FE	M	kg	23	25	34	36	47	47

1) : Intermittent maximum speed: overspeed for unloading and overhauling processing, $t < 5s$ and $\Delta p < 15\text{MPa}$

➤ Specification Calculation

Input flow	$q_v = \frac{V_g \cdot n}{1000 \cdot \eta_v}$	[L/min]	V_g = Displacement per revolution, mL/r
Torque	$T = \frac{V_g \cdot \Delta p \cdot \eta_{mh}}{20 \cdot \pi}$	[Nm]	Δp = Differential pressure, MPa
Power	$P = \frac{2\pi \cdot T \cdot n}{60000} = \frac{q_v \cdot \Delta p \cdot \eta_t}{600}$	[KW]	n = Speed, rpm
			η_v = Volumetric efficiency
			η_{mh} = Mechanical-hydraulic efficiency
			η_t = Total efficiency



► Installation Dimensions

HA2FM 23/28/32

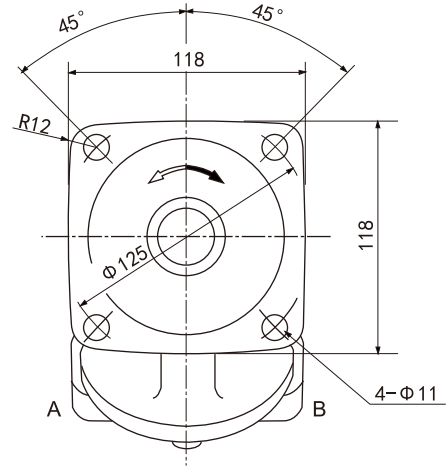
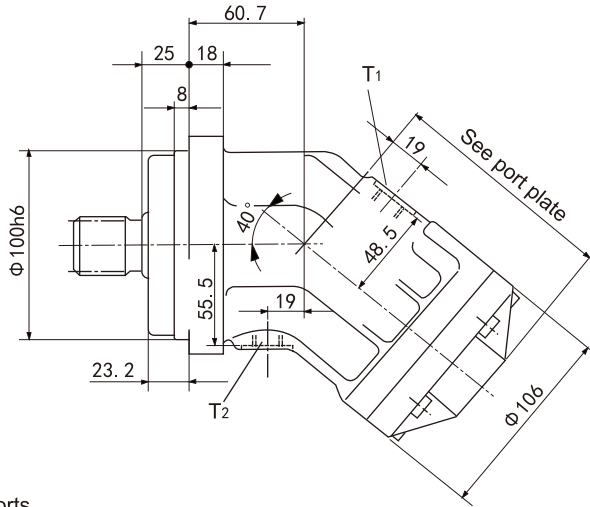

Ports
 A/B Working port (see port plate)
 T1/T2 Drain port (one plugged) M16x1.5

Port Plate

01 SAE flange, at rear

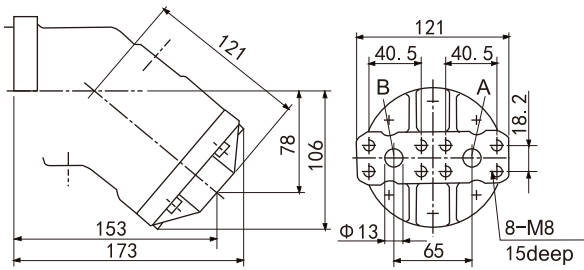

A/B Working port
 42MPa(6000 psi)high pressure series SAE 1/2"

02 SAE flange, at side

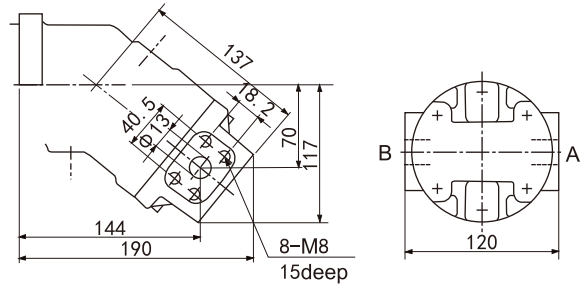

A/B Working port
 42MPa(6000 psi)high pressure series SAE 1/2"

03 Threaded port, at side

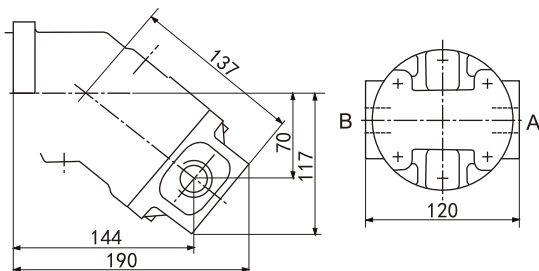

A/B Working port M27x2

04 Thread port, at side and rear

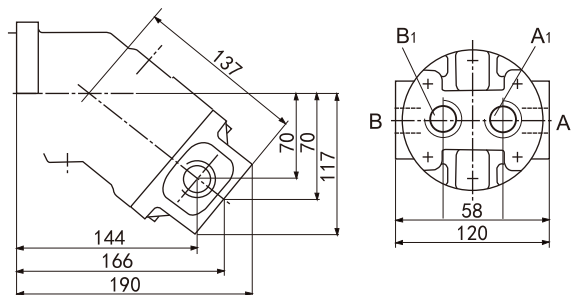

A/B/A1/B1 Working port M27x2



► Installation Dimensions

HA2FM 23/28/32

Drive shaft

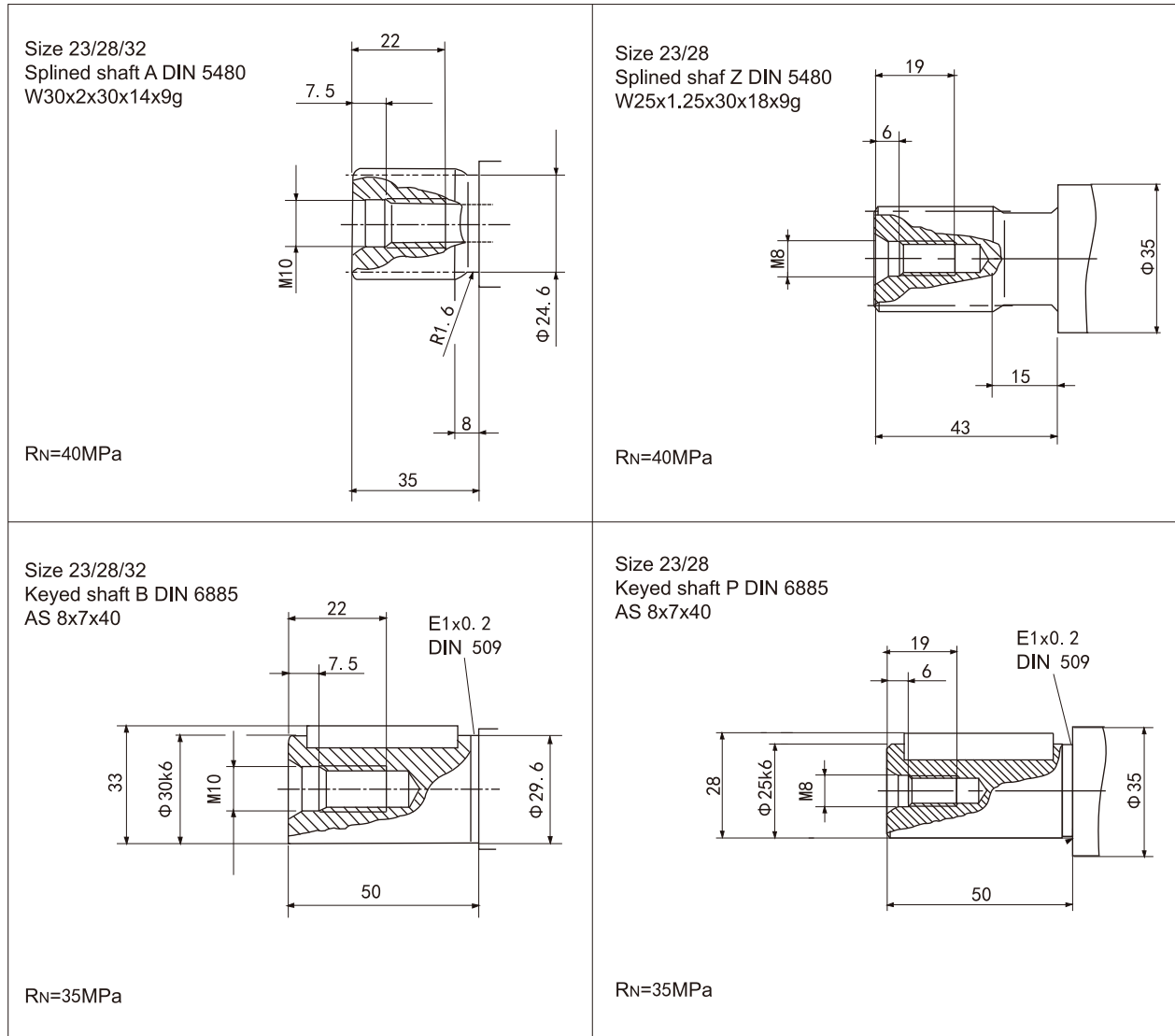



► Installation Dimensions

HA2FM 45

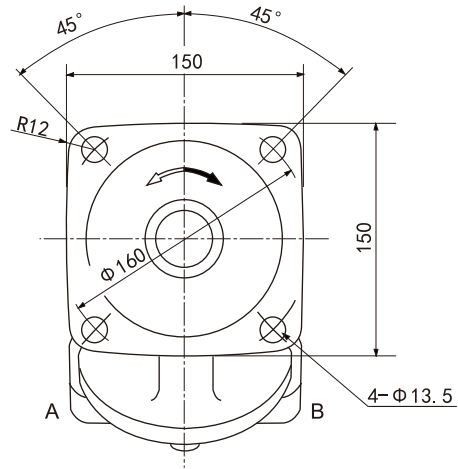
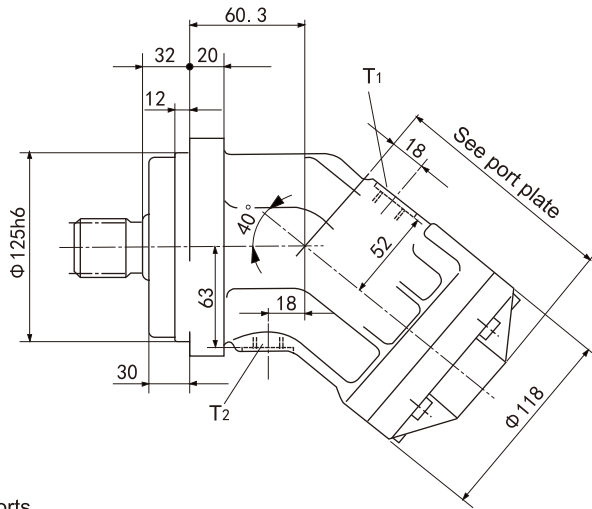

Ports
 A/B Working port (see port plate)
 T1/T2 Drain port (one plugged) M18x1.5

Port Plate

01 SAE flange, at rear

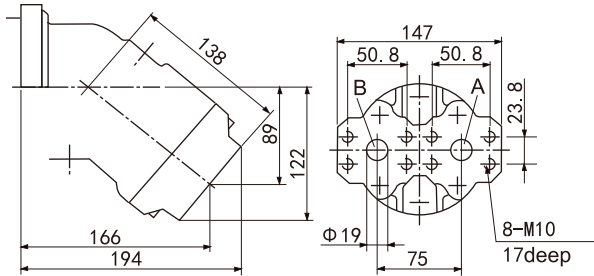

A/B Working port
 42MPa(6000 psi)high pressure series SAE 3/4"

02 SAE flange, at side

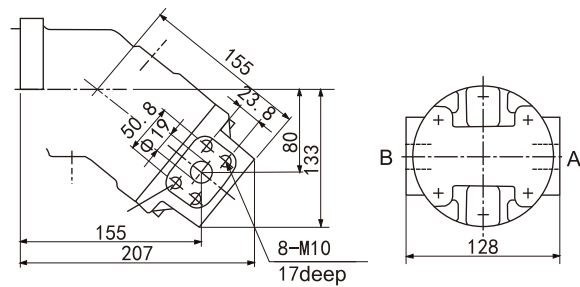

A/B Working port
 42MPa(6000 psi)high pressure series SAE 3/4"

04 Threaded port, at side and rear

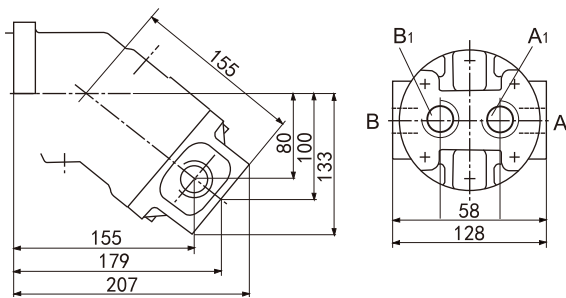

A/B/A1/B1 Working port M27x2

10 SAE flange port, at bottom

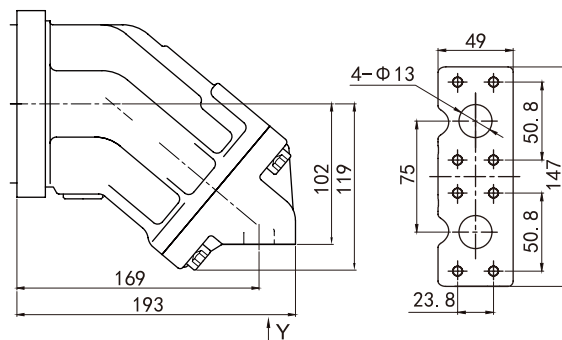

A/B Working port
 High pressure series,fastening thread DIN13
 M10x1.5,17deep SAE J518 3/4"



> Installation Dimensions

HA2FM 45

Drive shaft

Splined shaft A DIN 5480
W32x2x30x14x9g

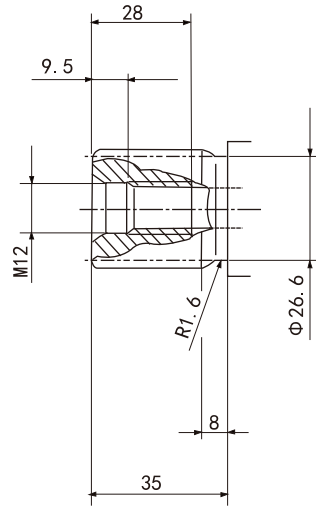

RN=40MPa

Splined shaft Z DIN 5480
W30x2x30x14x9g

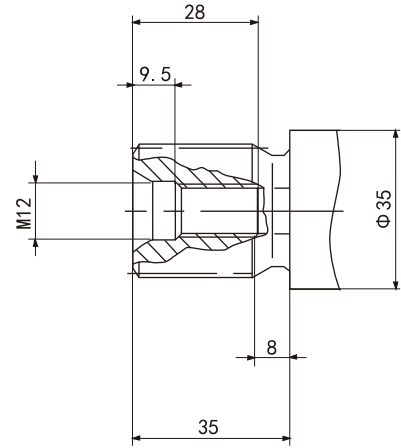

RN=40MPa

Keyed shaft P DIN 6885
AS 8x7x50

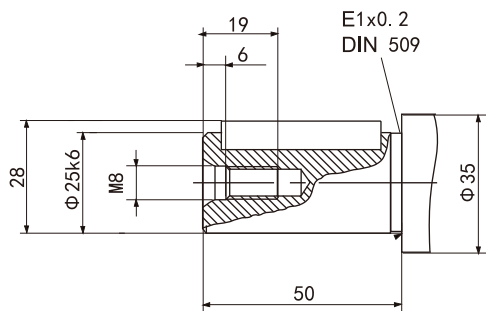

RN=35MPa



► Installation Dimensions

HA2FM 56/63

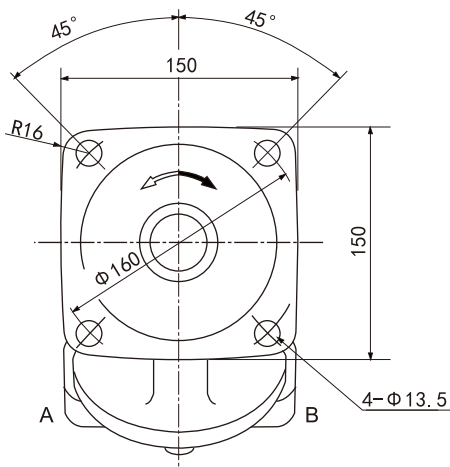
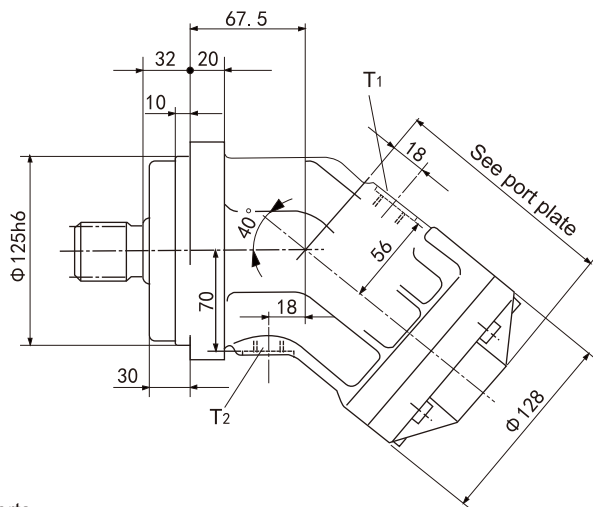

Ports
 A/B Working port (see port plate)
 T1/T2 Drain port (one plugged) M18x1.5

Port Plate

01 SAE flange, at rear

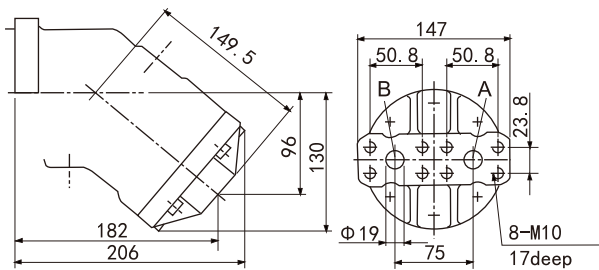

A/B Working port SAE 3/4"
 42MPa(6000 psi)high pressure series

02 SAE flange, at side

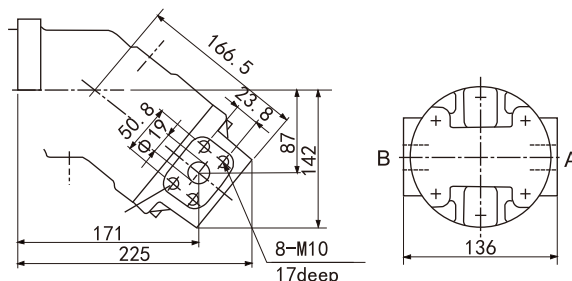

A/B Working port SAE 3/4"
 42MPa(6000 psi)high pressure series

04 Threaded port, at side and rear

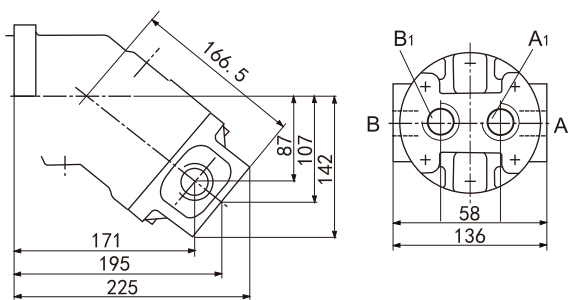

A/B/A1/B1 Working port M33x2

10 SAE flange port, at bottom

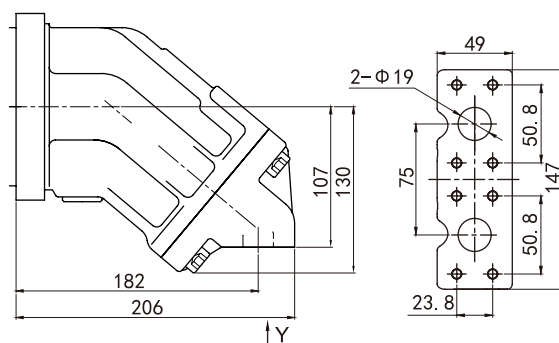

A/B Working port SAE J518 3/4"
 High pressure series,fastening thread DIN 13
 M10x1.5,17deep



Installation Dimensions

HA2FM 56/63	
Drive shaft	
<p>Size 56/63 Splined shaft A DIN 5480 W35x2x30x16x9g</p> <p>RN=40MPa</p>	<p>Size 56 Splined shaft Z DIN 5480 W30x2x30x14x9g</p> <p>RN=40MPa</p>
<p>Size 56/63 Keyed shaft B DIN 6885 AS 10x8x50</p> <p>RN=35MPa</p>	<p>Size 56 Keyed shaft P DIN 6885 AS 8x7x50</p> <p>RN=35MPa</p>



► Installation Dimensions

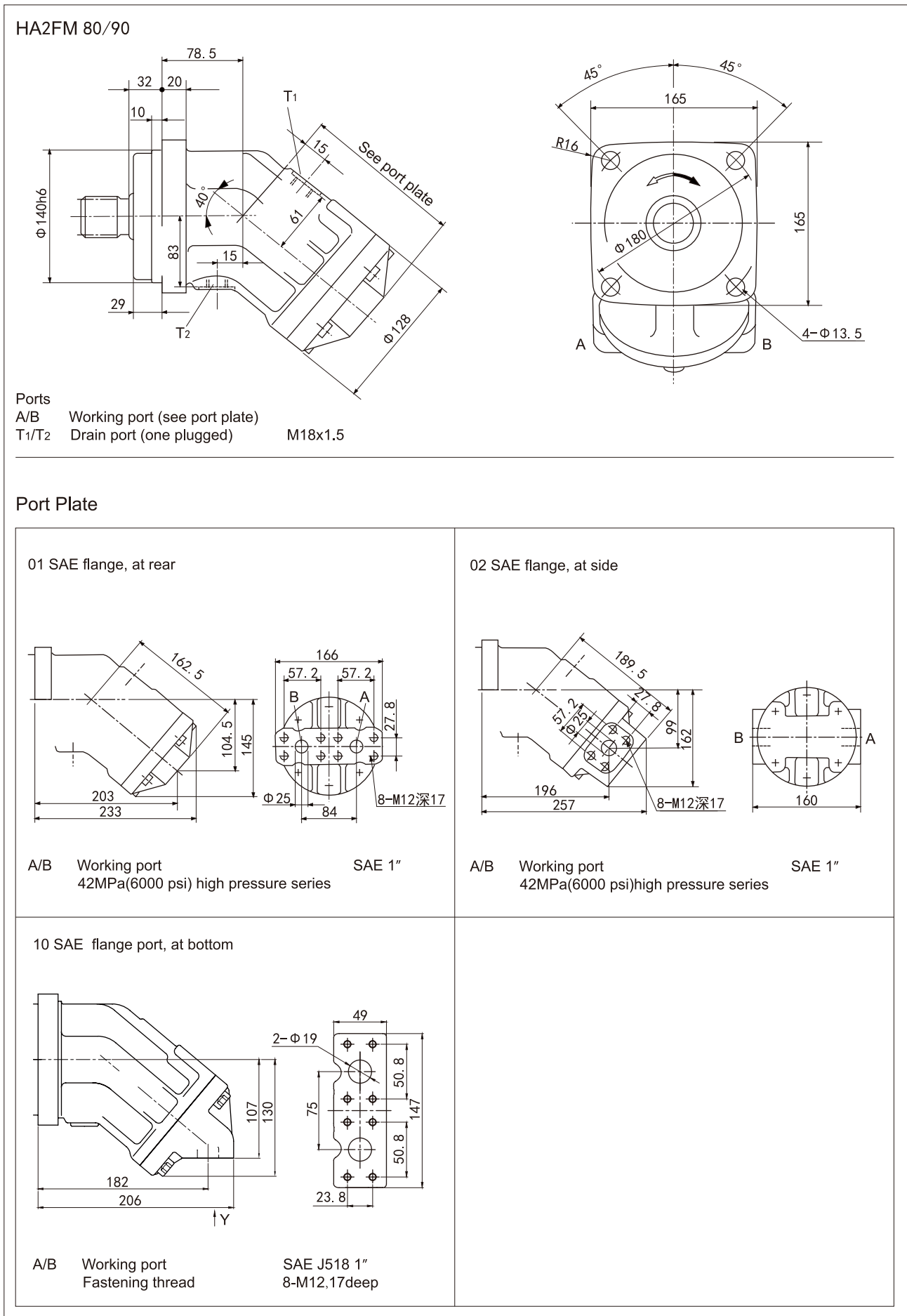



Installation Dimensions

HA2FM 80/90

Drive shaft

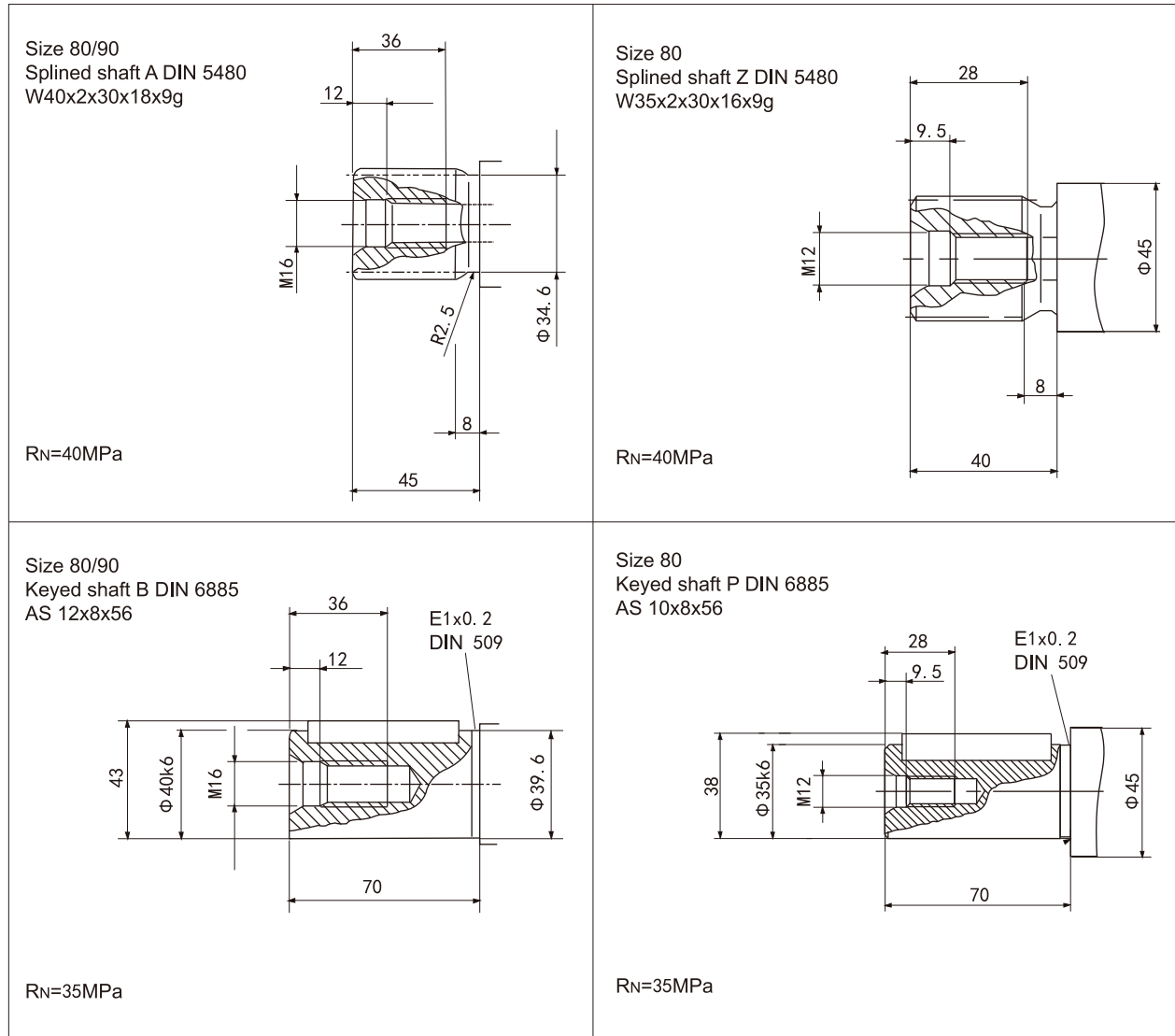



► Installation Dimensions

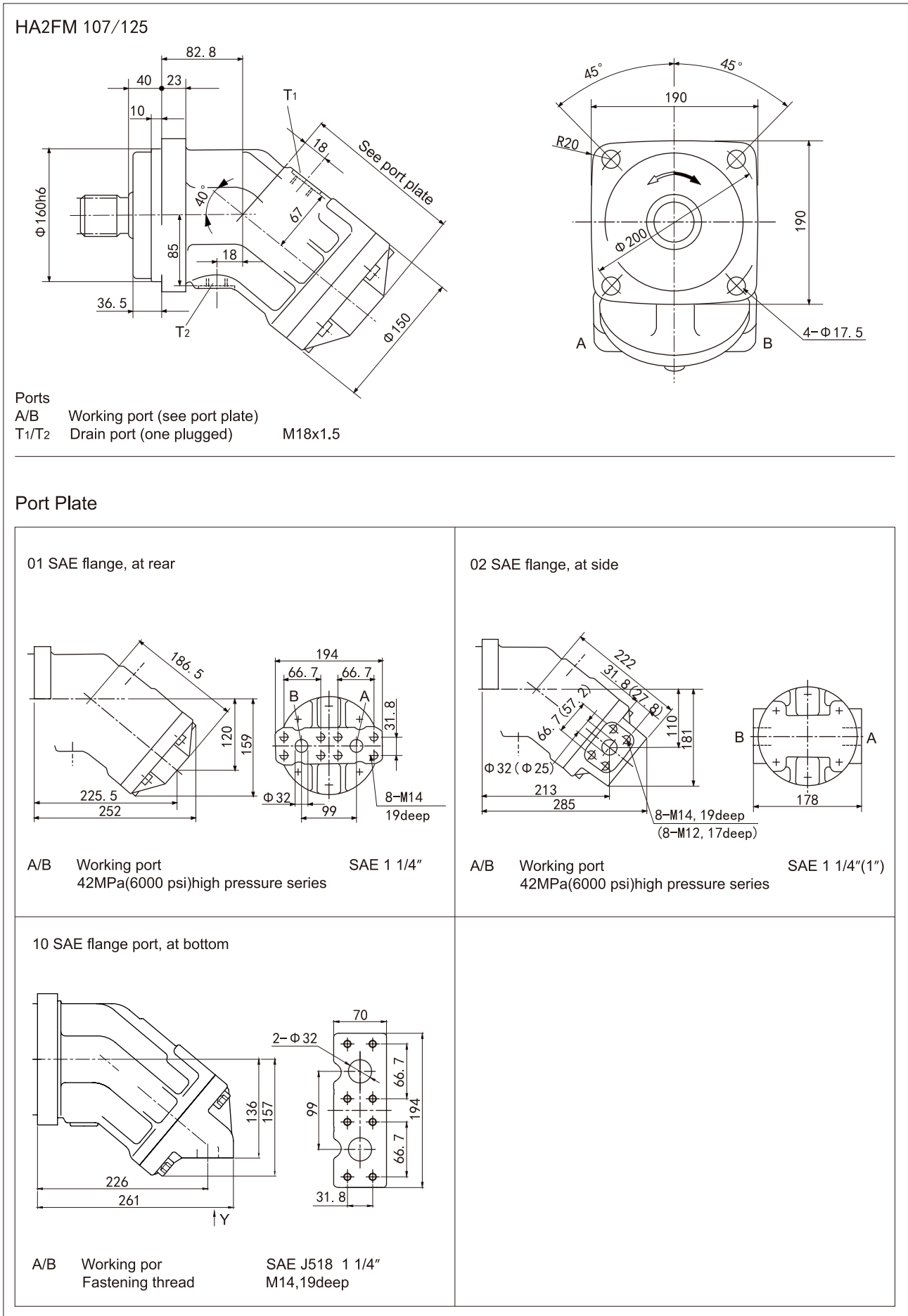

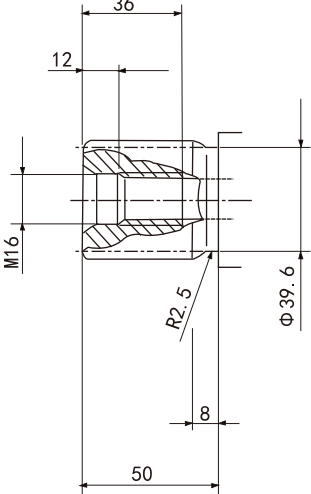
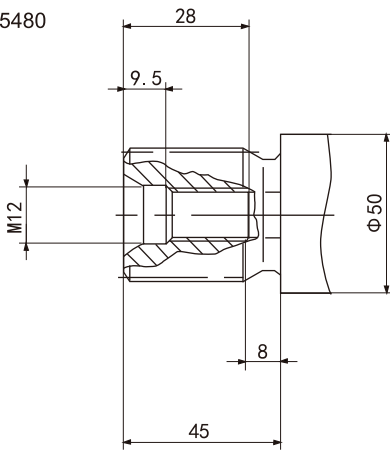
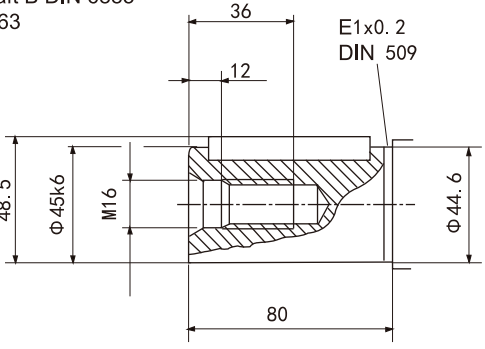
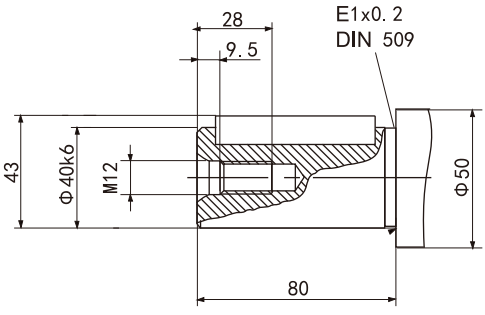

Installation Dimensions

<p>HA2FM 107/125</p>		
<p>Drive shaft</p>		
<p>Size 107/125 Splined shaft A DIN 5480 W45x2x30x21x9g</p>  <p>RN=40MPa</p>	<p>Size 107 Splined shaft Z DIN 5480 W40x2x30x18x9g</p>  <p>RN=40MPa</p>	
<p>Size 107/125 Keyed shaft B DIN 6885 AS 14x9x63</p>  <p>RN=35MPa</p>	<p>Size 107 Keyed shaft P DIN 6885 AS 12x8x63</p>  <p>RN=35MPa</p>	



► Installation Dimensions

HA2FM 160/180

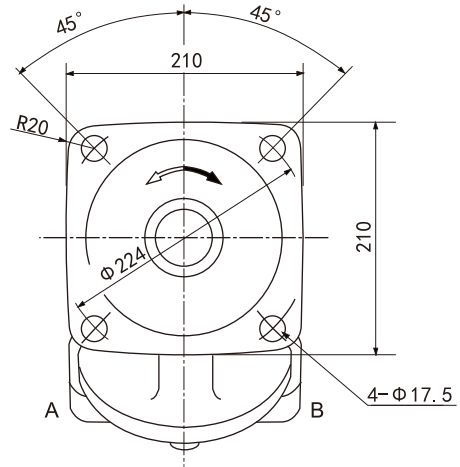
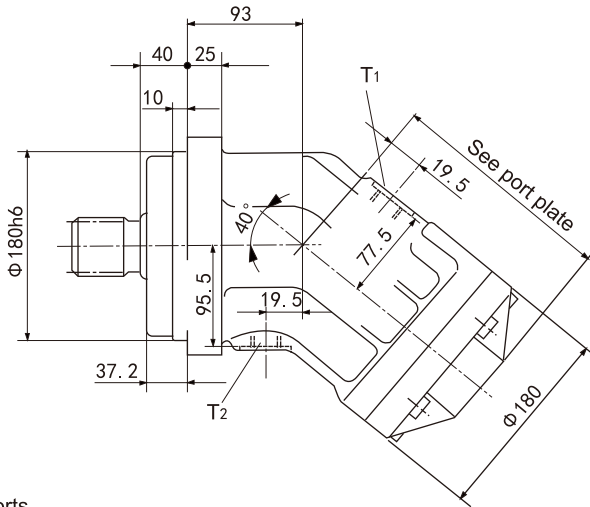

Ports
 A/B Working port (see port plate)
 T1/T2 Drain port (one plugged) M22x1.5

Port Plate

01 SAE flange, at rear

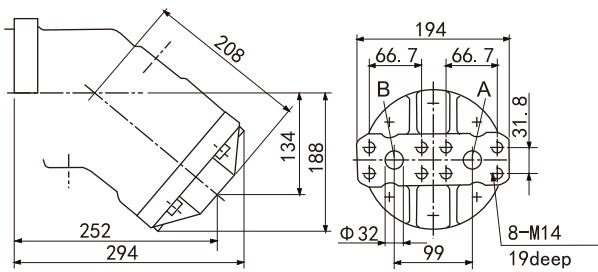

A/B Working port SAE 1 1/4"
 42MPa(6000 psi)high pressure series

02 SAE flange, at side

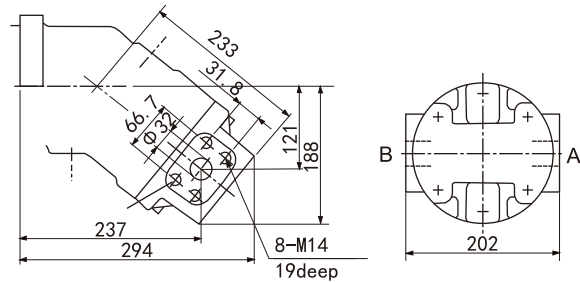

A/B Working port SAE 1 1/4"(1")
 42MPa(6000 psi)high pressure series

10 SAE flange port, at bottom

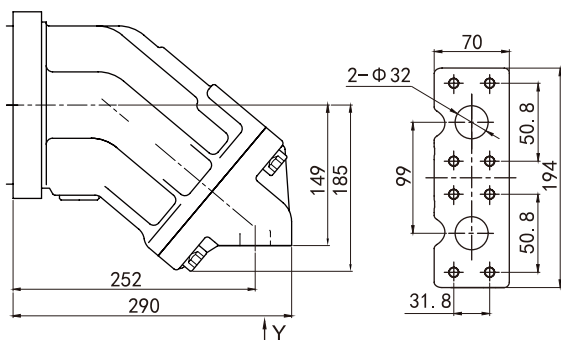

A/B Working port SAE J518 1 1/4"
 Fastening thread M14, 19deep



➤ Installation Dimensions

HA2FM 160/180

Drive shaft

Size 160/180
Splined shaft A DIN 5480
W50x2x30x24x9g

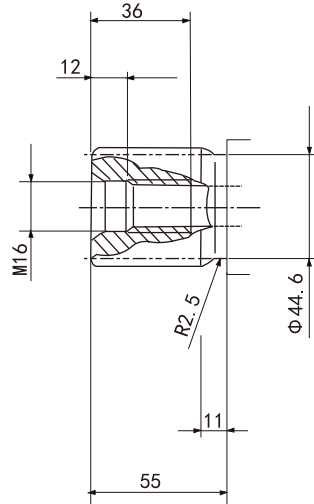

RN=40MPa

Size 160
Splined shaft Z DIN 5480
W45x2x30x21x9g

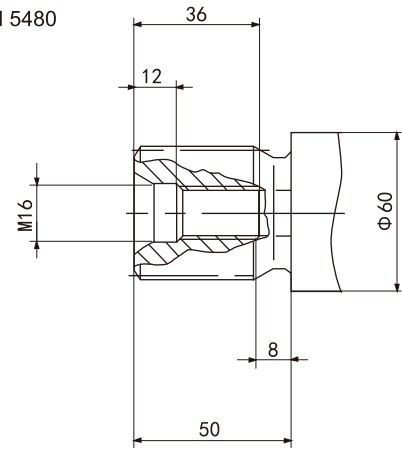

RN=40MPa

Size 160/180
Keyed shaft B DIN 6885
AS 14x9x70

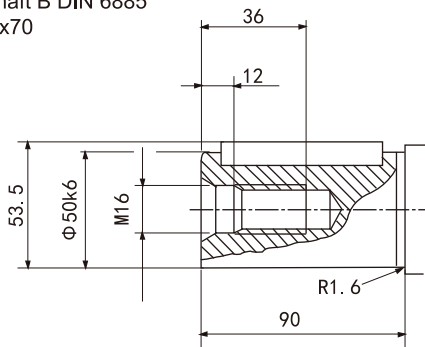

RN=35MPa

Size 160
Keyed shaft P DIN 6885
AS 14x9x70

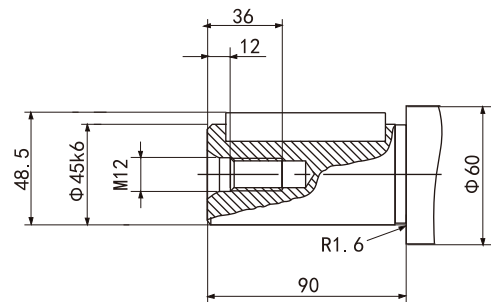

RN=35MPa



► Installation Dimensions

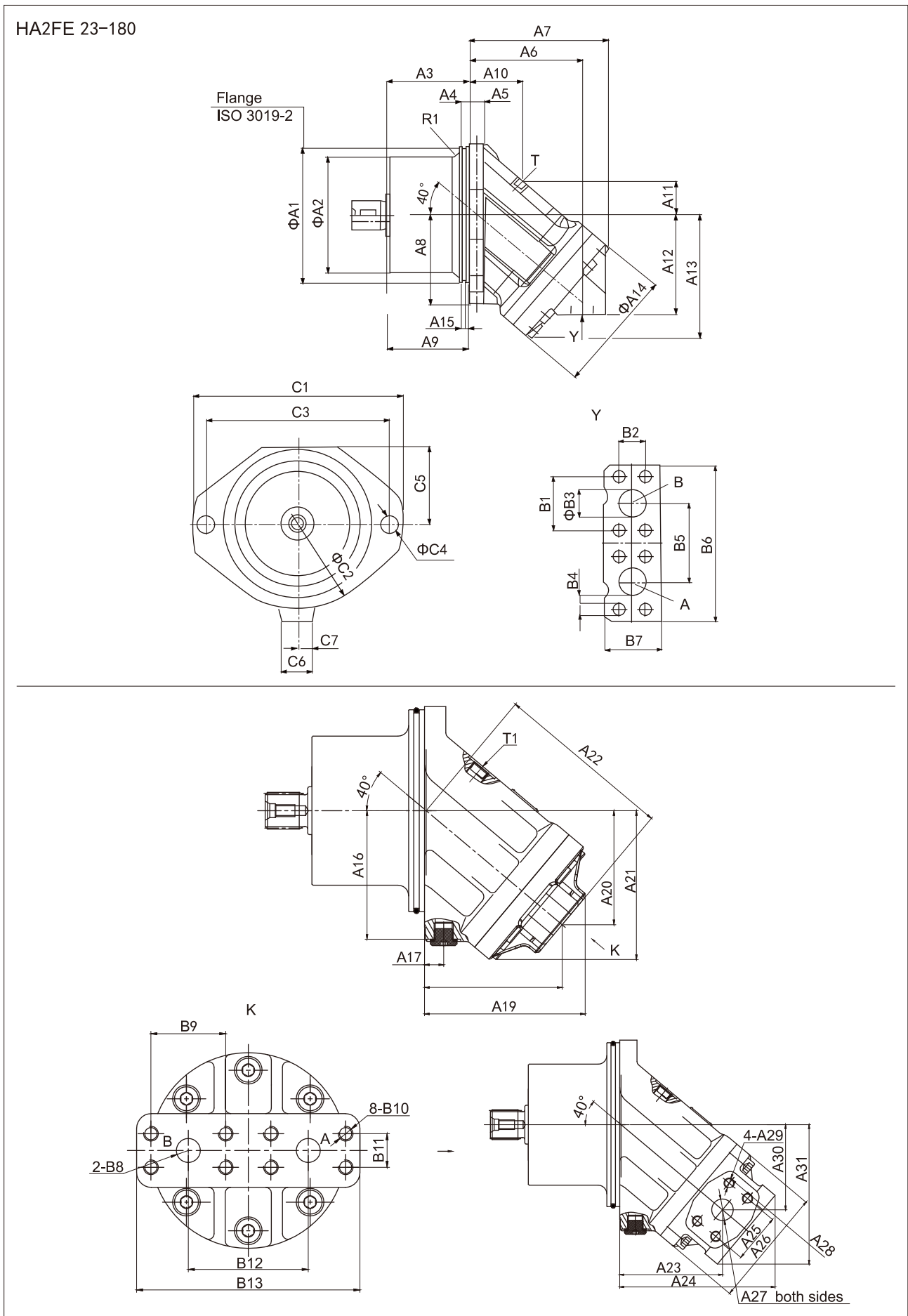



➤ Installation Dimensions

HA2FE 23-180

Size	Φ A1	Φ A2	A3	A4	A5	A6	A7	A8	A9	A10	A11	A12	A13	Φ A14	Φ A15
23/28/32	135 ⁰ _{-0.025}	94 ⁰ _{-0.5}	88.8	15	16	94	114	95	87.1	45	27	91	105	106	5.2
45	160 ⁰ _{-0.025}	117 ^{+1.5} ₋₂	92.3	15	18	109	133	106	90	50	31.3	102	119	118	5.2
56/63	160 ⁰ _{-0.025}	121 ⁰ _{-0.5}	92.3	15	18	122	146	109	90	59	34	107	128	128	5.2
80/90	190 ⁰ _{-0.029}	140.3 ⁰ _{-0.5}	110	15	20	127	157	123	106	54	41	120	144	138	5.2
107/125	200 ⁰ _{-0.029}	152.3 ⁰ _{-0.5}	122.8	15	20	143	178	135	119	58	41	136	158	150	5.2

Size	A16	A17	A18	A19	A20	A21	A22	A23	A24	A25	Φ A26	Φ A27	A28	A29	A30
45	104.5	20	-	-	-	-	-	109.2	160.4	50.8	118	19	23.8	M10, 17deep	78.7
56/63	104.5	20	-	-	-	-	-	129.7	186.3	50.8	128	20	23.8	M10, 17deep	92.5
80/90	121	18	126	156	104.5	145	162.5	119	180	57.2	138	25	27.8	M12, 17deep	99
107/125	135	22	-	-	-	-	-	130	202	66.7	150	32	31.8	M14, 19deep	109.6

Size	R1	O-ring	B1	B2	Φ B3	B4	B5	B6	B7	Port A/B	Drain Port T
23/28/32	10	126*4	40.5	18.2	13	M8, 15deep	59	115	40	1/2 in	M16*1.5, 12deep
45	10	150*4	50.8	23.8	19	M10, 17deep	75	147	49	3/4 in	M18*1.5, 12deep
56/63	10	150*4	50.8	23.8	19	M10, 17deep	75	147	48	3/4 in	M18*1.5, 12deep
80/90	10	180*4	57.2	27.8	25	M12, 17deep	84	166	60	1 in	M18*1.5, 12deep
107/125	16	192*4	66.7	31.8	32	M14, 19deep	99	194	70	1 1/4 in	M18*1.5, 12deep

Size	Φ B8	B9	B10	B11	B12	B13	C1	C2	C3	C4	C5	C6	C7
23/28/32	-	-	-	-	-	-	188	154	160	14	71	42	13
45	-	-	-	-	-	-	235	190	200	18	82	47.5	15
56/63	-	-	-	-	-	-	235	190	200	18	82	36	0
80/90	25	57.2	M12, 17deep	27.8	84	166	260	220	224	22	98	40	0
107/125	-	-	-	-	-	-	286	232	250	22	103	40	0

➤ Drive shaft

Size	Splined Shaft(DIN 5480)	W1	W2	W3	W4	W5	W6
23/28/32	A W30*2*30*14*9g	M10	7.5	22	35	8	35
23/28	Z W25*1.25*30*18*9g	M8	6	19	35	15	43
45	Z W*30*2*30*14*9g	M12	9.5	28	35	8	35
56/63	A W35*2*30*16*9g	M12	9.5	28	40	8	40
56	Z W30*2*30*14*9g	M12	9.5	28	40	8	35
80/90	A W40*2*30*18*9g	M16	12	36	45	8	45
80	Z W35*2*30*16*9g	M12	9.5	28	45	8	40
107/125	A W45*2*30*21*9g	M16	12	36	50	8	50
107	Z W40*2*30*18*9g	M12	9.5	28	50	8	45

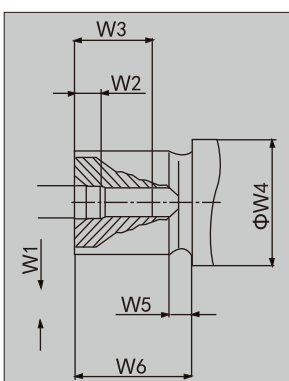



➤ Flushing and Boost-pressure Valve

Overview

The flushing valve is used to prevent over-temperature. The minimum boost pressure must be guaranteed for flushing of a closed circuit.

Hydraulic fluid from the low-pressure side is directed into the motor housing. Then, it is fed into the reservoir together with the case drain fluid. The hydraulic fluid removed out of the circuit must be replaced by that from the boost-pressure valve.

Cracking pressure (1.6 MPa, fixed setting) of the boost-pressure valve must be considered when setting the boost pressure of the pump in a closed circuit.

Standard flow

At low pressure $\Delta p=2.5\text{MPa}$

Size	Flushing Flow
23/28/32/45/56/63	3.5L/min
80/90	5L/min
107/125	8L/min
160/180	10L/min

Orifices can be used to adjust the flow as necessary. If nonstandard flows are required, please specify the required throttle valve when ordering.

Circuit diagram

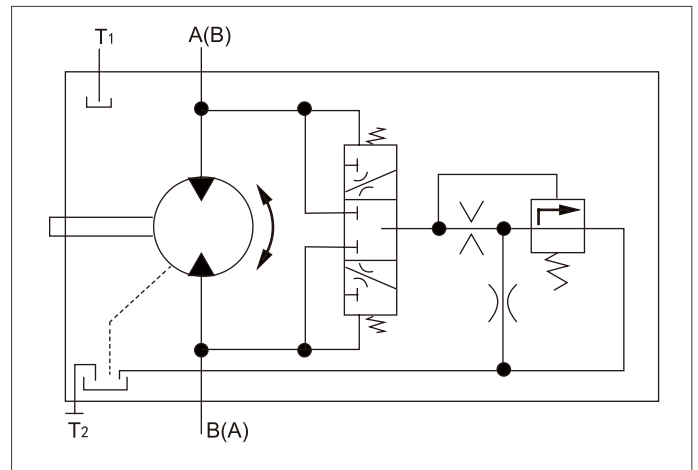

Port Plate

027: SAE flange ports, at side

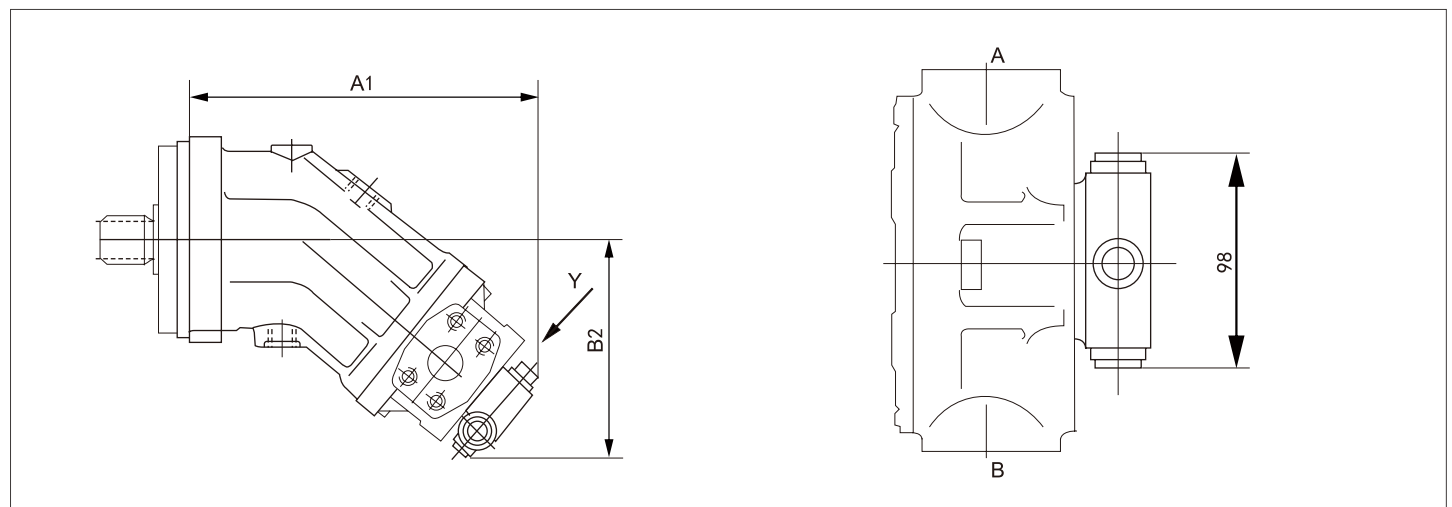

Size	A1	B2
23/28/32	196	138
45	223	151
56/63	239	159
80/90	268	173.5
107/125	294	192
160/180	315	201



➤ Flushing and Boost-pressure Valve

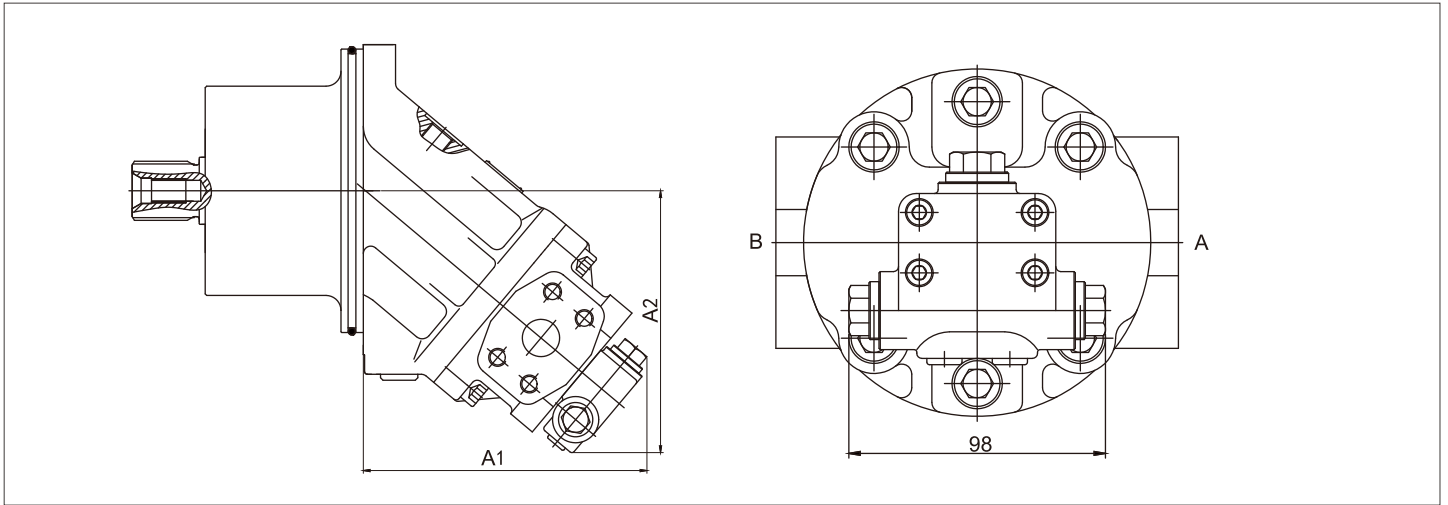

Size	A1	B2
45	151	148.5
56/63	167	156
80/90	190	173.5
107/125	211	192



Pressure Relief Valve

Overview

The pressure relief valve prevents overload of the hydraulic motor. Once it reaches the set cracking pressure, the hydraulic fluid flows from the high-pressure side to the low-pressure side. The pressure relief valve can only be used in combination with port plates 181 and 191. (The counterbalance valve is to be installed to the port plate 181. See the page below.)

Setting range of cracking pressure _____ 50-420 bar
Please specify in plain text the cracking pressure of the pressure relief valve when ordering.

Circuit diagram

Make sure to ask for the installation diagram before completion of the final design. Dimensions in mm.

Version without pressure boost facility, "191"

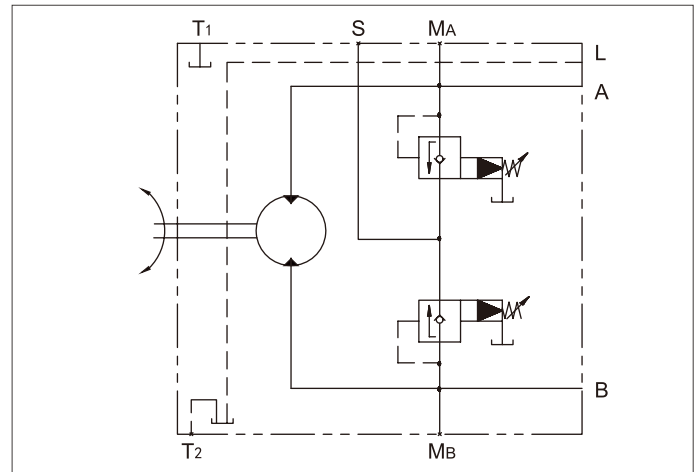

Installation Dimensions

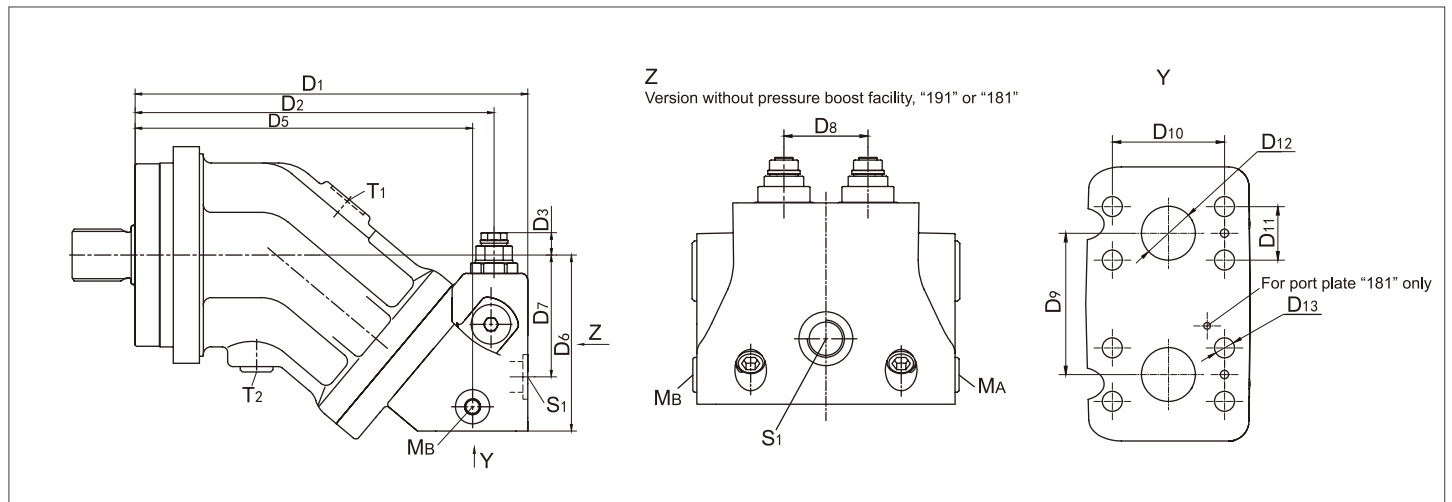

Size	D1	D2	D3	D4	D5	D6	D8	D9	D10	D11	D12	D13
80/90	271	243	17.5	59	229	134	42	75	57.2	27.8	Φ 25	M12, 18deep

Size	A/B	S1	MA, MB1)	Pst1)
80/90	1 in	M26*1.5, 16deep	M26*1.5, 16deep	G 1/4



Counterbalance Valve BVD

Function

Counterbalance valves for travel drives/winches are designed to reduce the danger of overspeed and cavitation of axial piston motors in open circuits. Cavitation occurs if, during brake, when going downhill or during load lowering process, the motor speed is greater than that at the given inlet flow.

If the inlet pressure falls, the counterbalance spool moves to throttle the return flow and brake the motor until the inlet pressure returns to approx 20 bar.

Note

-The counterbalance valve cannot replace the mechanical service brake and holding brake.

-For the design of the brake release device, we must know the following data for the mechanical holding brake:

The cracking pressure

The volume of the counterbalance spool between the minimum stroke (brake closed) and maximum stroke (brake released with 21 bar)

The required closing time for warming up (oil viscosity at approx 15 mm²/s)

Circuit diagram

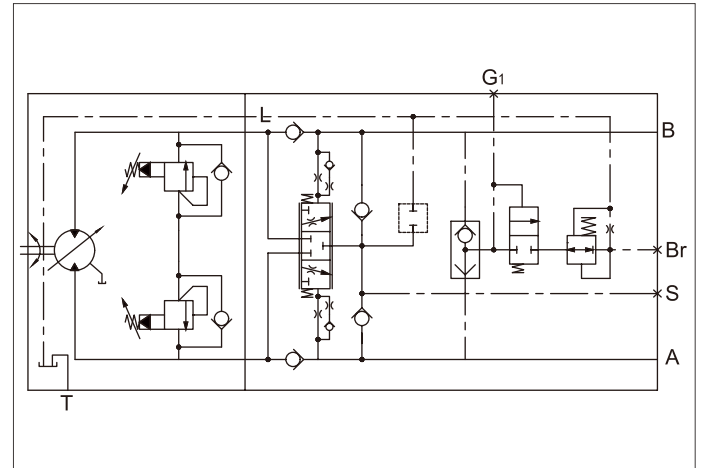

Installation Dimensions-HA2FM

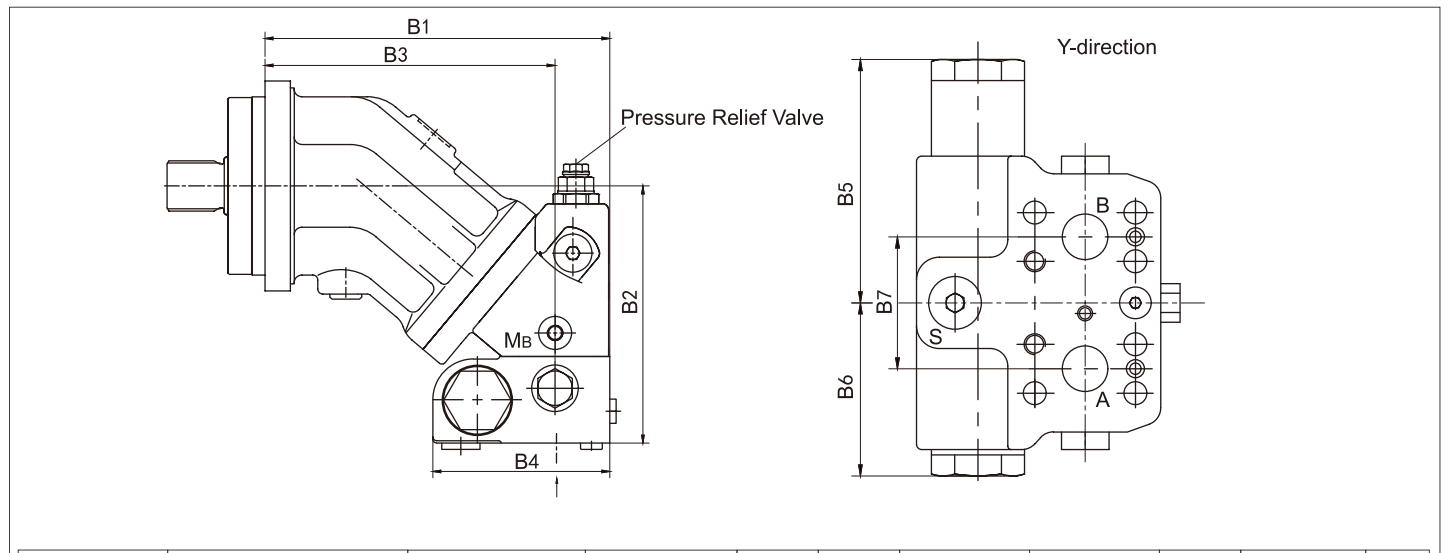

Size	Counterbalance Valve	Port A/B	Dimension B1	B2	B3	B4 (S)	B4 (L)	B5	B6	B7
80/90	BVD20. . 27	1 in	271	207	229	142	147	139	98	75
107/125	BVD20. . 28	1 in	298	238	251	142	147	139	98	84
107/125	BVD25. . 38	1 1/4 in	298	239	251	158	163	175	120.5	84
160/180	BVD25. . 38	1 1/4 in	332	260	285	158	163	175	120.5	84



➤ Counterbalance Valve BVD

Installation Dimensions-HA2FE

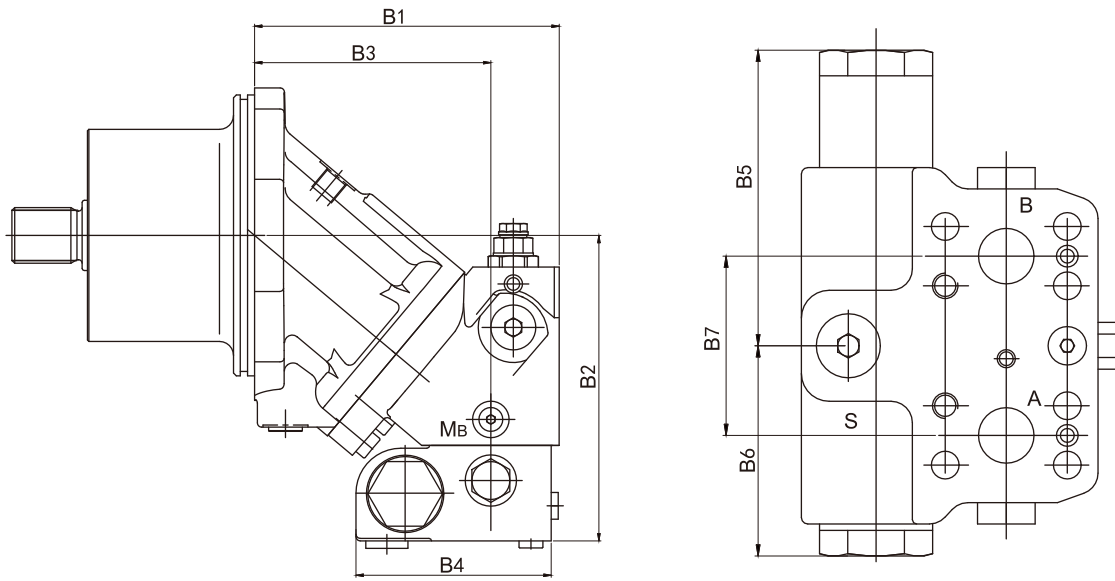

Size	Counterbalance Valve	Port A/B	Dimension B1	B2	B3	B4 (S)	B4 (L)	B5	B6	B7
80/90	BVD20 . . 27	1 in	193	207	151	142	147	139	98	75
107/125	BVD20 . . 28	1 in	216	238	168	142	147	139	98	84
107/125	BVD25 . . 38	1 1/4 in	216	239	168	158	163	175	120.5	84
160/180	BVD25 . . 38	1 1/4 in	249	260	202	158	163	175	120.5	84

Ports

Name	Usage	Product	Standard	Size ¹⁾	Max. Pressure(bar) ²⁾	State ⁴⁾
A/B	Service line		SAE J518	See table above	420	O
S	Boost port	BVD 20 BVD 25	DIN 3852 ³⁾ DIN 3852	M22*1.5, 14deep M27*1.5, 16deep	30 30	X
Br	Brake release port, reduced high pressure	L	DIN 3852 ³⁾	M12*1.5, 12.5deep	30	X
Gmt	Brake release port, high pressure	S	DIN 3852 ³⁾	M12*1.5, 12.5deep	420	X
MA/MB	Measuring port pressure A/B		ISO 6149 ³⁾	M12*1.5, 12deep	420	X

¹⁾ : See safety instructions for the maximum tightening torque.

²⁾ : Depending on the application, momentary pressure peaks may occur. Keep this in mind when selecting measuring devices and fittings.

³⁾ : The countersink may be deeper than specified in the standard.

⁴⁾ : O=must be connected (plugged on delivery) X=plugged (in normal operation)



➤ Counterbalance Valve BVD

Mounting the counterbalance valve

The counterbalance valve is fastened to the motor with two set screws (transport lock) on delivery. The set screws may not be removed when mounting the working lines. If the counterbalance valve and the motor are delivered separately, the counterbalance valve must first be fastened to the motor port plate with the supplied set screws. The counterbalance valve is finally mounted to the motor by fitting the SAE flange.

6 Screws(1,2,3,4,5,8) _____ Length $B_1+B_2+B_3$
 2 Screws(6,7) _____ Length B_3+B_4

Screw	Strength Grade	Tightening Torque(Nm)
M6*1 (set screw)	10.9	15.5
M10	10.9	75
M12	10.9	130
M14	10.9	205

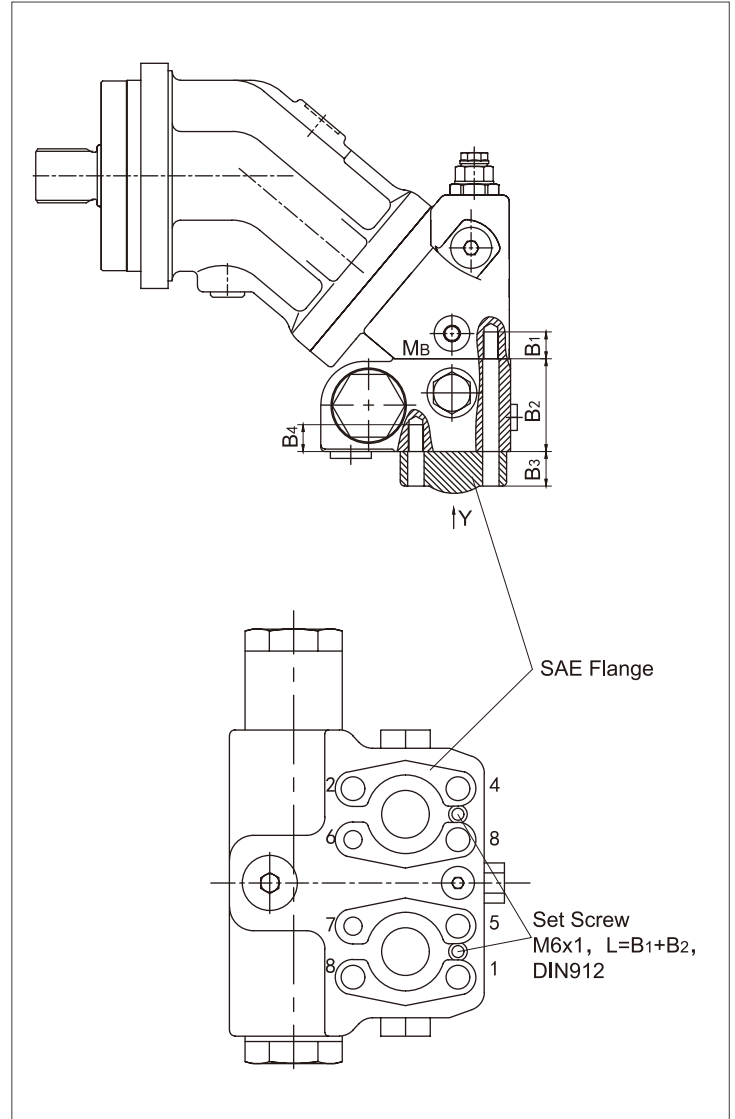

Tighten the screws in turn (from 1 to 8) in two steps (see the diagram on the right).

Step 1: Tighten the screws to a half of the tightening torque.

Step 2: Tighten the screws to the maximum tightening torque (see the table below).

Size	28/32/45	56/63	80/90	107/125/160/180	107/125
Port plate	18				
B1 ¹⁾	M10*1.5, 17deep	M10*1.5, 17deep	M12*1.75, 18deep	M14*2, 19deep	M12*1.75, 17deep
B2	78 ²⁾	68	68	85	68
B3	Applicable to specific customers				
B4	M10*1.5, 15deep	M10*1.5, 15deep	M12*1.75, 16deep	M14*2, 19deep	M12*1.75, 17deep

1) : Minimum required threads:1*Φthread

2) : Sandwich plate valve included



► Installation and Commissioning Instructions-HA2FM

Installation of counterbalance valve

The motor must be filled with hydraulic fluid during startup and commissioning. The motor should be started at low speed under no load until air in the system is thoroughly bled.

The hydraulic fluid in the housing leaks through the working lines after a longer standstill.

Therefore, make sure the housing is filled with hydraulic fluid before restart. The leakage should be directed to the reservoir via the highest drain port of the housing.

Installation position

Any position you prefer. For installation position "drive shaft upwards", use motor with air bleed port R.

Above-reservoir installation

Above-reservoir installation means that the motor is installed above the minimum fluid level of the reservoir.

–The procedure is the same as that for below-reservoir installation.

–Installation positions 1 and 2:

The hydraulic fluid in the housing may leak via the working lines and air may come inside (through the shaft seal) in the case of a longer standstill. The bearings may not be properly lubricated at restart. Hence, hydraulic fluid must be filled via the highest drain port before restart.

–Installation position 2 (drive shaft upwards)

The bearings are not sufficiently lubricated in this position as long as the housing is not filled with hydraulic fluid. Insert a check valve (0.05 MPa cracking pressure) in the drain line to prevent overflow of hydraulic fluid from the drain port.

Below-reservoir installation

The motor is installed below the minimum fluid level of the reservoir. (standard)

–Fill the axial piston motor with hydraulic fluid via the highest drain port before startup.

–For the shaft upwards installation position, make sure to fully fill the motor housing before startup. Air bubbles at bearings will cause damage to the axial piston unit.

–Run the motor at low speed (initial speed) until the entire circuit is filled with hydraulic fluid.

–Minimum immersion depth of suction line and drain line in reservoir: 200 mm (from the minimum fluid level of the reservoir).

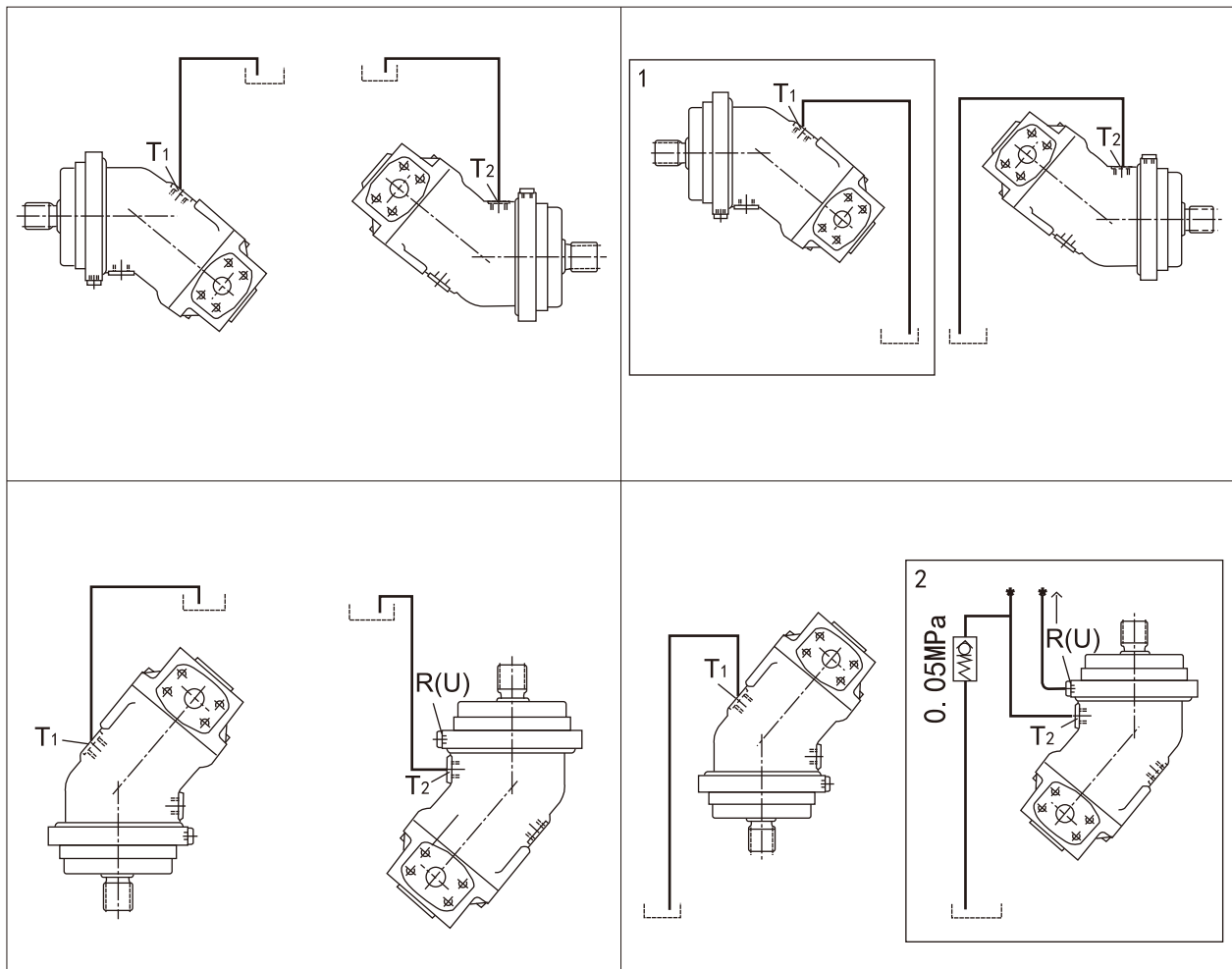



> Installation and Commissioning Instructions-HA2FE

Overview

The motor (housing) must be filled with hydraulic fluid during startup and commissioning.

The motor should be started at low speed under no load until air in the system is thoroughly bled.

The hydraulic fluid in the housing leaks through the working lines after a longer standstill. Make sure the housing is filled with hydraulic fluid before restart.

The leakage should be directed to the reservoir via the highest drain port of the housing.

Installation position

Shaft horizontal or vertically downward.

Top installation

The motor is installed below the minimum fluid level of the reservoir. (standard)

-Fill the axial piston motor with hydraulic fluid via the highest drain port before startup.

-Run the motor at low speed until the entire circuit is filled with hydraulic fluid. (Bleed the air via working ports A and B if the lines are long).

-Minimum immersion depth of drain line in reservoir: 200 mm (from the minimum fluid level of the reservoir).

Bottom installation

The motor is installed above the minimum fluid level of the reservoir.

-The procedure is the same as that for top installation.

-Additional measures for installation position 1:

The hydraulic fluid in the housing may leak via the working lines (and air may come inside through the shaft seal) in the case of a longer standstill.

The bearings may not be properly lubricated at restart. Hence, hydraulic fluid must be filled via the highest drain port before restart.

-“Shaft horizontal” installation position:

The working lines must not face upward if the installation position is above the reservoir.

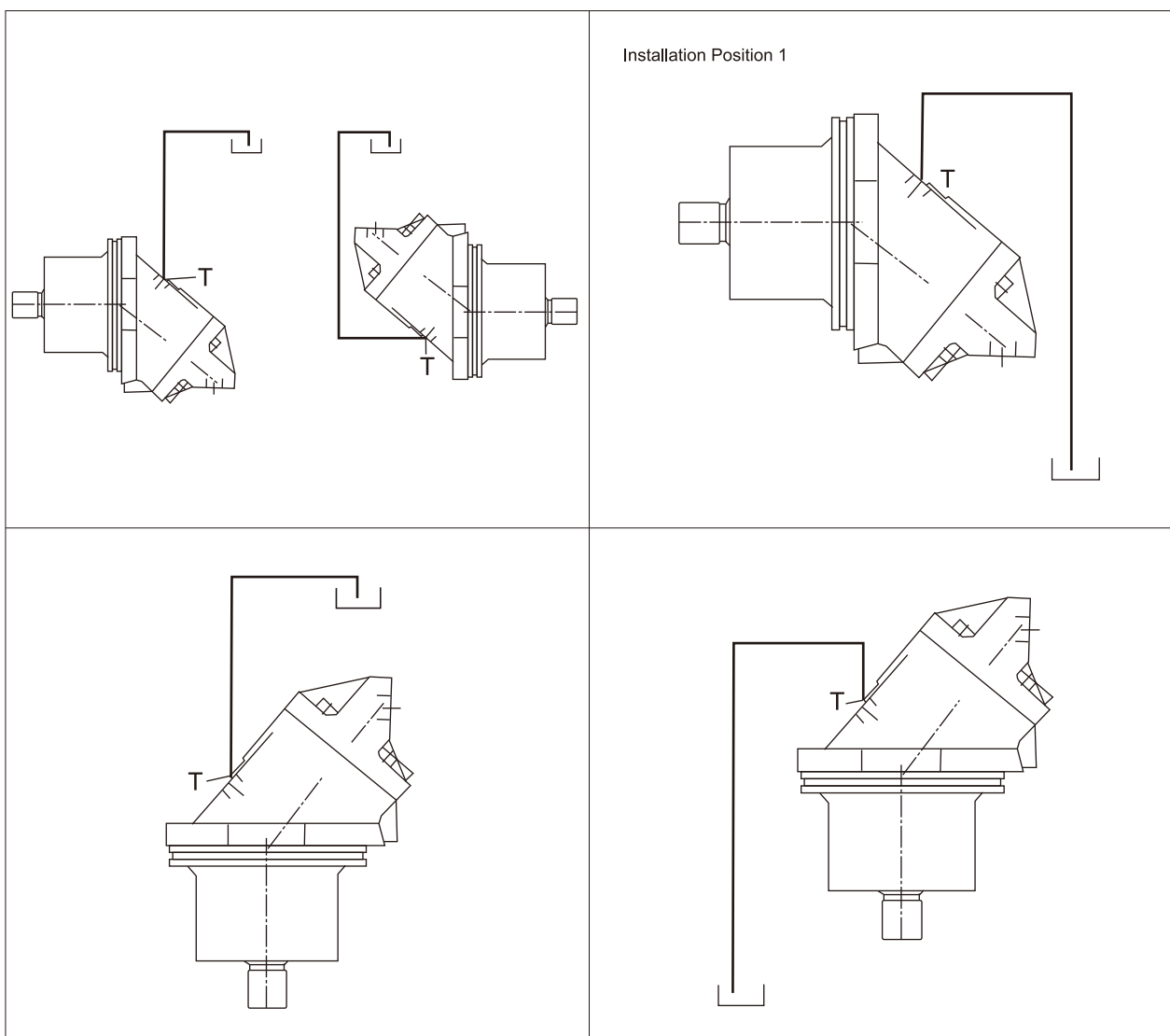





Since 2002

Over twenty years of deep cultivation in the field of hydraulic Solutions

HYTEK is a high technology enterprise integrating R&D, production, sales and service of hydraulic power products. Provides professional hydraulic transmission control products and solutions for construction machinery, road machinery, material handling machinery, agricultural and forestry machinery, industrial equipment and other fields. After more than 20 years of continuous R&D, technological innovation, market development and application services, technical level and the scale of production and sales have been on the forefront of the industry. Hytek has been committed to helping the development of subdivided industries with innovative hydraulic technology, "focusing on the challenges and pressures of customers, providing competitive products and solutions, reducing costs and increasing efficiency for customers, and continuously creating maximum value".

Product Series

- Open Circuit Pump
- Closed Circuit Pump
- Fixed Displacement Motor
- Variable Displacement Motor
- Hydrostatic Transmission Unit
- Internal Gear Pump
- Vane Pump
- Proportional valve/
Industrial Hydraulic Valve

For more information,
please visit our official website and social media:en.hytek.cn



@Hytek Power

HYTEK POWER CO.,LTD.

No. 99, Shengyuan Road, Tengqiao Town, Lucheng District, Wenzhou City 325029, Zhejiang, CHINA
Email: globalsales@hytek.cn

America Canada Germany Italy Russia Türkiye Australia South Korea Thailand India Indonesia South Africa

HYTEK-REV1.0 04/2026

If there are any other modifications, no further notice will be given.