



Axial Piston Variable Pump HA4VTG Series 39

Size: 71/80/90/100 mL/r
Rated pressure: 40 MPa
Max.pressure: 45 MPa



Features



- Axial piston variable pump with swashplate design for hydraulic transmission in closed circuits
- Flow directly proportional to drive speed and displacement can realize stepless speed regulation
- Increase of output flow from zero to the maximum value along with the swivel angle of the swashplate
- Smooth change in flow direction when the swashplate passes the neutral position
- Multiple compatible control valves realize various control and adjustment functions
- Cartridge type high pressure relief valve protects the pump and the motor against overload
- Built-in auxiliary pump featuring small size and high efficiency serves as the boost and control pump
- Cartridge type boost-pressure relief valve limits the maximum boost pressure
- Optional built-in pressure cutoff and filter

Contents



● Model Code.....	02
● Structure.....	06
● Hydraulic Schematic Diagram.....	06
● Technical Data.....	08
● HW Mechanical Servo Control.....	10
● HD Pilot Pressure Control.....	12
● EP Electric Control with Proportional Solenoid.....	13
● EZ Electric Control with Switching Solenoid.....	14
● Connector for Solenoids.....	15
● High Pressure Relief Valve.....	16
● Pressure Cut-off,D.....	17
● Filter.....	18
● Installation Dimensions.....	20
● Installation Instructions.....	30



	c	A	B	C	D	E	F	G		I	K		M	N	P	R	S	T	U	X		Z	
HA4VT	G							/	39		-											-	

Axial Piston Unit

-	Swashplate design, variable closed circuits	HA4VT
---	---	-------

Operation

c		71	80	90	100	
	Closed circuit	●	●	●	●	G

Displacement

A	Geometric displacement, in mL/r	71	80	90	100	
---	---------------------------------	----	----	----	-----	--

Variable Control Method

B	Hydraulic control	Pilot pressure control	Without inlet filtration		71	80	90	100		
			With inlet filtration		●	●	●	●	HD1	
		Mechanical servo		●	●	●	●	HW		
	Electric control	With proportional solenoid	Without inlet filtration	U=12V DC		●	●	●	●	EP1
				U=24V DC		●	●	●	●	EP2
			With inlet filtration	U=12V DC		●	●	●	●	EP3
				U=24V DC		●	●	●	●	EP4
		With switching solenoid	Without inlet filtration	U=12V DC		●	●	●	●	EZ1
				U=24V DC		●	●	●	●	EZ2
			With inlet filtration	U=12V DC		○	○	○	○	EZ3
				U=24V DC		○	○	○	○	EZ4

Brake Valve

C	Without brake valve (without code)			71	80	90	100		
				●	●	●	●		
	Only for HW control valve on the HW valve body	NO	U=12V DC		○	○	○	○	O1
			U=24V DC		●	●	●	●	O2
		NC	U=12V DC		○	○	○	○	C1
			U=24V DC		●	●	●	●	C2
	All control valve on the back cover	NO	U=12V DC		—	—	—	—	O3
			U=24V DC		—	—	—	—	O4
		NC	U=12V DC		—	—	—	—	C3
			U=24V DC		—	—	—	—	C4



➤ Model Code

	c	A	B	C	D	E	F	G		I	K		M	N	P	R	S	T	U	X		Z	
HA4VT	G								/	39		-										-	

Neutral Position Switch(only for HW control)

D		71	80	90	100	
	Without neutral position switch (without code)	●	●	●	●	
	With neutral position switch (without code)	●	●	●	●	L

Pressure Cut-Off Valve

E		71	80	90	100	
	Without pressure cut-off valve (without code)	●	●	●	●	
	With pressure cut-off valve	●	●	●	●	D

Stroke Limiter

F		71	80	90	100	
	Without mechanical stroke limiter (without code)	—	—	●	●	
	With mechanical stroke limiter, externally adjustable	●	●	●	●	M

Stroking Chamber Pressure Port(X3/X4)

G		71	80	90	100	
	Without port X3/X4 (without code)	●	●	●	●	
	With port X3/X4	●	●	●	●	T

Series

I		71	80	90	100	
	Series 39	●	●	●	●	39

Direction of Rotation (viewed on drive shaft)

K		71	80	90	100	
	CW (right-hand)	●	●	●	●	R
	CCW (left-hand)	●	●	●	●	L

Sealing Material

M		71	80	90	100	
	NBR seal + FKM Shaft seal	●	●	●	●	N
	NBR seal + NBR Shaft seal	●	●	●	●	P
	FKM seal + FKM Shaft seal	●	●	●	●	V



> Model Code

	c	A	B	C	D	E	F	G		I	K		M	N	P	R	S	T	U	X	Z	
HA4VT	G							/	39			-									-	

Drive Shaft

N			71	80	90	100		
	SAE 1 1/4" 14T 12/24DP		●	●	●	●	U	
	SAE 1 3/8" 21T 16/32DP		●	●	●	●	R	
	SAE 1 1/2" 23T 16/32DP	Without connecting flange		●	●	●	●	S
		With connecting flange		●	●	●	●	L
SAE 1 3/4" 13T 8/16DP		●	●	●	●	T		

Mounting Flange

P		71	80	90	100	
	SAE J7444-4 hole(127-4)	●	●	●	●	D
	SAE J744-4 hole+2 hole(127-2/4)	●	●	●	●	F

Working Ports (viewed on drive shaft)

R	Opposite side	Suction port downwards	71	80	90	100	02
		Suction port upwards	●	●	●	●	03
	Same side	Suction port upwards, working port rightwards	●	●	●	●	10
		Suction port downwards, working port leftwards	●	●	●	●	13

Boost Pump and Through Drive¹⁾

S	Integrated boost pump	Without through drive		71	80	90	100	F00
		Flange SAE J 774-82-2(A)	Splined shaft 5/8" 9T 16/32DP	●	●	●	●	F01
			Splined shaft 3/4" 11T 16/32DP	●	●	●	●	F52
		Flange SAE J 774-101-2(B)	Splined shaft 7/8" 13T 16/32DP	●	●	●	●	F02 ²⁾
			Splined shaft 7/8" 13T 16/32DP	●	●	●	●	F68
			Splined shaft 1" 15T 16/32DP	●	●	●	●	F04
		Flange SAE J 774-127-2/4(C)	Splined shaft 1 1/4" 14T 12/24DP	●	●	●	●	F07
	Without integrated boost pump	Without through drive		●	●	●	●	N00
		Flange SAE J 774-82-2(A)	Splined shaft 5/8" 9T 16/32DP	●	●	●	●	K01
			Splined shaft 3/4" 11T 16/32DP	●	●	●	●	K52
		Flange SAE J 774-101-2(B)	Splined shaft 7/8" 13T 16/32DP	●	●	●	●	K02
			Splined shaft 7/8" 13T 16/32DP	●	●	●	●	K68
			Splined shaft 1" 15T 16/32DP	●	●	●	●	K04
		Flange SAE J 774-127-2/4(C)	Splined shaft 1 1/4" 14T 12/24DP	●	●	●	●	K07

1) Splined shaft standard ANSI B92.1-1970 Level 6.

F07 can be connected in series by adding a transition spigot“SAE J744 C 4 hole(4*Φ14,Φ127h8 12.7), Splined shaft 1 1/4" 14T 12/24DP”.

2) The sealing method of this transition plate is radial sealing, while all others employ axial sealing.Should you have specific sealing requirements, please contact our company.



➤ Model Code

	c	A	B	C	D	E	F	G		I	K		M	N	P	R	S	T	U	X		Z
HA4VT	G								/	39		-									-	

High-Pressure Relief Valve³⁾

		71	80	90	100	
T	Direct operated, Without bypass (Standard Pressure 40MPa)	●	●	●	●	5
	Direct operated, With bypass (Standard Pressure 40MPa)	●	●	●	●	6

Filtration⁴⁾

		71	80	90	100	
U	Integrated filter, without cold start valve, without contamination indicator	●	●	●	●	A
	Integrated filter, without cold start valve, with contamination indicator	●	●	●	●	G
	Integrated filter, with cold start valve, without contamination indicator	●	●	●	●	F
	Integrated filter, with cold start valve, with contamination indicator	●	●	●	●	P
	Integrated filter, with cold start valve, with electrical signals contamination indicator	○	○	○	○	B
	Integrated filter, With bypass function, with electrical signals contamination indicator	●	●	●	●	M
	External suction filter (not included in delivery, to be selected by customer)	●	●	●	●	S
	External pressure filter (not included in delivery, to be selected by customer)	●	●	●	●	D
	External fluid supply (only for N00, K**)	●	●	●	●	E

Solenoid Connector

		71	80	90	100	
X	Without solenoid (without code)	●	●	●	●	
	DEUTSCH molded connector, 2-pin, without suppressor diode ⁵⁾	●	●	●	●	P

Special Configuration⁶⁾

		71	80	90	100	
Z	Without special configuration (without code)	●	●	●	●	
	Special configuration	●	●	●	●	***

● Available ○ On request — Not available ■ Recommended model

3) The optional pressures for the direct-acting high-pressure relief valve are: 20/22/~40/42, in MPa; with a bypass function for vehicle towing.
 4) Filtration: F/P/B opposite side ports are available; E same side ports are not available.
 5) For HWO/HWC/EP/EZ control, model: DeutschDT04-2P.
 6) For specific special configurations, please contact our company.



➤ Structure

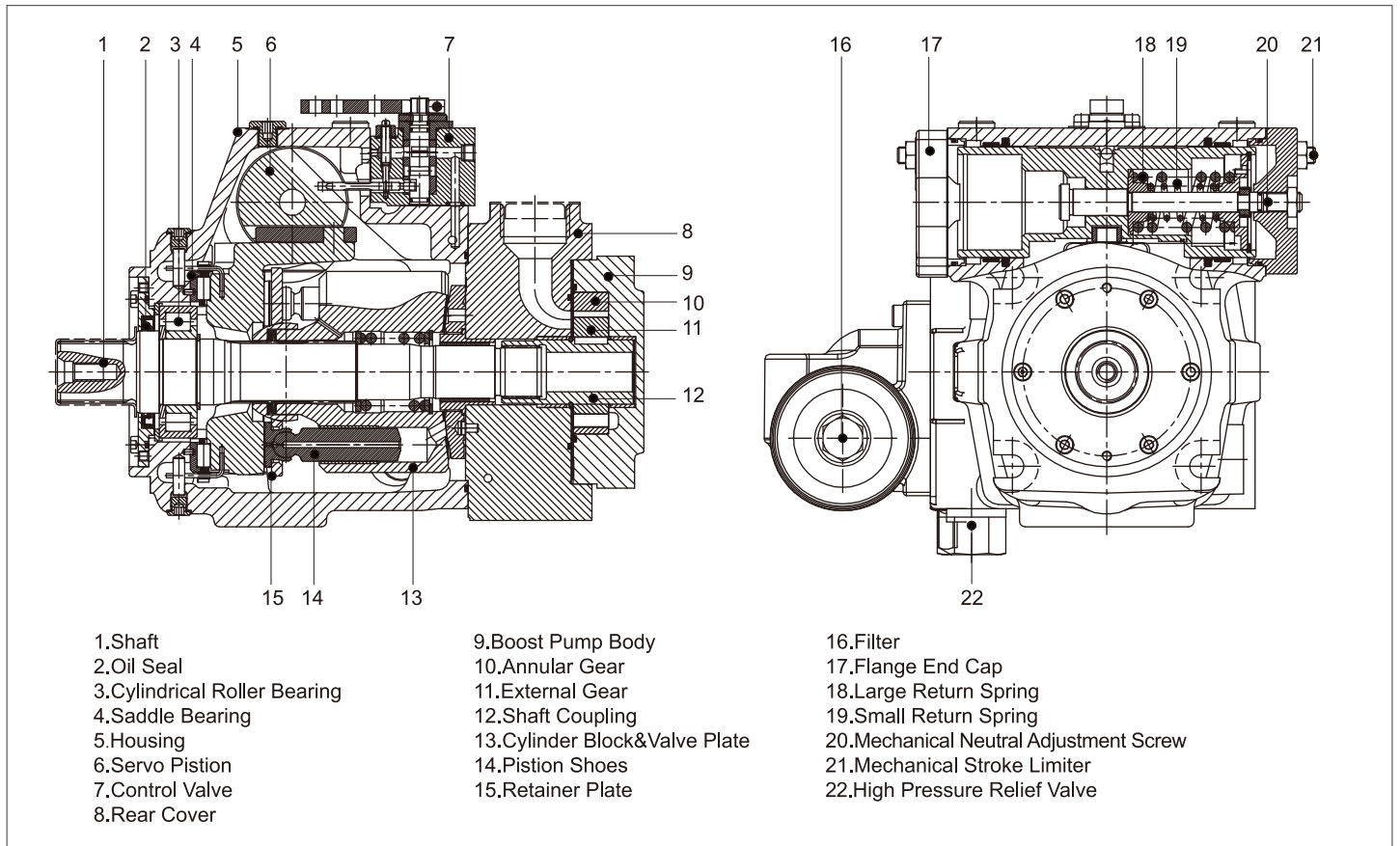

➤ Circuit Diagram

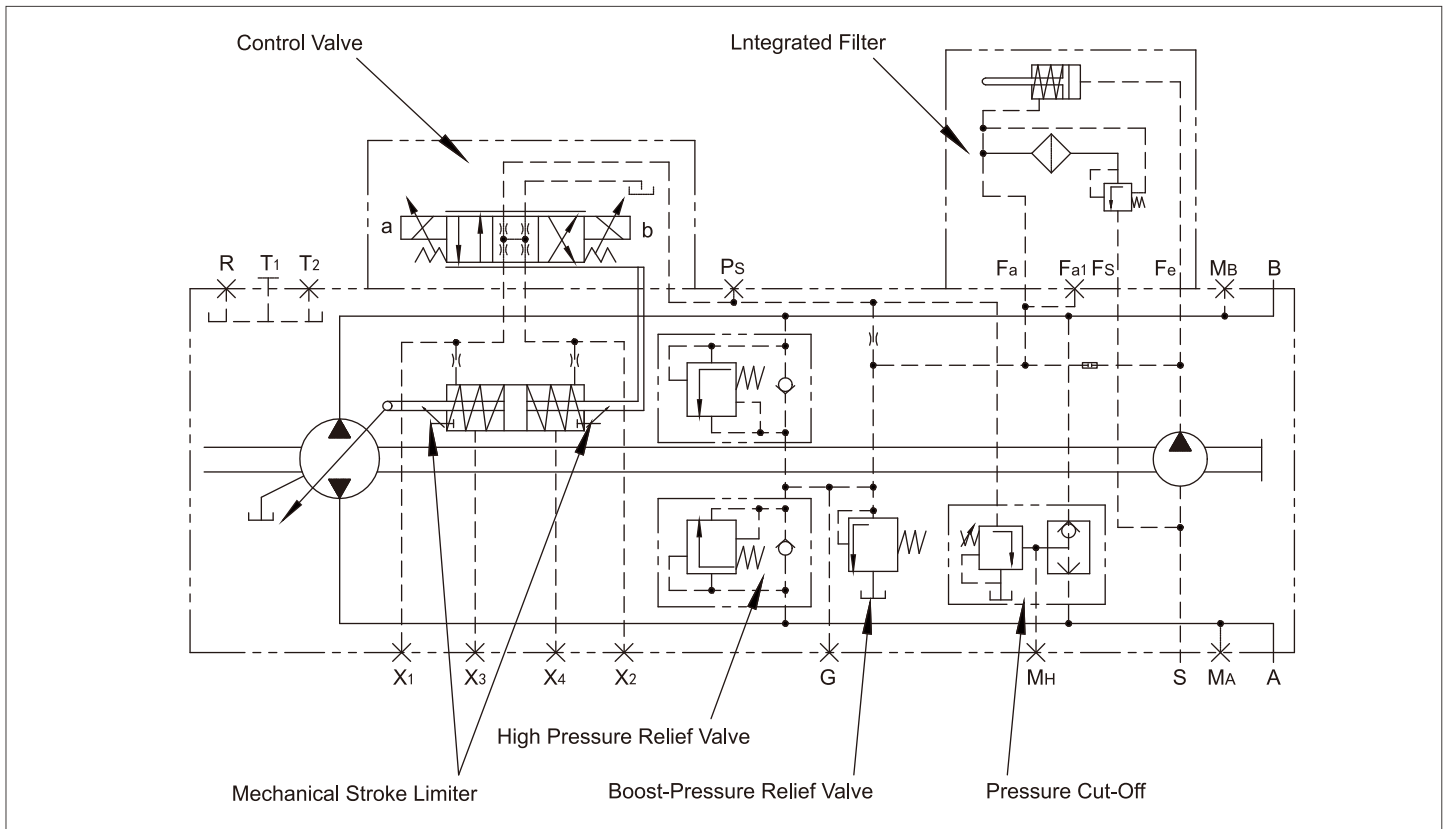



> Hydraulic Fluid

Mineral oil

> Working Viscosity

In order for the optimum efficiency and service life, select the working viscosity at recommended working temperature within the range of

$$V_{opt} = \text{optimum operating viscosity } 16 \cdots 36 \text{ mm}^2/\text{s}$$

depending on the closed circuit temperature.

> Limit Viscosity

Limit viscosity:

$$V_{min} = 5 \text{ mm}^2/\text{s}$$

Short-term ($t < 3 \text{ min}$)

Permissible max. temperature $t_{max} = +115^\circ\text{C}$

$$V_{max} = 1600 \text{ mm}^2/\text{s}$$

Short-term ($t < 3 \text{ min}$)

Cold start ($p \leq 3 \text{ Mpa}$, $n \leq 1000 \text{ rpm}$, $t_{min} = -40^\circ\text{C}$)

Only for start in unloaded condition; it must reach the optimal working temperature within 15 min.

> Selection Diagram

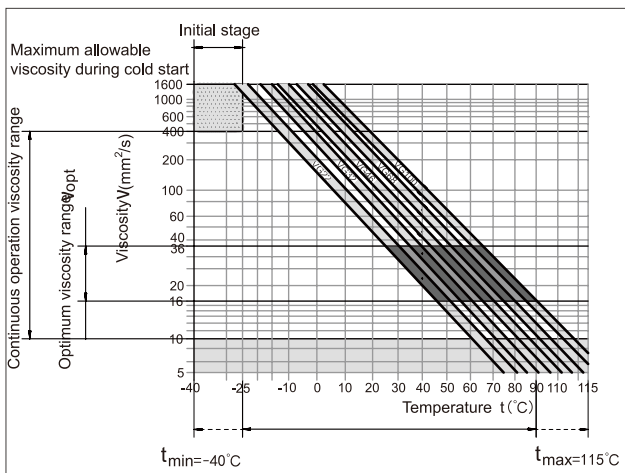

> Instructions on Selection of Hydraulic Fluid

The hydraulic fluid should be selected so that the operating viscosity in the operating temperature range is within the optimum range (V_{opt} ; see selection diagram).

Example: The working temperature of the circuit is 50°C at the ambient temperature of $X^\circ\text{C}$. The corresponding viscosity grade within the optimal working viscosity range (V_{opt} ; see selection diagram) is VG46 or VG68, and VG68 should be selected.

Note: The case drain temperature depends on the pressure and speed, and it is always higher than the circuit temperature. The temperature at any point within the system should not exceed $+115^\circ\text{C}$.

Please consult us if the above conditions cannot be maintained in extreme working parameters.

> Filtration

The finer the filtration is the cleaner the fluid and the longer the service life of axial piston unit. To ensure normal operation of the axial piston unit, the fluid cleanliness should at least reach

ISO4406 code 20/18/15

On the system and application:

Discharge filter $\beta_{15-20} \geq 75$

Suction and return filter $\beta_{35-45} \geq 75$

β should not fall when differential pressure of the filter element rises.

When the fluid temperature is high ($+90^\circ\text{C}$ to $+115^\circ\text{C}$), the cleanliness should at least reach

ISO 4406 code 19/17/14

Please consult us if the above grade cannot be maintained. See "Mounting Connection Dimensions - Filter" for the filter model.

> Working Pressure Range

Input

Variable pump (with external boost pump):

HD, HW, EZ&EP

Boost pressure ($n=1500 \text{ rpm}$) P_{sp} _____ 20bar

Boost pump:

Suction port $P_{s \text{ min}}$ ($v \leq 30 \text{ mm}^2/\text{s}$) _____ $\geq 0.8 \text{ bar absolute}$

Short-term, at cold start ($t < 3 \text{ min}$) _____ $\geq 0.5 \text{ bar absolute}$

Output

Variable pump:

Pressure at port A or B

Nominal pressure P_{nom} _____ 400bar

Max. pressure P_{max} _____ 420bar

Total pressure (pressure A + pressure B) P_{max} _____ 700bar

Boost pump:

Max. pressure $P_{sp \text{ max}}$ _____ 40bar

> Oil Seal

Allowable pressure load

The life of the shaft seal depends on pump speed and case drain pressure. The average persistent case drain pressure at the recommended working temperature should not exceed 3 bar absolute (the max. allowable case drain pressure is 6 bar when the speed falls), and the short-term ($t < 0.1 \text{ s}$) allowable peak absolute is max. 10 bar. The more frequent the occurrences of peak pressure, the shorter the life of the shaft seal.

Temperature range

FKM shaft seal is used within the case temperature range of -25°C to $+115^\circ\text{C}$.

NBR shaft seal is intended for the case temperature range of -40°C to $+90^\circ\text{C}$.



Technical Data

Size				71	80	90	100
Displacement	Variable pump	$V_{g \max}$	mL/r	71	80	90	100
	Boost pump ($\Delta p=20\text{bar}$)	$V_{g \text{SP}}$	mL/r	19.6/28.3			
Rated pressure			MPa	40			
Max. pressure			MPa	45			
Speed	Max. speed at $V_{g \max}$	$n_{o \max \text{ sustain}}$	rpm	3050			
	Min. speed	n_{\min}	rpm	500			
Flow	At $n_{o \max \text{ sustain}}$ & $V_{g \max}$	$q_{v \max}$	L/min	217	244	275	305
Power	At $n_{o \max \text{ sustain}}$, $\Delta p=40\text{MPa}$	n_{\min}	KW	145	163	183	203
Torque	At $V_{g \max}$, $\Delta p=40\text{MPa}$	T_{\max}	Nm	452	510	573	637
Moment of inertia around drive shaft		J	Kgm ²	0.0106			
Weight (standard)		m	KG	48			

The permissible radial and axial forces on the drive shaft comply with the ANSI B92.1a splined shaft standard

Size		NG		71	80	90	100
Drive Shaft				1 1/4"	1 3/8"	1 1/2"	1 3/4"
Maximum radial force at distance a (shaft spacing) ¹⁾		$F_{q \max}$	N	7100	7100	7100	6600
		a	mm	24	24	24	33.5
Maximum axial force		$+F_{ax \max}$	N	4330	4330	4330	4330
		$-F_{ax \max}$	N	2670	2670	2670	2670

Permissible input torque and through-shaft drive torque

Size		NG		71	80	90	100
Torque ($V_{g \max}$, $\Delta p=400\text{bar}$) ²⁾		T	Nm	452	510	573	637
Maximum input torque of the drive shaft ³⁾							
ANSI B92.1a(SAE J744)	U	$T_{E \max}$	Nm	1 1/4"	1 1/4"	1 1/4"	-
				602	602	602	-
	R	$T_{E \max}$	Nm	1 3/8"	1 3/8"	1 3/8"	1 3/8"
				970	970	970	970
	S/L	$T_{E \max}$	Nm	1 1/2"	1 1/2"	1 1/2"	1 1/2"
				1350	1350	1350	1350
	T	$T_{E \max}$	Nm	1 3/4"	1 3/4"	1 3/4"	1 3/4"
				1640	1640	1640	1640
Maximum through-shaft drive torque ⁴⁾		$T_{D \max}$	Nm	660	660	660	660

1) No-load condition Note: Please contact us when using belt drives and universal joint shafts.

2) Efficiency not considered.

3) Applies to drive shafts without radial force.

4) Note the maximum input torque of the drive shaft.



➤ Torque Distribution

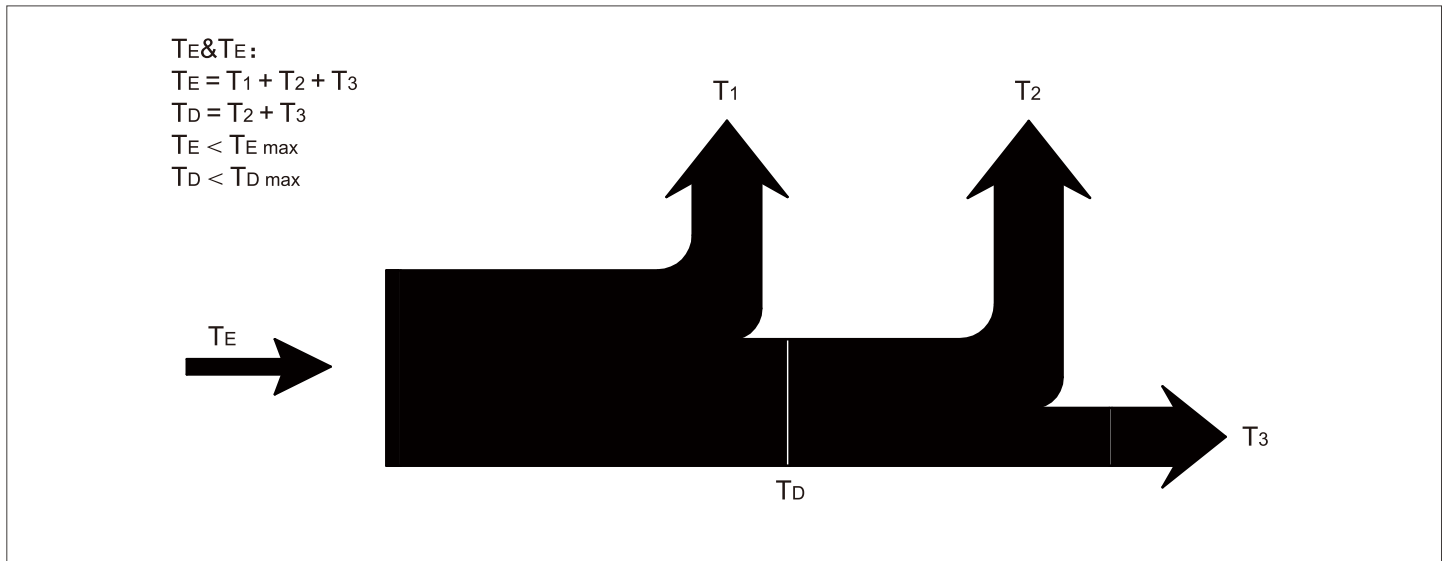

➤ Specification Calculation

Flow	$q_v = \frac{V_g \cdot n \cdot \eta_v}{1000}$	[L/min]	V_g = Displacement, mL/r
			Δp = Differential pressure, MPa
Torque	$T = \frac{V_g \cdot \Delta p}{2 \cdot \pi \cdot \eta_{mh}}$	[Nm]	n = Rotational speed, rpm
			η_v = Volumetric efficiency
Power	$P = \frac{2\pi \cdot T \cdot n}{60000} = \frac{q_v \cdot \Delta p}{60 \cdot \eta_t}$	[KW]	η_{mh} = Hydraulic-mechanical efficiency
			η_t = Total efficiency



> HW-Mechanical Servo Control

Depending on the moving direction (a or b) of the control lever, the variable cylinder of the pump obtains control pressure through the HW control so that the swashplate moves and realizes stepless displacement regulation. Each direction of the control lever corresponds to one flow direction.

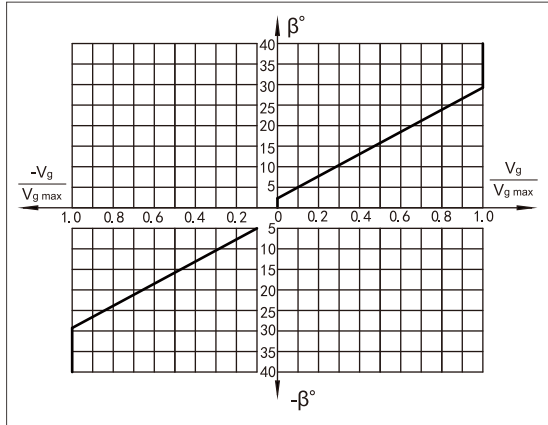

β , swivel angle at the control lever:
 $\beta=3^\circ$ at start point of control
 $\beta=29^\circ$ at end point of control (max. displacement V_{gmax})
 mechanical limit of lever: $\pm 40^\circ$

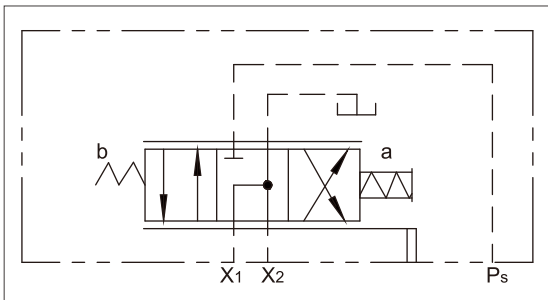

Variant I: with neutral position switch,HWL

With the control lever of the HW control valve in its neutral position, the neutral position switch is off; when the lever of the control valve turns to any side away from the neutral position, the switch is on.

The neutral position switch is intended to protect the system that needs to keep zero flow in certain conditions, such as start of engine.

Neutral Position Switch Specification	
Switching capacity	5A/12V&3A/24V
Connector version	DJ7021-1.8-20

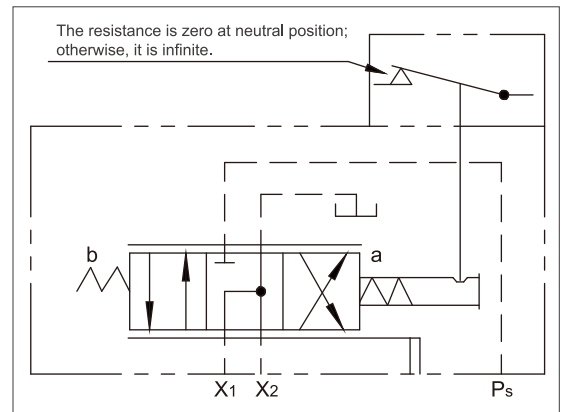



Variant II: with brake valve,HWO/HWC

Solenoid Specification	HWO(C)1	HWO(C)2
Voltage	12V DC(±1.8V)	24V DC(±3.6V)
Nominal resistance(20°C)	9Ω	36Ω
Rated power	18W	18W
Required min. current	1.5A	0.75A
Working time	100%	
Protection rating	IP67	

With NO brake valve,HWO,power loss braking

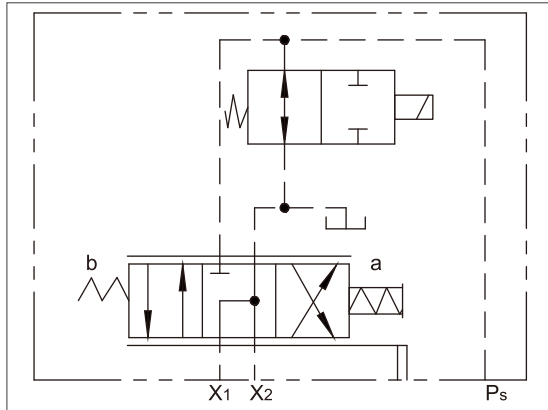

With NC brake valve,HWC,electric braking

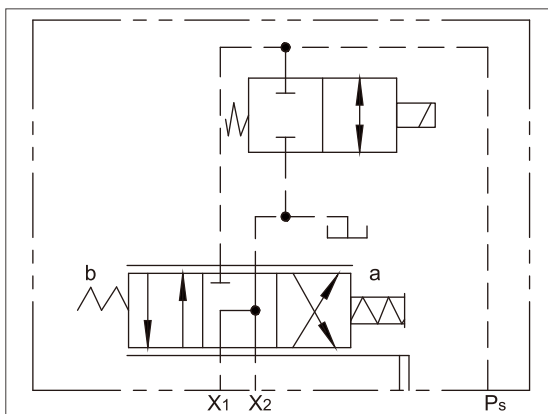

Variant III: with brake valve and neutral position switch, HWOL/HWCL

With NO brake valve and neutral position switch, HWOL

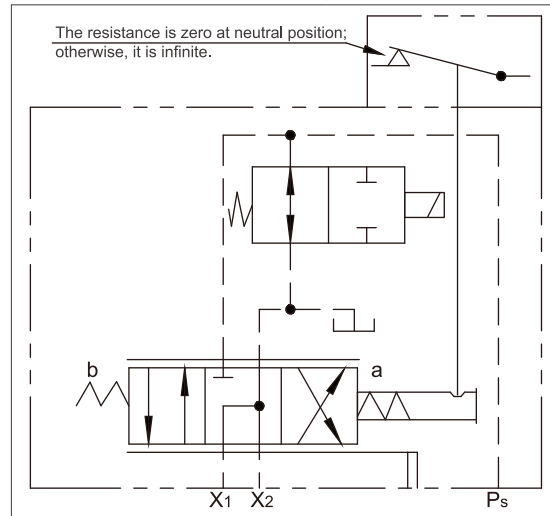

With NO brake valve and neutral position switch, HWCL

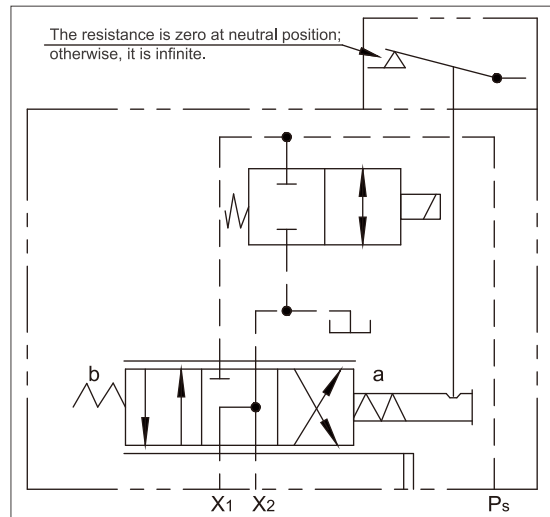

Rotation of Direction of Rotation,Control and Flow Direction

Direction of Rotation (viewed on shaft end)	CW		CCW	
	a	b	a	b
Direction of control lever	a	b	a	b
Variable pressure	X2	X1	X2	X1
Flow direction	B→A	A→B	A→B	B→A
Working pressure	MA	MB	MB	MA

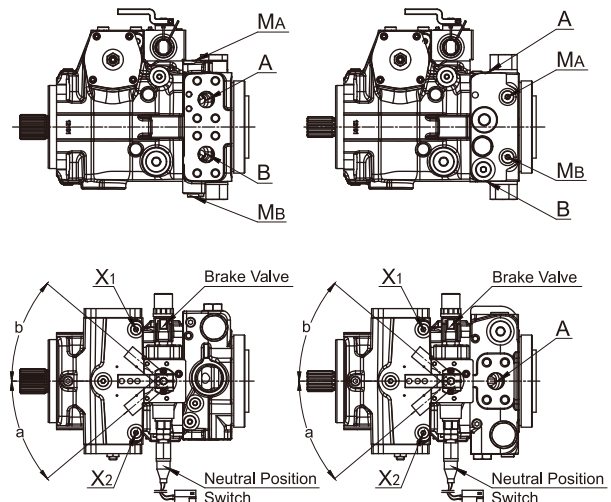



HD-Pilot Pressure Control

Depending on the difference between pilot pressures P_{st} (port Y_1 and Y_2) of two control lines, the variable cylinder of the pump obtains control pressure through the HD control so that the swashplate moves and realizes stepless displacement regulation. Each control line corresponds to one flow direction.

HD1: without supply filter (N/A to new project!)

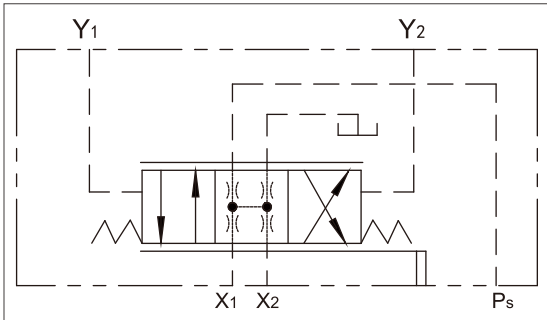

HD3: with supply filter (standard)

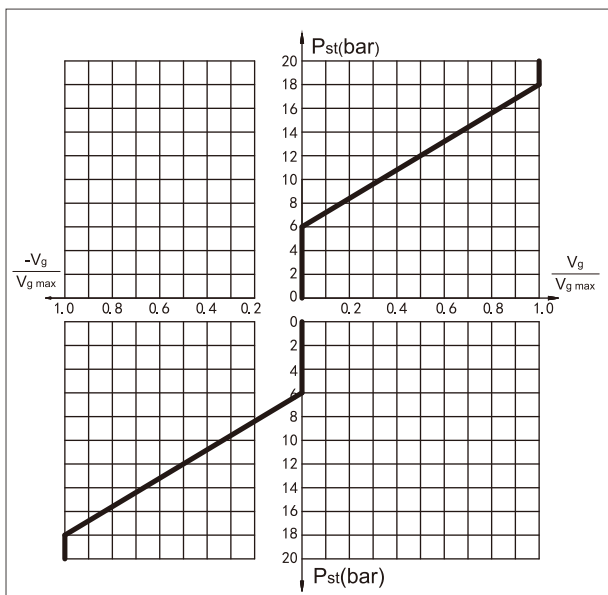
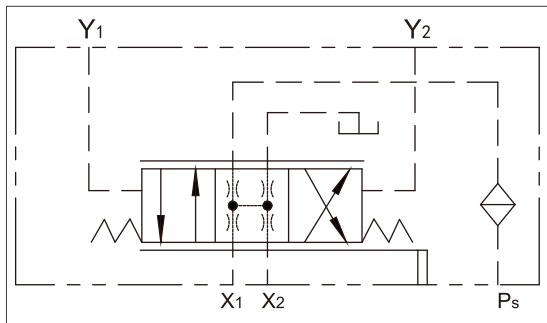

- V_g Displacement at P_{St}
- $V_{g\ max}$ Displacement at $P_{St}=18\text{bar}$
- Pilot pressure at port $Y_1/Y_2:P_{St}=6-18\text{bar}$
- Control start point: 6bar
- Control end point: 18 bar (max. displacement $V_{g\ max}$)

Precautions

HD control must be released to zero with the external pilot control device on the reservoir.

The spring at the center of the pilot control device is not a safety device.

The valve spool may get stuck in any position due to contamination of the control device by pollutants in the hydraulic fluid, wear debris, particulate matters from outside the system, etc. In this case, the pump flow can no longer be controlled with the operator's command.

- Make sure the driven machine can be moved to a safe state (e.g. stop) promptly with the emergency stop.
- Always observe the cleanliness code 20/18/15 ($< 90\text{ }^\circ\text{C}$) or 19/17/14 ($\geq 90\text{ }^\circ\text{C}$ or $< 115\text{ }^\circ\text{C}$) specified in ISO 4406.

Correlation of Direction of Rotation, Control and Flow Direction

Direction of Rotation (viewed on shaft end)	CW		CCW	
	Y_1	Y_2	Y_1	Y_2
Pilot pressure	Y_1	Y_2	Y_1	Y_2
Variable pressure	X_1	X_2	X_1	X_2
Flow direction	$A \rightarrow B$	$B \rightarrow A$	$B \rightarrow A$	$A \rightarrow B$
Working pressure	M_B	M_A	M_A	M_B

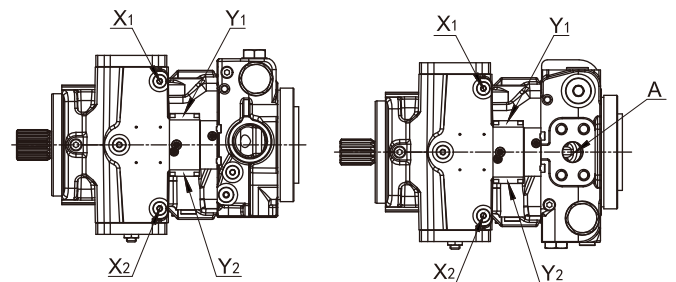
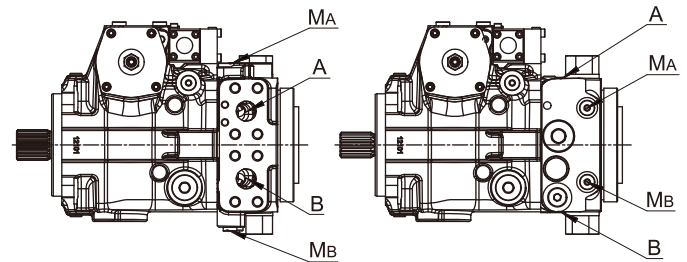



➤ EP-Electrical Control with Proportional Solenoids

Depending on the preset current I of proportional solenoids (a and b) on both ends of the valve, the variable cylinder of the pump obtains control pressure through the EP control so that the swashplate moves and realizes stepless displacement control. Each proportional solenoid corresponds to one flow direction.

Solenoid specification	EP1/3	EP2/4
Voltage	12V DC(±20%)	24V DC(±20%)
Control current		
Control start point $V_g=0$	400mA	200mA
Control end point $V_g \text{ max}$	1200mA	600mA
Limit current	1.54A	0.77A
Nominal resistance(20°C)	5.5Ω	22.7Ω
Vibration frequency	100Hz	
Working time	100%	
Protection rating	IP67	

EP1/2: without supply filter (N/A to new project!)

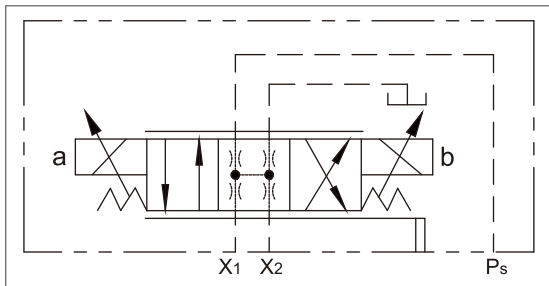

EP3/4: with supply filter (standard)

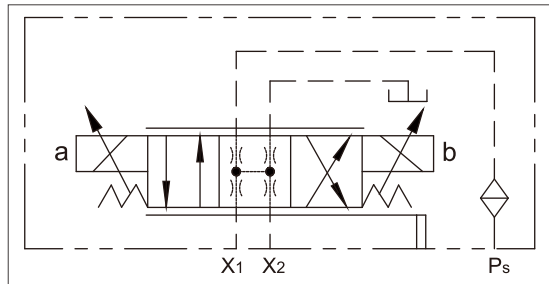

Precautions

The spring at the center of the pilot control device is not a safety device.

The valve spool may get stuck in any position due to contamination of the control device by pollutants in the hydraulic fluid, wear debris, particulate matters from outside the system, etc. In this case, the pump flow can no longer be controlled with the operator's command.

- Make sure the driven machine can be moved to a safe state (e.g. stop) promptly with the emergency stop.
- Always observe the cleanliness code 20/18/15 (< 90 °C) or 19/17/14 (≥ 90 °C or < 115 °C) specified in ISO 4406.

Correlation of Direction of Rotation, Control and Flow Direction

Direction of Rotation (viewed on shaft end)	CW		CCW	
	a	b	a	b
Solenoid actuation	a	b	a	b
Variable pressure	X1	X2	X1	X2
Flow direction	A→B	B→A	B→A	A→B
Working pressure	MB	MA	MA	MB

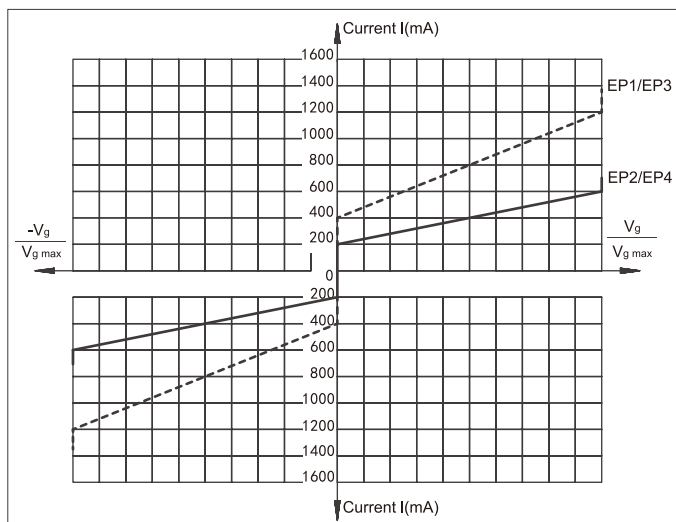
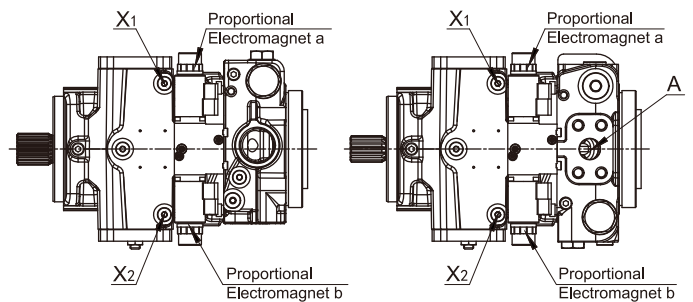
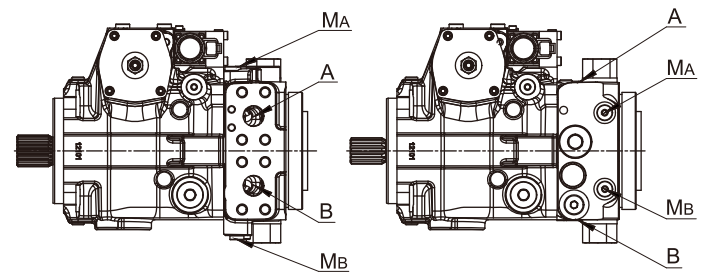



➤ EZ-Electrical Control with Switching Solenoids

Depending on on-off conditions of the switching solenoid (a or b) at both ends of the valve, the variable cylinder of the pump obtains control pressure through the EZ control so that the swashplate moves and regulates the displacement within the range of $V_g=0$ to V_{gmax} . Each solenoid corresponds to one flow direction.

Solenoid specification	EZ1/3	EZ2/4
Voltage	12V DC(±1.8V)	24V DC(±3.6V)
Neutral position $V_g=0$	OFF	OFF
Position V_g max	ON	20% ON
Nominal resistance(20°C)	5.5Ω	
Rated power	26.2W	26.5W
Required min. current	1.32A	0.67A
Working time		100%
Protection rating		IP65

Correlation of Direction of Rotation, Control and Flow Direction

Direction of Rotation (viewed on shaft end)	CW		CCW	
	a	b	a	b
Solenoid actuation	a	b	a	b
Variable pressure	X ₂	X ₁	X ₂	X ₁
Flow direction	B→A	A→B	A→B	B→A
Working pressure	MA	MB	MB	MA

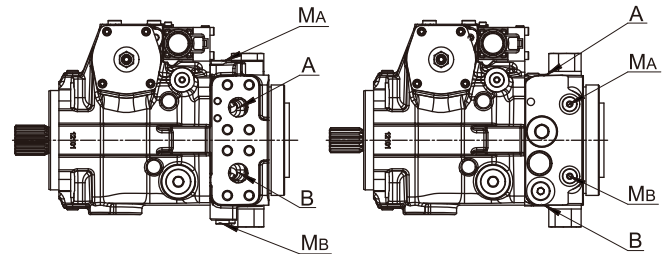

EZ1/2: without supply filter (N/A to new project!)

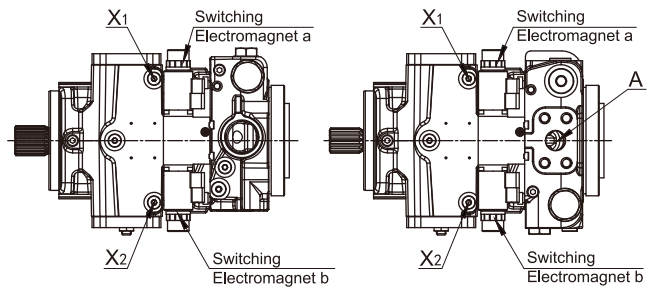
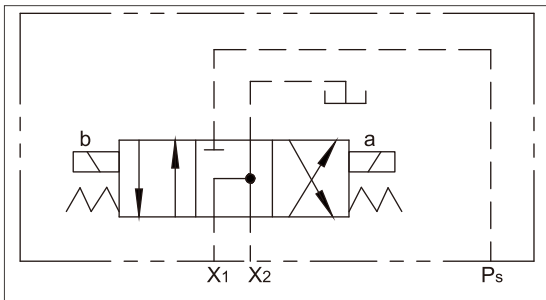

EZ3/4: with supply filter (standard)

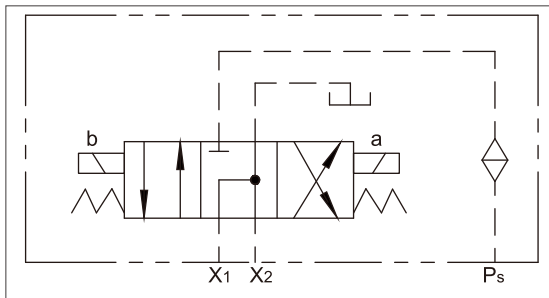



Connector for Solenoids

DEUTSCH DT04-2P-EP04, 2-pin
Molded, without bidirectional suppressor diode _____ P

The following type of protection ensues with the installed mating connector:
IP67(DIN EN 60520)
IP69K(DIN 60050-9)

Switching Symbol

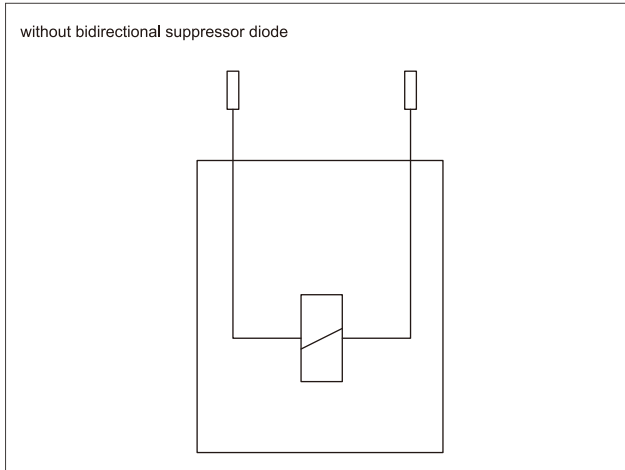

Mating Connector

DEUTSCH DT06-2S-EP04

Consisting of	DT
1 housing	DT06-2S-EP04
1 wedge	W2S
2 sockets	0462-201-16141

The mating connector is not included in the scope of delivery.

With emergency start and spring reset for Solenoid(EP/EZ)

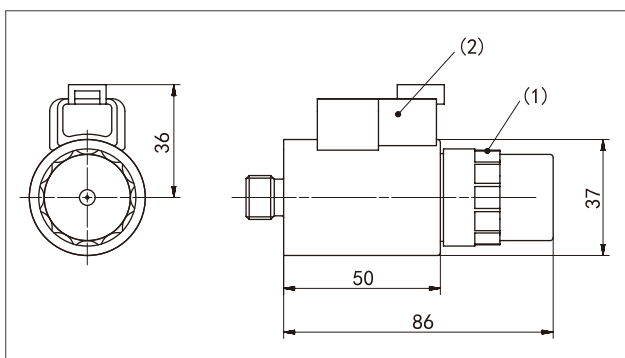

Brake Valve Solenoid (HWC/O)

Application of Construction Machinery

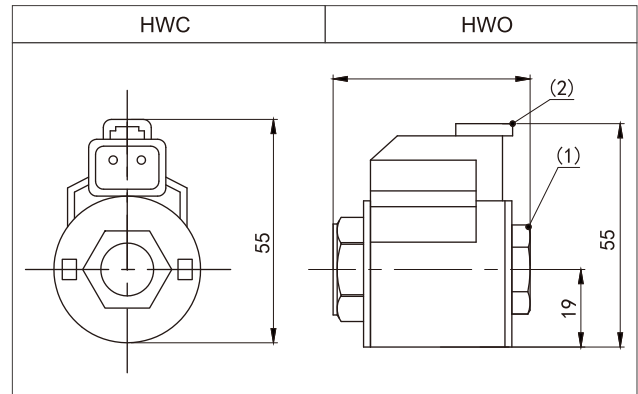

Application of Agricultural Machinery

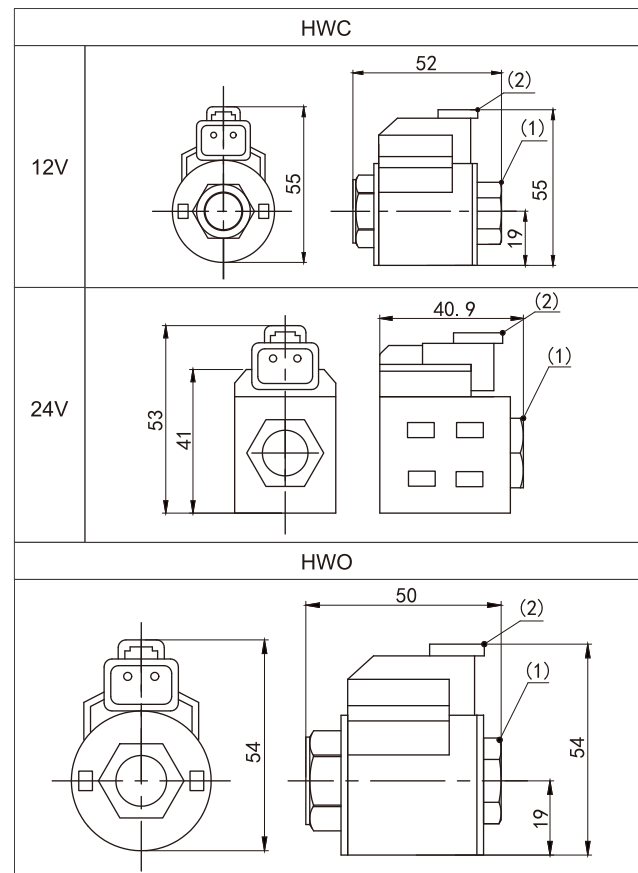

Notice

Manual emergency operation (emergency start) can be used in case of electrical system failure.

If necessary, you can change the position of the connector by turning the solenoid.

The position of the connectors varies of delivery.



➤ High Pressure Relief Valve

Two high-pressure relief valves are used to prevent overload of the hydrostatic drive (pump and motor). They limit the maximum pressure in each high-pressure line and simultaneously function as anti-cavitation valves. The high-pressure relief valves are not operational valves, they are solely suitable for handling pressure peaks or high rates of pressure change.

Setting Range

Direct Operated	MPa
	20
	22
	24
	28
	30
	32
	34
	36
	38
	40
	42

The factory setting of high pressure relief valve is 40 MPa and the boost-pressure relief valve is set to 2.0 MPa. Please specify other requirements, if any. Direct-acting valves without bypass (5) and with bypass (6) are available.

Bypass function

The bypass function allows the two high-pressure channels A and B to be connected (e.g., for towing the machine).

➤ Setting Diagram

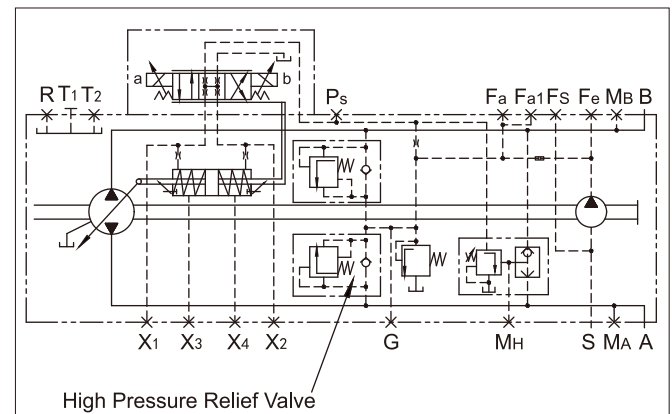



➤ Pressure Cut-off,D

Pressure cut-off is a pressure regulation function. The pump displacement is adjusted to $V_{g\ min}$ when the set pressure is reached, thus preventing action of the high pressure relief valve at acceleration or deceleration.

The high pressure relief valve offers protection at peak pressure and the maximum system pressure during rapid oscillation of the swashplate. The setting range of pressure cutoff may be any range within the overall working pressure range, but it must be lower than the high pressure relief valve setting of 20-30 bar.

➤ Stroking Chamber Pressure Port((X3/X4)

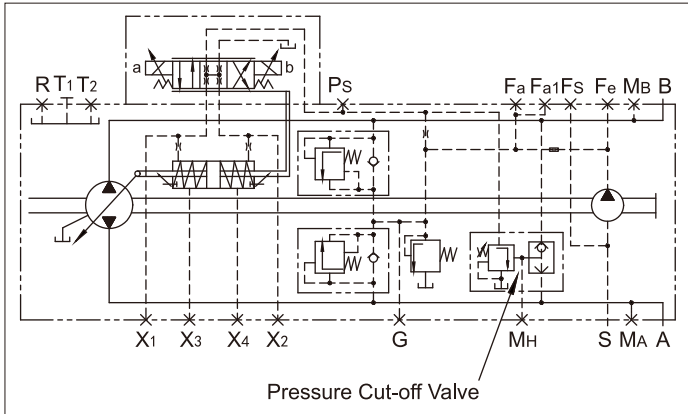
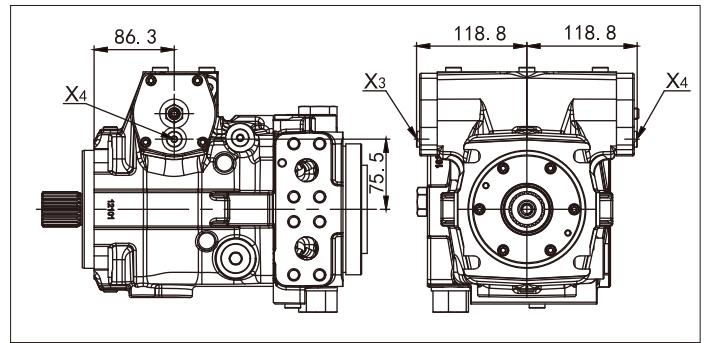
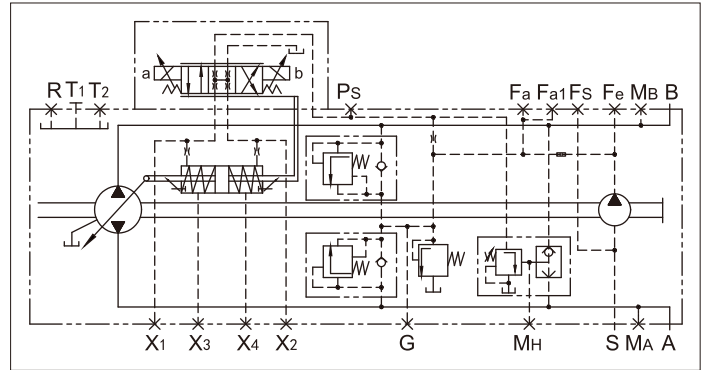

➤ Mechanical Stroke Limiter

The mechanical stroke limiter is one of the auxiliary functions, used to limit the maximum displacement of the pump to meet the needs of different displacements.it is independent of the flow control valve and flow control method used.

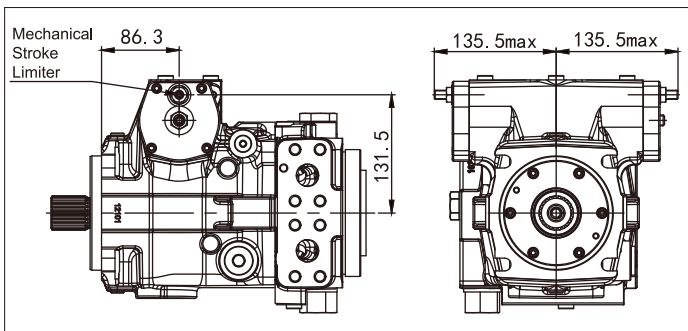
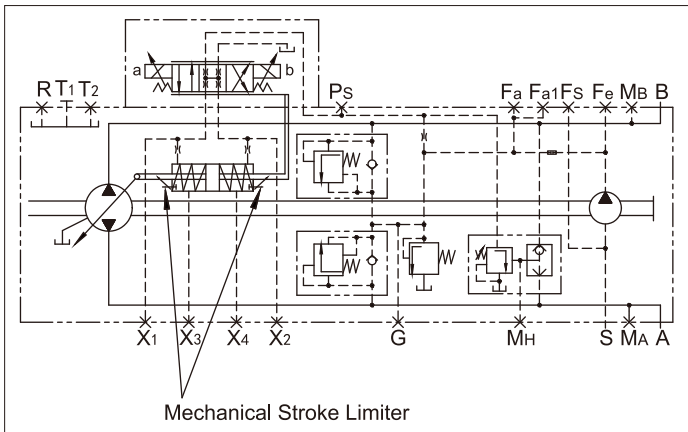



Filter

Model A: Filtration in the charge pump pressure line with a filter installed

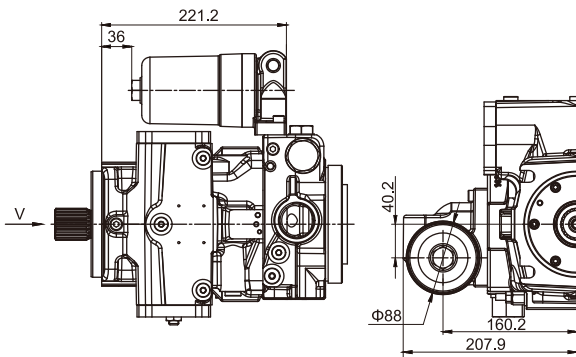
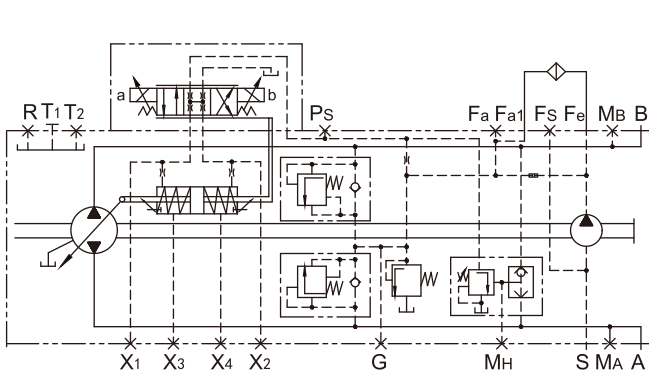

Model B: Filtration in the charge pump pressure line with a filter installed, equipped with a cold start valve and an electrical signal contamination indicator

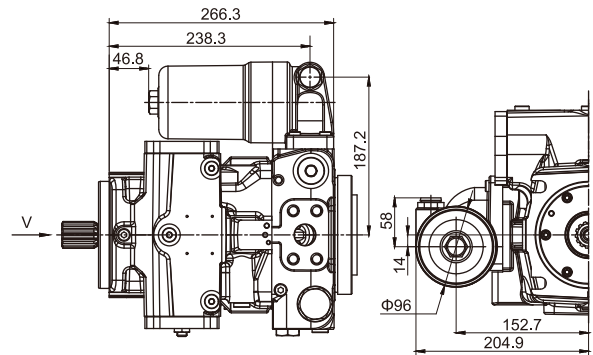
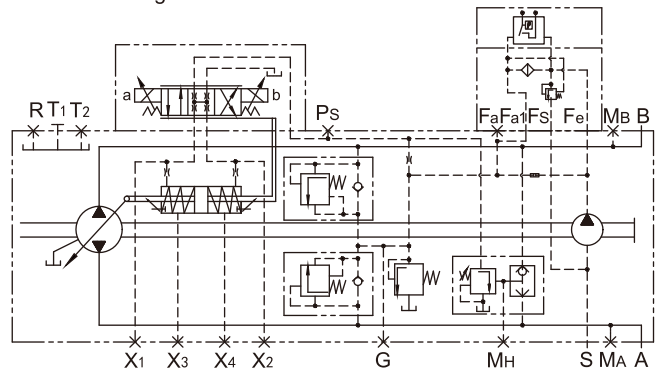

Model P: Filtration is provided in the charge pump pressure line with an installed filter, equipped with a cold start valve and a visual contamination indicator
Indicator: Green/Red viewing window
Differential pressure (cracking pressure) $\Delta p = 5\text{bar}$

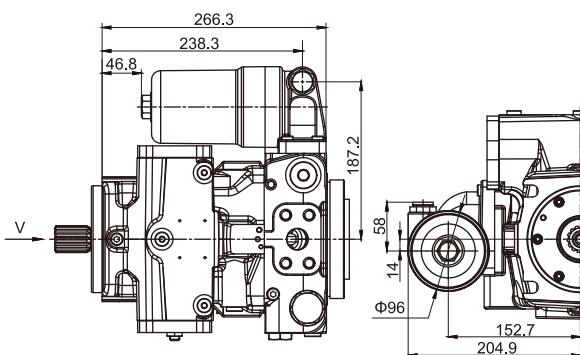
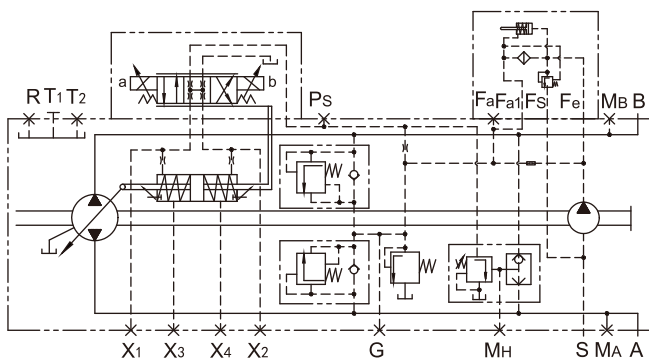

Model M: Filtration in the charge pump pressure line with an installed filter, equipped with a bypass valve and an electronic contamination transmitter (Deutsch connector)
Differential pressure (cracking pressure) $\Delta p = 5\text{bar}$

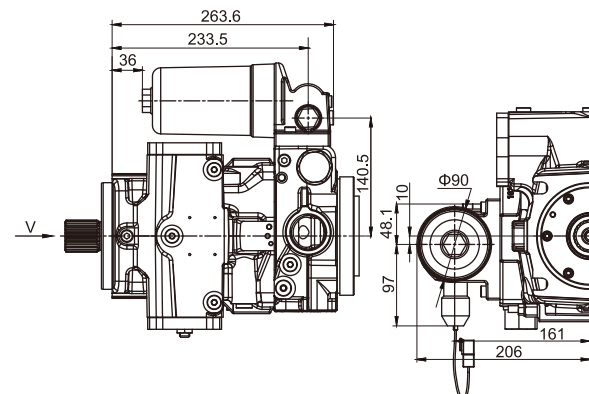
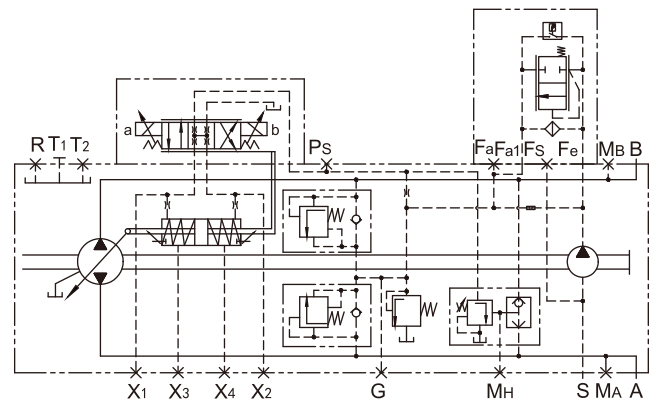



Filter

Model S: Filtration in the suction line of the charge pump
 Standard configuration (preferred option)
 Filter type: without bypass valve
 Recommended: with contamination indicator
 Filter element pressure drop:
 $v=30\text{mm}^2/\text{s}$, $n=n_{\text{max}}$ $\Delta p \leq 0.1\text{bar}$
 $v=1000\text{mm}^2/\text{s}$, $n=n_{\text{max}}$ $\Delta p \leq 0.3\text{bar}$
 Pressure at charge pump port S:
 $v=30\text{mm}^2/\text{s}$, $n=n_{\text{max}}$ $\Delta p \geq 0.8\text{bar}$
 Cold start
 $v=1600\text{mm}^2/\text{s}$, $n \leq 1000\text{rpm}$ $\Delta p \geq 0.5\text{bar}$

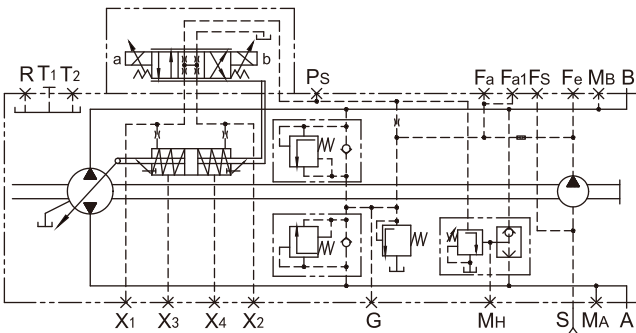

Not included in scope of supply

Note: Filters for this configuration are not included in our company's supply scope

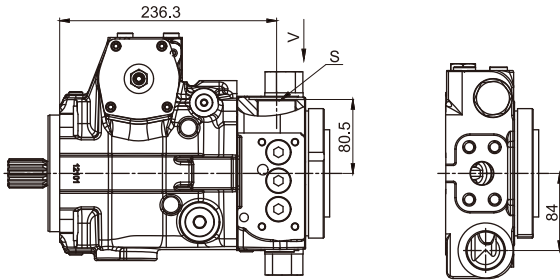

Model D: Filtration in the pressure line of the charge pump with ports for external charge circuit filter
 Filter inlet: Port Fe
 Filter outlet: Port Fa, Fa1
 Filter type:
 1. Filter with bypass valve is not recommended
 2. Contamination indicator is recommended

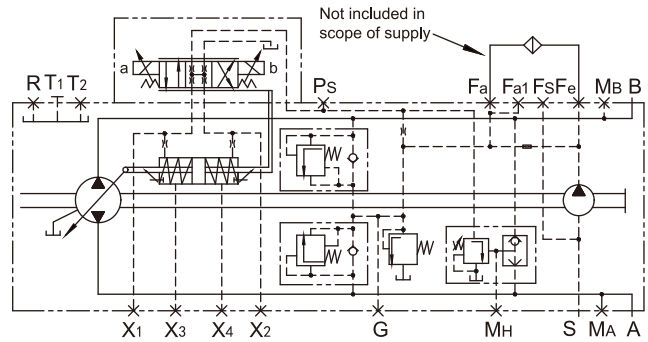

Not included in scope of supply

Note: Filters for this configuration are not included in our company's supply scope

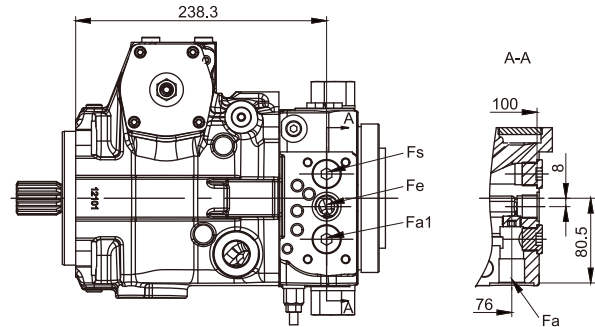

Model E: External oil supply filtration
 This variant is used for configurations without an integrated charge pump, such as types N00 or K...
 Port S is blocked, and the oil supply comes from port Fa or Fa1.
 Filter arrangement:
 For functional reliability, the filter should be installed separately.
 The cleanliness level of the charge oil at port Fa or Fa1 must be ensured (refer to "Technical Parameters - Filtration").

For filter models S/D/E, port dimensions refer to "Installation Connection Dimensions - Port Sizes"

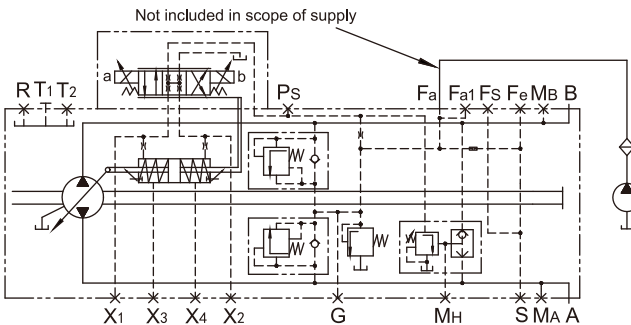

Not included in scope of supply

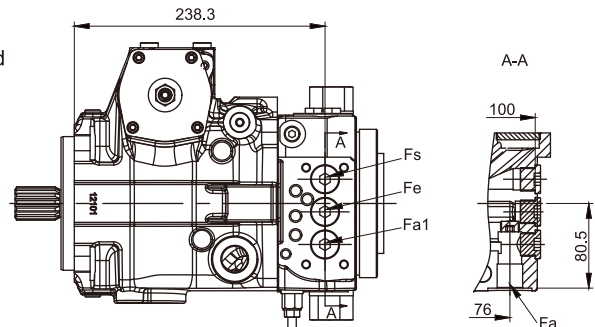



Installation Dimensions-Opposite side oil port 02

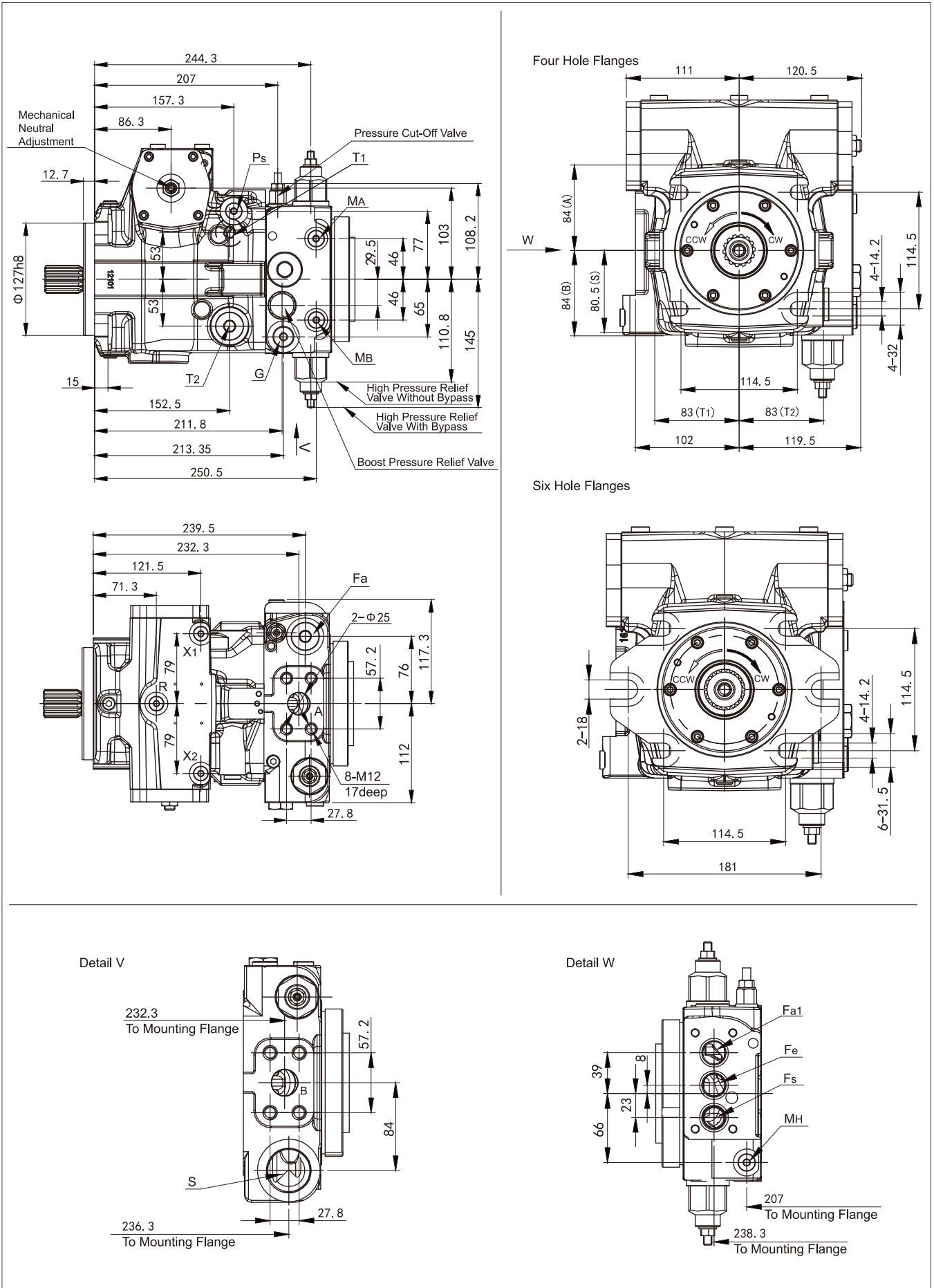



► Installation Dimensions-Opposite side oil port 03

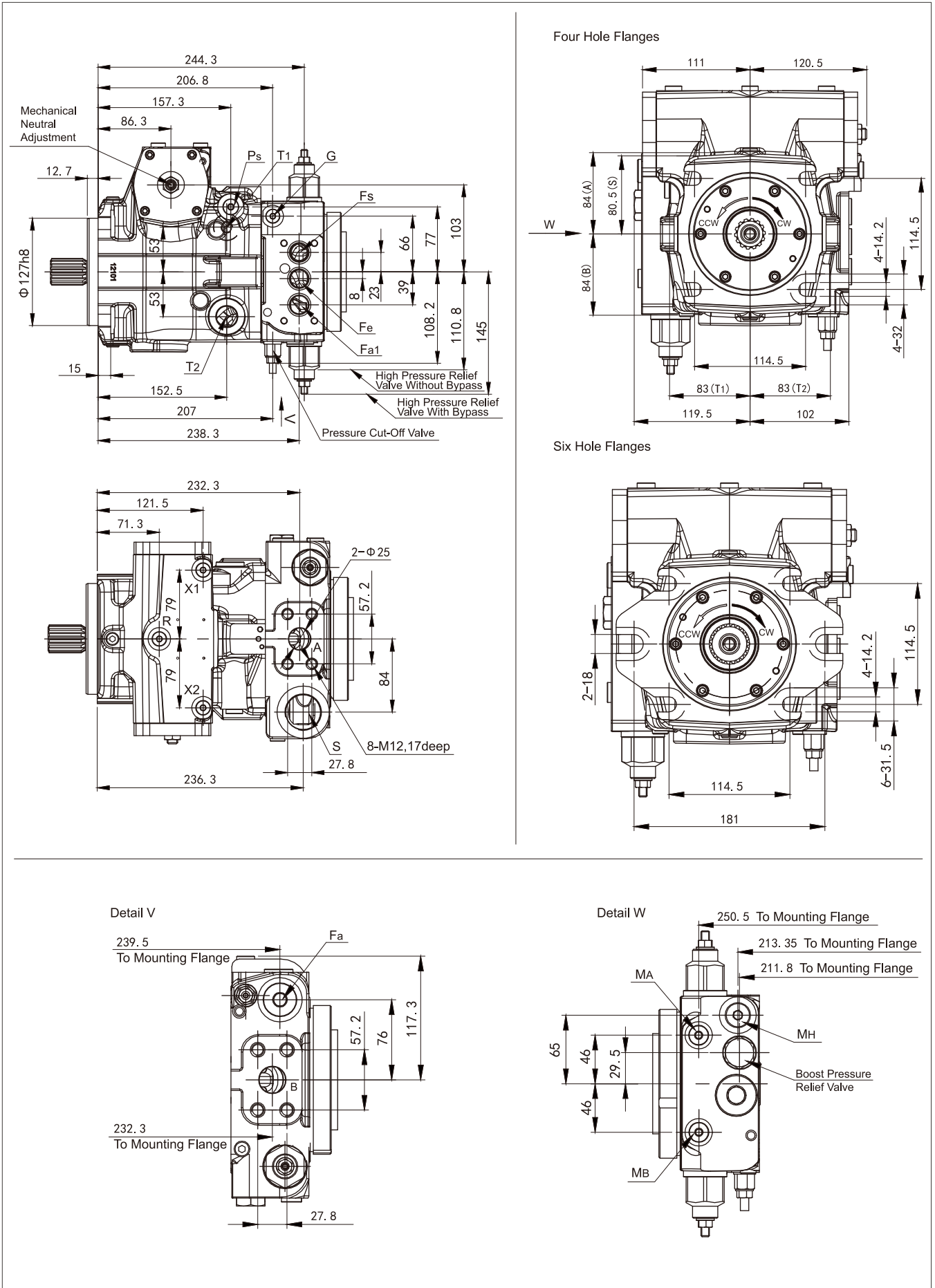



➤ Installation Dimensions-Same side oil port 10

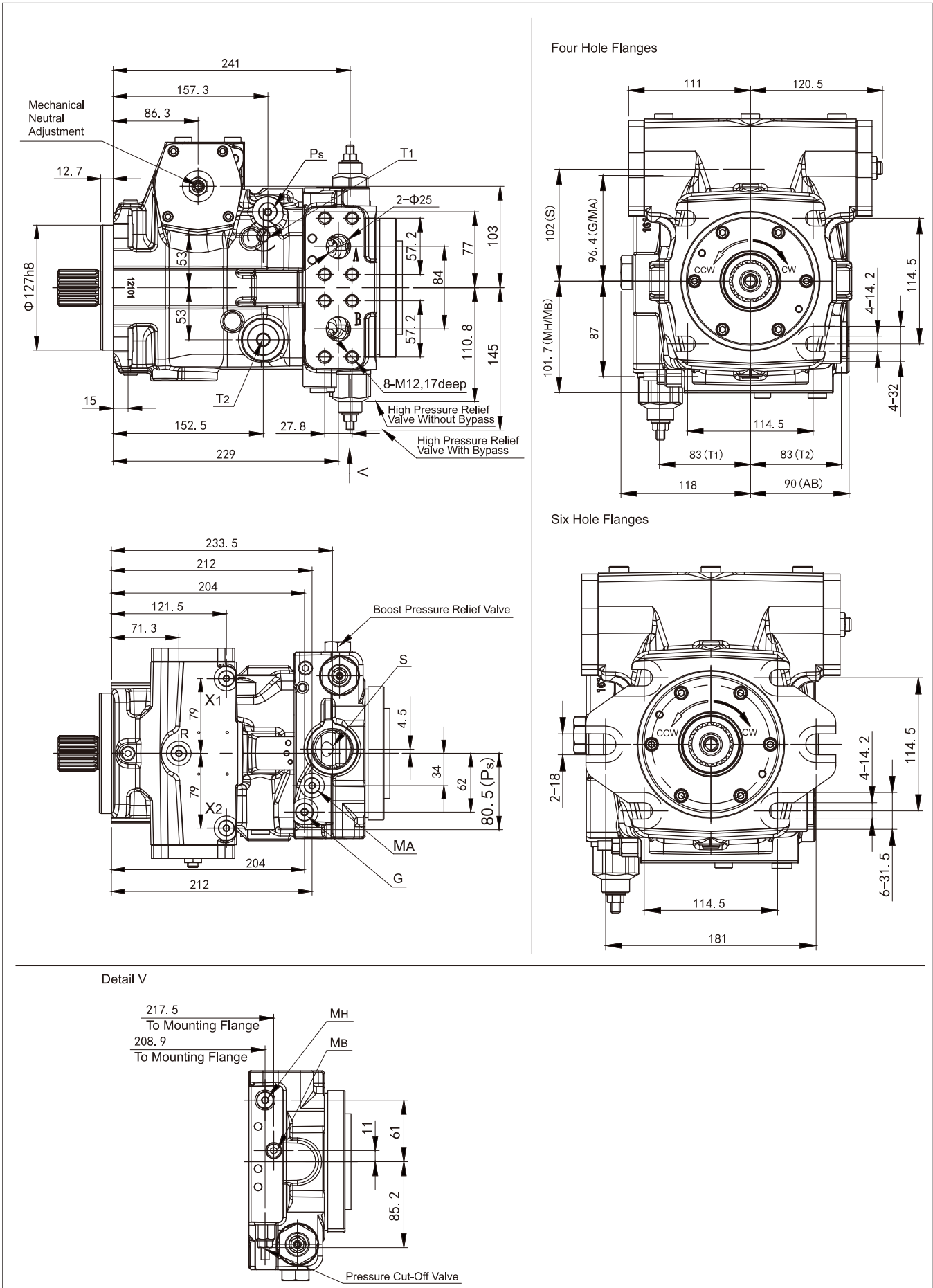



► Installation Dimensions-Same side oil port 13

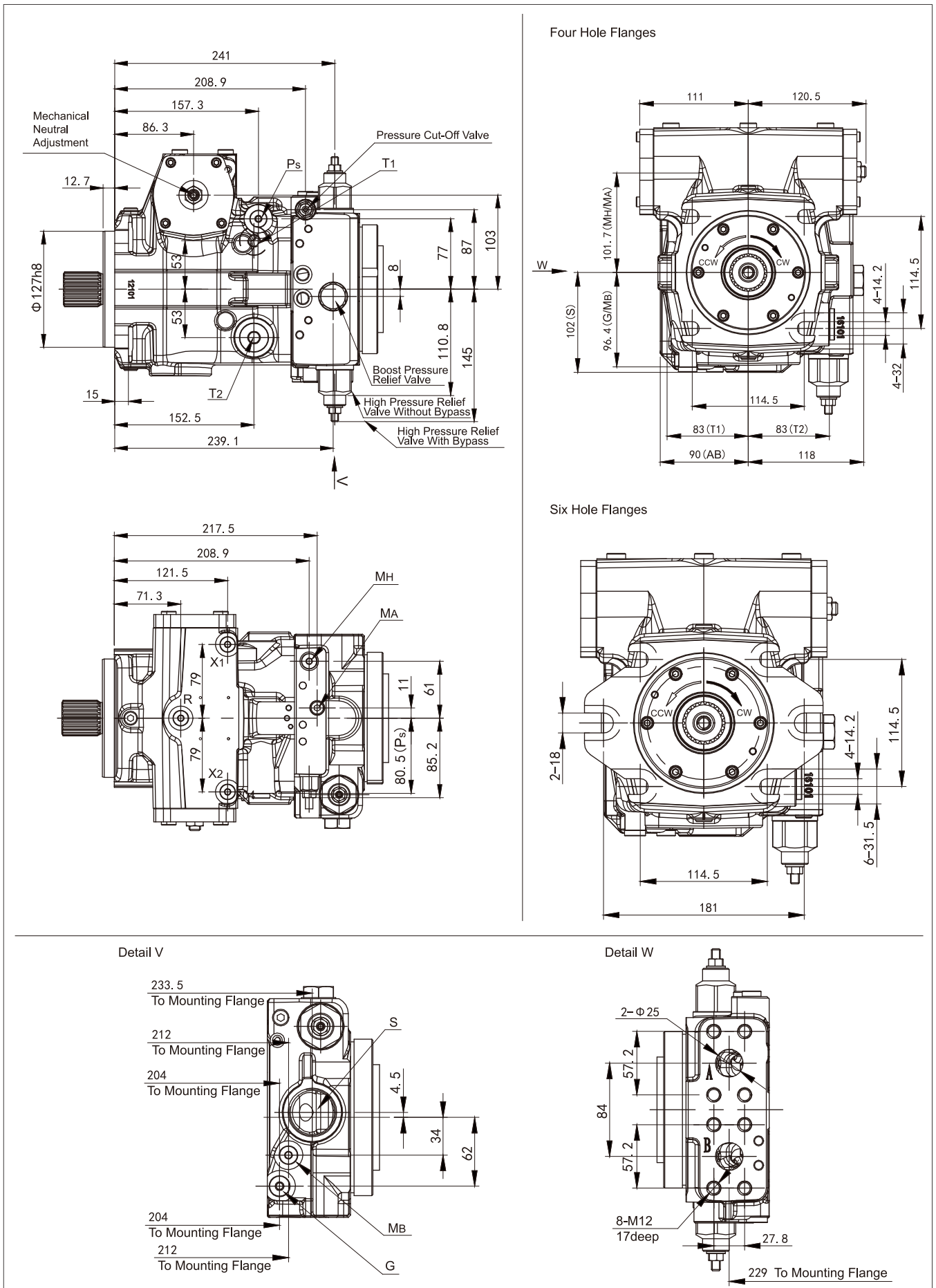



➤ Installation Dimensions-Drive shaft

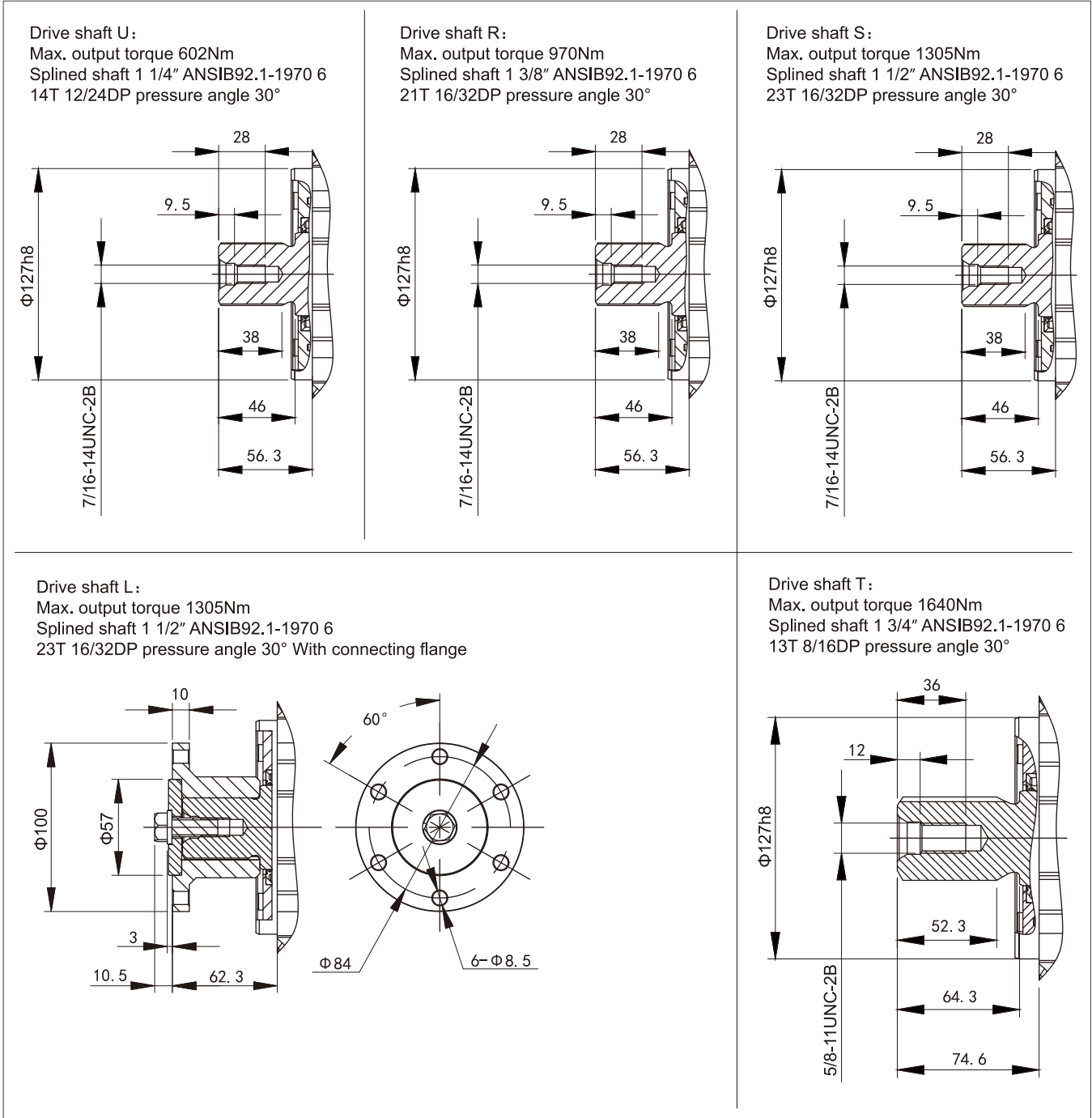



► Installation Dimensions-Port

Port		Standard	Size	P _{max} (bar)	Torque(Nm)	Status ³⁾
A/B	Working port	SAE J518	SAE1"	500	-	○
	Fastening thread	DIN 13	M12×1.75; 17deep	-	5	
S	Suction port	DIN 3852	M42 ×2; 18deep	5	5	○
T ₁ ¹⁾	Drain port		M26×1.5; 16deep	5	5	○
T ₂	Drain port		M26×1.5; 16deep	5	120	×
R	Air bleed post		M12×1.5; 12deep	3	30	
X ₁ /X ₂	Control pressure port		M12×1.5; 12deep	40	30	
X ₃ /X ₄	Chamber pressure port		M12×1.5; 12deep	40	30	
P _s	Inlet of pilot pressure port		M14×1.5; 12deep	40	35	
G	Auxiliary line pressure port		M14×1.5; 12deep	40	35	
MA/MB ²⁾	Pressure measuring oil port for working port		M12×1.5; 12deep	500	30	
MH	Balance high-pressure port		M12×1.5; 12deep	500	30	
F _e	Filter inlet(same side)		-	Φ12	40	
	Filter inlet(opposite side)	DIN 3852	M22×1.5; 14deep	40	80	
F _a	Filter outlet(same side)	-	Φ12	40	-	
	Filter outlet(opposite side)	DIN 3852	M26×1.5; 18deep	40	120	
F _{a1}	Filter auxiliary outlet(opposite side)		M22×1.5; 14deep	40	80	
F _s	Cold start port(opposite side)		M22×1.5; 14deep	5	80	
Y ₁ /Y ₂	Pilot signal port(only HD)		M14×1.5; 10deep	40	5	○

1) The drain port can be provided in different specifications. Please contact our company for details.
2) Same side oil port, rear cover with pressure cutoff function, pressure measurement ports are M12×1.5 and M10×1.5.
3) Status description: O=Must be connected (plugged upon delivery); X= (during normal operation).



Installation Dimensions-Control valve

Mechanical Servo Control-HW¹⁾

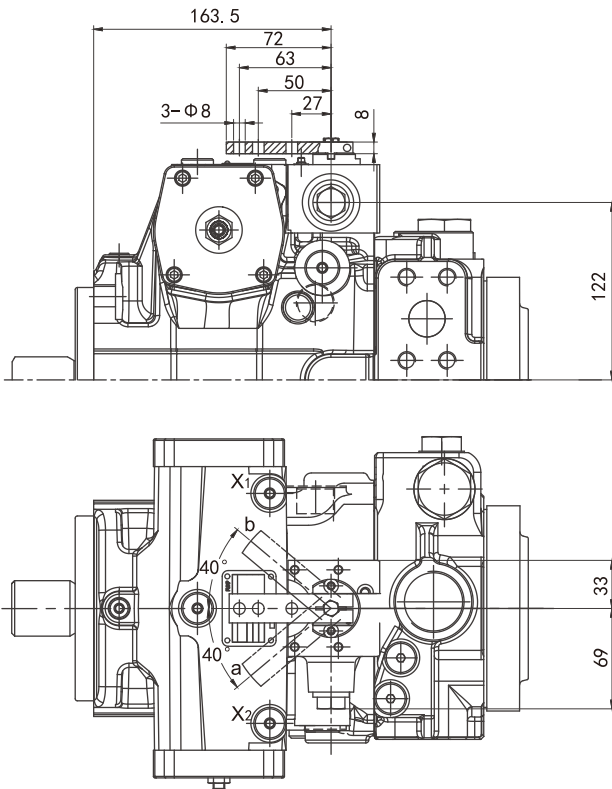

¹⁾Does not show all mechanical handle models. Please contact us for specific models.

With brake valve-HW(O/C)

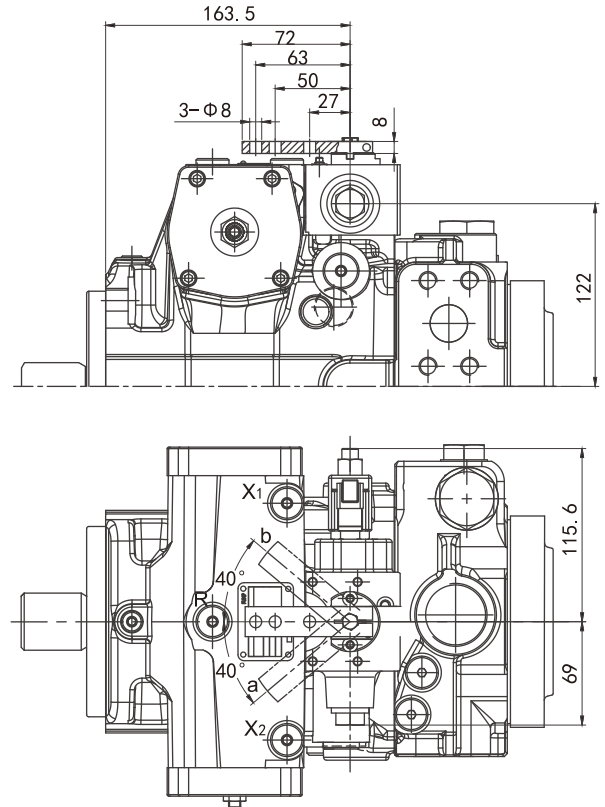

With brake valve and neutral position switch-HW(C/O)L

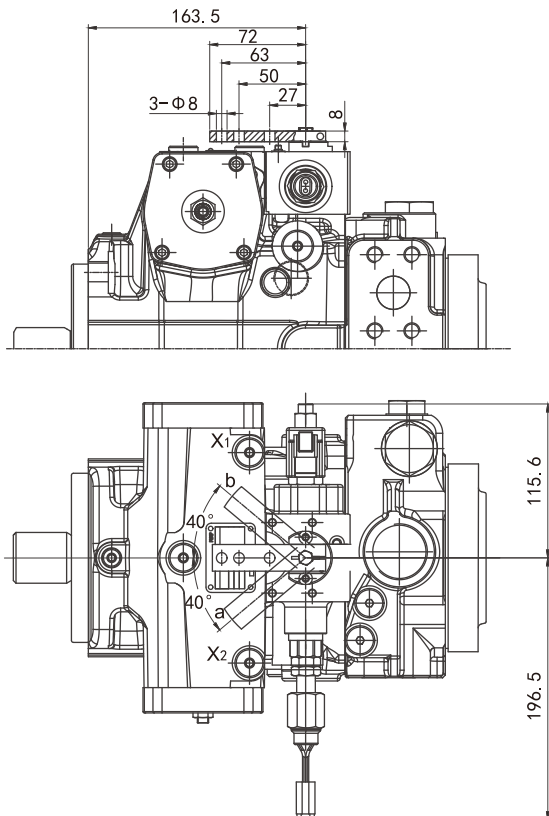

Pilot Pressure Control-HD²⁾

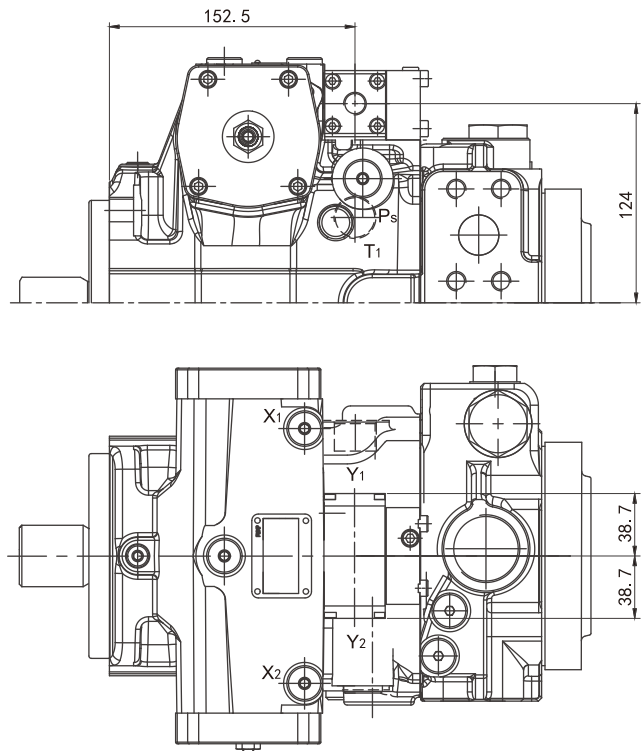

²⁾The size specifications for Y1/Y2 oil ports are detailed in the Oil Port Size Specifications Table.



► Installation Dimensions-Control valve

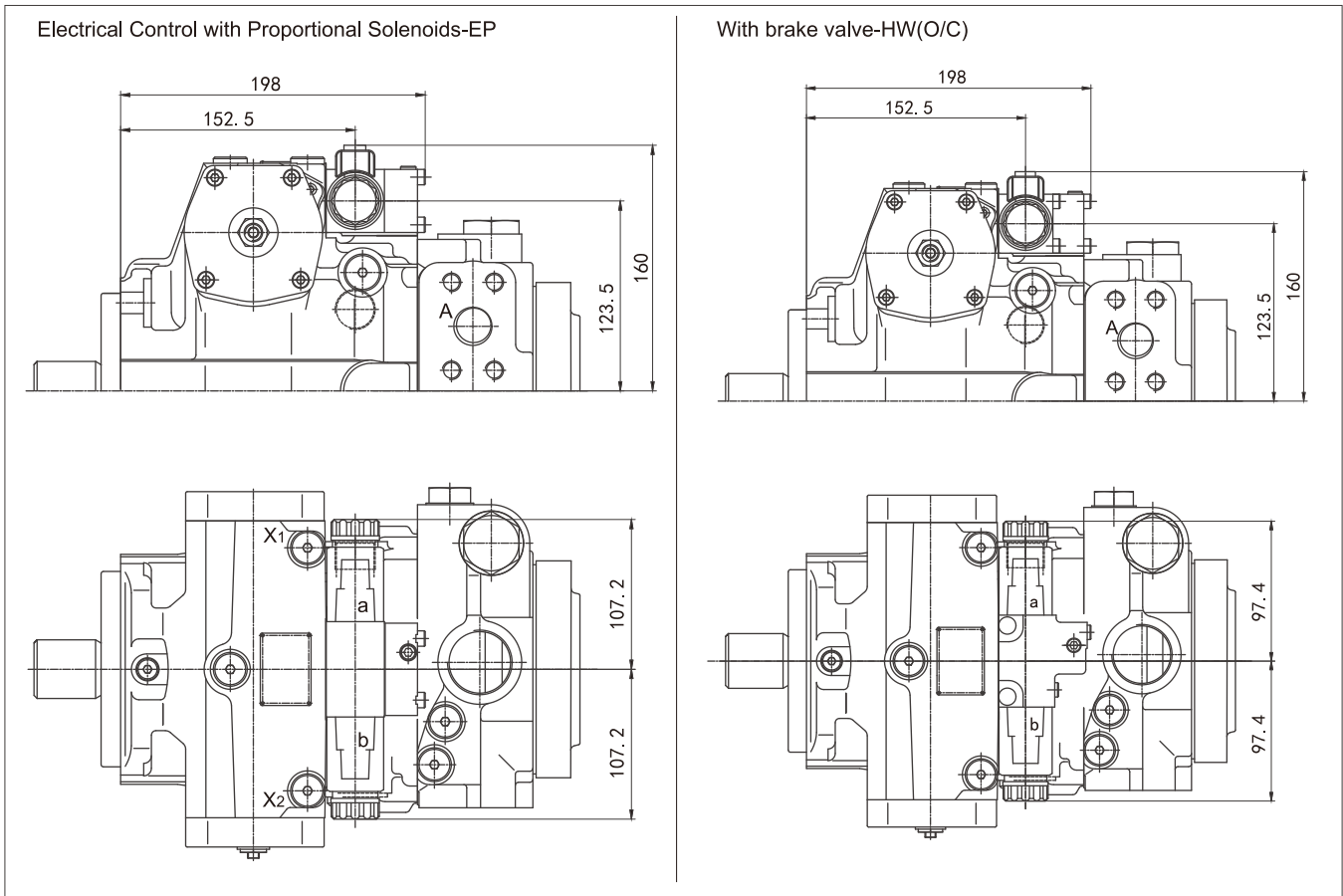



➤ Installation Dimensions-Through drive shaft

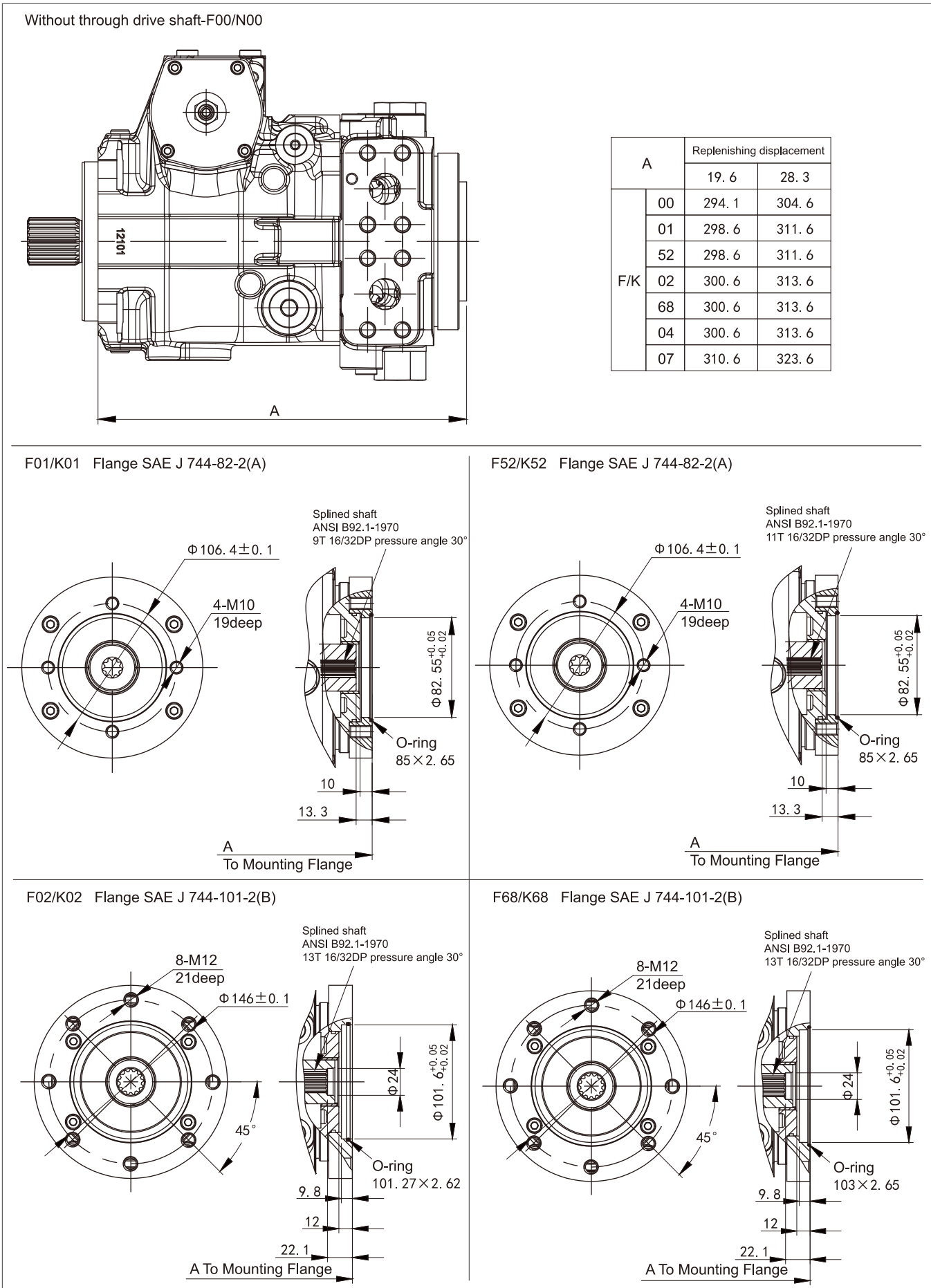



► Installation Dimensions-Through drive shaft

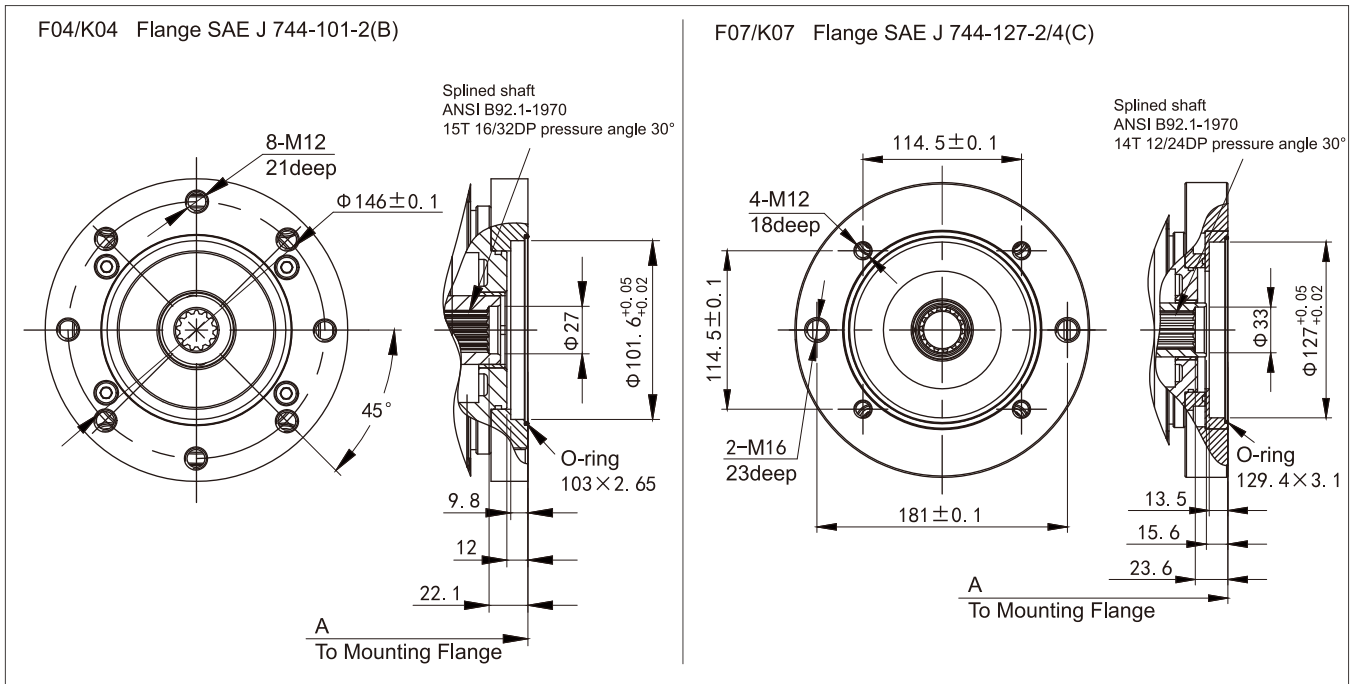



Installation Instructions

General

The axial piston unit must be filled with hydraulic fluid and the air completely exhausted during commissioning and normal operation. Fluid filling and air bleeding are required after long-term shutdown as the hydraulic line of the system may leaks.

The case drain fluid in the case interior must be directed to the reservoir via the highest case drain port. The minimum suction pressure at the suction port must be no less than 0.8bar absolute, and it is no less than 0.5bar absolute at cold start.

The suction line and case drain line must be led into the tank below the lowest level of the tank in the selected working mode.

Installation position

See the examples below. Other installation positions are available upon request.

Note: Describe the “shaft orientation” in the order.

Below-reservoir installation

The pump is installed below the minimum level of the reservoir. Recommended installation positions: 1 and 2.

Above-reservoir installation

The pump is installed above the minimum level of the reservoir, but it does not exceed the maximum allowable suction height $h_{s\max}=800\text{mm}$.

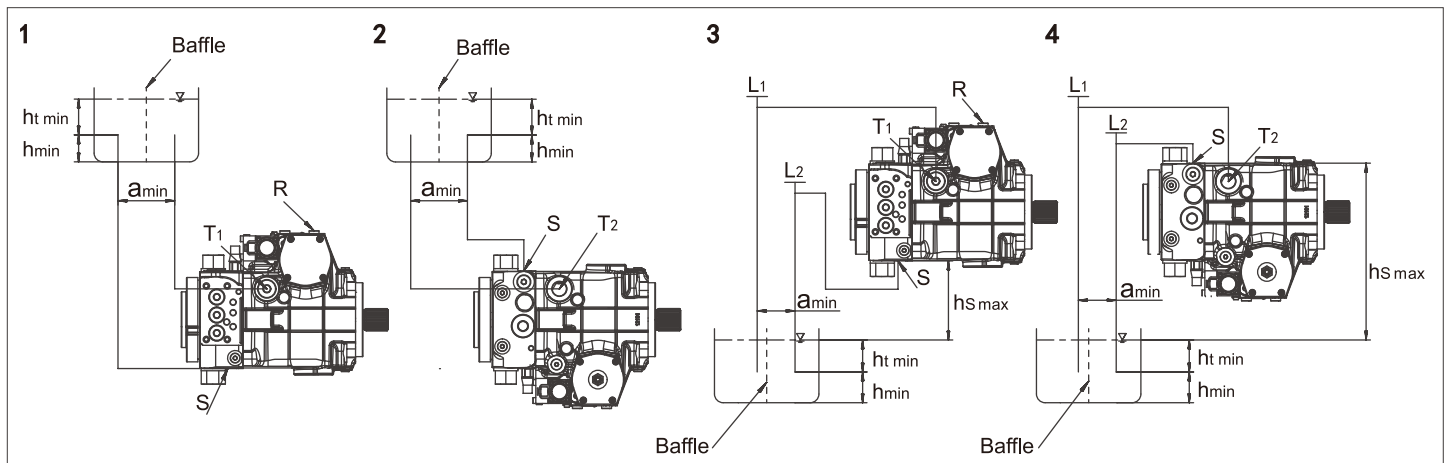

$h_{s\max}=800\text{mm}$, $h_{t\min}=200\text{mm}$, $h_{\min}=100\text{mm}$

When designing the fuel tank, it should be ensured that there is sufficient space before the suction and discharge pipelines a_{\min} , to prevent the heated return oil flow from being directly sucked back into the oil suction pipeline.

Installation Position	Air Bleeding	Filling	Installation Position	Air Bleeding	Filling
1	R	S+T ₁	3	L ₂ (S)+R	L ₂ (S)+L ₁
2	T ₂	S+T ₂	4	L ₂ +L ₂ (T ₂)	L ₂ +L ₁ (T ₂)





Since 2002

Over twenty years of deep cultivation in the field of hydraulic Solutions

HYTEK is a high technology enterprise integrating R&D, production, sales and service of hydraulic power products. Provides professional hydraulic transmission control products and solutions for construction machinery, road machinery, material handling machinery, agricultural and forestry machinery, industrial equipment and other fields.

After more than 20 years of continuous R&D, technological innovation, market development and application services, technical level and the scale of production and sales have been on the forefront of the industry.

Hytek has been committed to helping the development of subdivided industries with innovative hydraulic technology, "focusing on the challenges and pressures of customers, providing competitive products and solutions, reducing costs and increasing efficiency for customers, and continuously creating maximum value".

Product Series

- Open Circuit Pump
- Closed Circuit Pump
- Fixed Displacement Motor
- Variable Displacement Motor
- Hydrostatic Transmission Unit
- Internal Gear Pump
- Vane Pump
- Proportional valve/
Industrial Hydraulic Valve

For more information, please visit our official website and social media:en.hytek.cn



@Hytek Power

HYTEK POWER CO.,LTD.

No. 99, Shengyuan Road, Tengqiao Town, Lucheng District, Wenzhou city 325029, Zhejiang, CHINA

Email: globalsales@hytek.cn

America Canada Germany Italy Russia Türkiye Australia South Korea Thailand India Indonesia South Africa

HYTEK-REV1.0 04/2026

If there are any other modifications, no further notice will be given.