

Axial Piston Variable Motor HA6VM

Series: 63
Size: 28-200 mL/r
Rated pressure: 40 MPa
Max. pressure: 45 MPa

Series: 63
Size: 250 mL/r
Rated pressure: 35 MPa
Max. pressure: 40 MPa

Series: 69
Size: 115/170/215 mL/r
Rated pressure: 40 MPa
Max. pressure: 45 MPa



Features

- Axial piston motor of bent-axis design for hydrostatic drives in open and closed circuits
- Axial tapered piston rotary group
- The output torque increases with the pressure differential between the high- and low-pressure sides and with increasing displacement
- The wide control range allows the variable motor to satisfy the requirements for high speed and high torque
- The displacement can be continuously changed from $V_{g \max}$ to $V_{g \min}=0$
- High cost performance through elimination of gearboxes
- Compact, robust bearing system with long service life
- High power density
- Small moment of inertia and wide motion range of bent axis
- Various control options to realize diverse control and regulation functions

Model Code

	A	B	C	D	J	K	L	M	N	P	R	S	U	V	Y
HA6VM				/		W		—		B			P	—	

Axial piston unit

—	Bent-axis design, variable displacement piston motor	HA6VM
---	--	-------

Displacement

A	Geometric displacement, in mL/r	28	55	80	107	115	160	170	200	215	250	
---	---------------------------------	----	----	----	-----	-----	-----	-----	-----	-----	-----	--

Control device

		28	55	80	107	115	160	170	200	215	250		
B	Proportional Hydraulic control	$\Delta p=1.0\text{MPa}$	●	●	●	●	●	●	●	●	○	HD1	
		$\Delta p=2.5\text{MPa}$	●	●	●	●	●	●	●	●	●	○	HD2
	Two-point hydraulic control		—	—	—	—	—	—	—	—	—	●	HZ
			○	○	○	●	●	●	●	●	●	—	HZ1
			—	●	●	●	●	●	●	●	●	—	HZ3
	Electric control with proportional solenoid	U=12V	●	●	●	●	●	●	●	●	●	○	EP1
		U=24V	●	●	●	●	●	●	●	●	●	○	EP2
	Electric control with switching solenoid	U=12V	○	—	—	●	●	●	●	●	●	○	EZ1
		U=24V	○	—	—	●	●	●	●	●	●	○	EZ2
		U=12V	—	●	●	●	●	●	●	●	●	—	EZ3
		U=24V	—	●	●	●	●	●	●	●	●	—	EZ4
	Automatic control High-pressure related	With minimum pressure increase, $\Delta p=1\text{MPa}$	●	●	●	●	●	●	●	●	●	○	HA1
		With pressure increase, $\Delta p=10\text{MPa}$	●	●	●	●	●	●	●	●	●	○	HA2

Pressure control (for HD/EP/EZ¹⁾/HZ¹⁾)

		28	55	80	107	115	160	170	200	215	250		
C	Without pressure control (without code)		●	●	●	●	●	●	●	●	○		
	Pressure control	Fixed control	●	●	●	●	●	●	●	●	●	○	D
		Two-point hydraulic override control	○	○	○	○	○	○	○	○	○	2)	E
		Hydraulic remote proportional control	—	—	—	—	—	—	—	—	—	○	G

Override control (only for HA)

		28	55	80	107	115	160	170	200	215	250		
D	Without override control (without code)		●	●	●	●	●	●	●	●	○		
	Hydraulic override control/remote control/proportional control		●	●	●	●	●	●	●	●	●	○	T
	Two-point electronic override control	U=12V	○	○	○	○	○	○	○	○	○	—	U1
		U=24V	○	○	○	○	○	○	○	○	○	—	U2

1) : No fixed setting of D for sizes 28 to 80;

2) : Standard configuration with version D.



Model Code

	A	B	C	D		J	K	L		M	N	P	R	S	U	V		Y
HA6VM				/		W		—			B			P		—		

Series

J		28	55	80	107	115	160	170	200	215	250	
	7-piston	●	●	●	●	—	●	—	●	—	●	63
	9-piston	—	—	—	—	●	—	●	—	●	—	69

Direction of rotation (viewed on drive shaft)

K		28	55	80	107	115	160	170	200	215	250	
	Bi-directional	●	●	●	●	●	●	●	●	●	●	W

Setting range for displacement

L		28	55	80	107	115	160	170	200	215	250	
	V _{g min} =0 to 0.7 V _{g max} (without code)	●	●	●	●	●	●	●	●	●	—	
	V _{g min} =0 to 0.4 V _{g max} V _{g max} =V _{g max} to 0.8 V _{g max}	●	●	●	●	●	●	●	●	●	●	○
	V _{g min} >0.4 V _{g max} to 0.8 V _{g max} V _{g max} =V _{g max} to 0.8 V _{g max}	●	●	●	●	●	●	●	●	●	○	2

Sealing material

M		28	55	80	107	115	160	170	200	215	250	
	Fluororubber(FKM)	●	●	●	●	●	●	●	●	●	●	V
	Nitrile rubber (NBR)	●	●	●	●	●	●	●	●	●	●	P

Drive shaft

N		28	55	80	107	115	160	170	200	215	250		
	Splined shaft DIN 5480	●	●	●	●	●	●	●	●	●	●	—	A
		●	●	●	●	●	●	●	●	—	●	●	Z
Parallel keyed shaft DIN 6885	—	—	—	—	—	—	—	—	—	—	○	P	

Mounting flange

P		28	55	80	107	115	160	170	200	215	250	
	4-hole, ISO 3019-2	●	●	●	●	●	●	●	●	●	●	B

Model Code

	A	B	C	D		J	K	L		M	N	P	R	S	U	V		Y
HA6VM					/		W		—			B			P		—	

Working port

		28	55	80	107	115	160	170	200	215	250		
R	Working ports A/B at rear, SAE flange ports, metric fastening thread		●	●	●	●	●	●	●	●	●	010	
		With flushing valve	●	●	●	●	●	●	●	●	●	●	017
	Working ports A/B at opposite sides, SAE flange ports, metric fastening thread		●	●	●	●	●	●	●	●	●	●	020
		With flushing valve	●	●	●	●	●	●	●	●	●	●	027
	Port plate with 1-stage pressure relief valve for mounting a counterbalance valve	BVD, without valve	—	—	—	●	●	—	—	—	—	—	370
			●	●	●	●	●	●	●	○	○	○	380
		BVD, with counterbalance valve	—	—	—	●	●	—	—	—	—	—	378
			○	●	●	●	●	●	●	○	○	○	388
BVD, without valve		○	○	○	○	○	○	○	○	○	○	○	380
		○	○	○	○	○	○	○	○	○	○	○	388

Speed measurement

		28	55	80	107	115	160	170	200	215	250	
S	Without speed sensor(without code)	●	●	●	●	●	●	●	●	●	●	
	With speed sensor(without connector)	●	●	●	●	●	●	●	●	●	●	F
	With speed sensor(DT04-4P connector)	●	●	●	●	●	●	●	●	●	●	F1
	With speed sensor(DTM04-4P connector)	●	●	●	●	●	●	●	●	●	●	F2
	With speed sensor(DTM04-6P connector)	●	●	●	●	●	●	●	●	●	●	F3

Connector for solenoids (for EP/EZ)

		28	55	80	107	115	160	170	200	215	250	
U		●	●	●	●	●	●	●	●	●	●	
	DEUTSCH molded connector, 2-pin, without suppressor diode	●	●	●	●	●	●	●	●	●	●	P

Beginning of control

		28	55	80	107	115	160	170	200	215	250	
V	At $V_{g\ min}$ (standard for HA)	●	●	●	●	●	●	●	●	●	●	A
	At $V_{g\ max}$ (standard for HD/EP/EZ)	●	●	●	●	●	●	●	●	●	●	B

Special configuration

		28	55	80	107	115	160	170	200	215	250	
Y	Without special configuration(without code)	●	●	●	●	●	●	●	●	●	●	
	Special configuration	○	○	○	○	○	○	○	○	○	○	***

● Available ○ On request — Not available

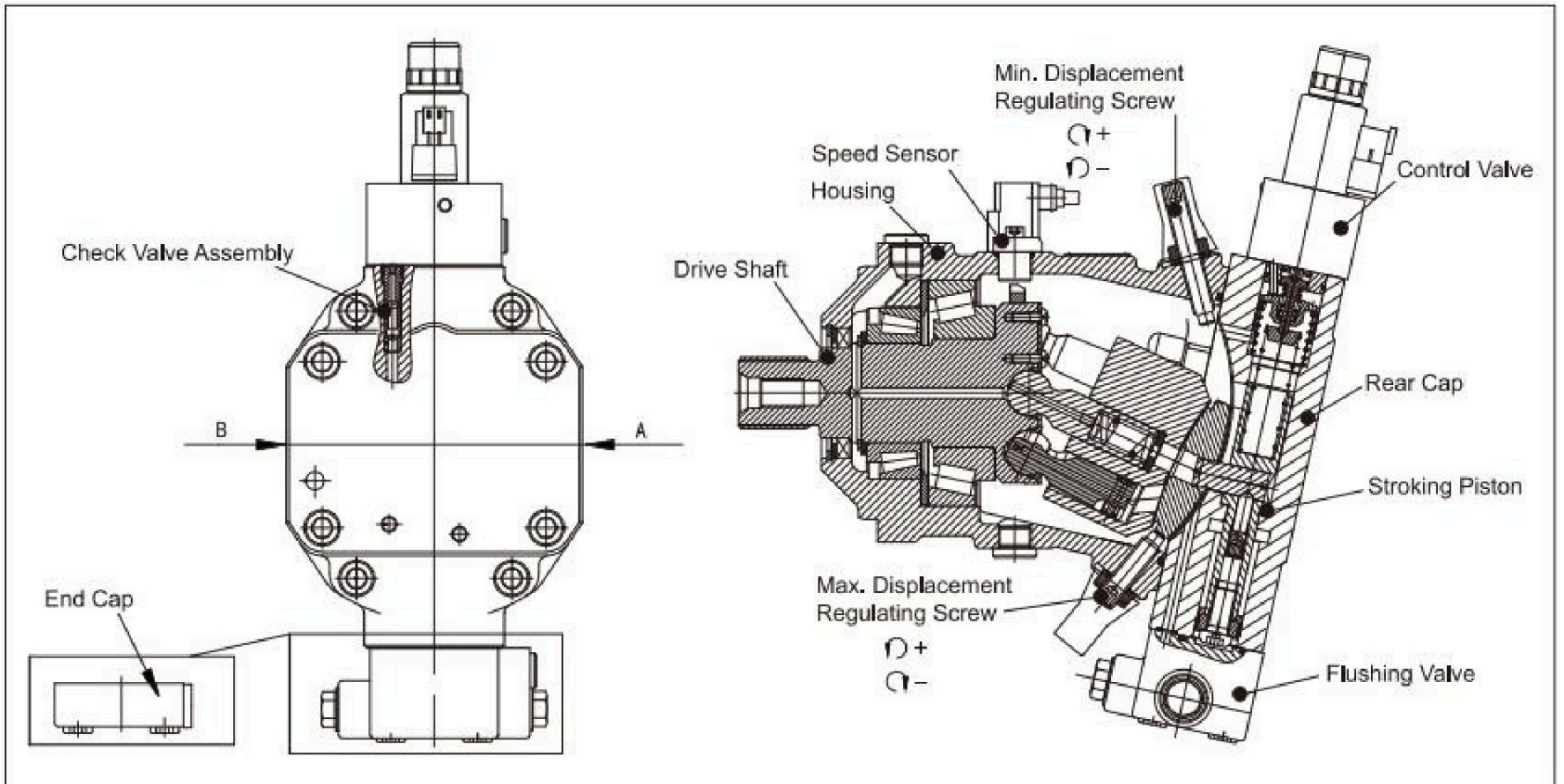



Hydraulic Fluid

Mineral oil

Working Viscosity

In order for the optimum efficiency and service life, it is recommended to select the working viscosity at working temperature within the range below:

$$V_{opt} = \text{optimal working viscosity } 16...36 \text{ mm}^2/\text{s}$$

It is subject to the circuit temperature of a closed circuit and the reservoir temperature of an open circuit.

Limit Viscosity

Limit Viscosity:

$$V_{min} = 5 \text{ mm}^2/\text{s}$$

Short-term operation ($t < 3 \text{ min}$),

permissible maximum temperature $t_{max} = +115^\circ\text{C}$

$$V_{max} = 1600 \text{ mm}^2/\text{s}$$

Short-term operation ($t < 3 \text{ min}$),

Cold start ($p \leq 3 \text{ MPa}$, $n \leq 1000 \text{ rpm}$, $t_{min} = -40^\circ\text{C}$)

Selection Diagram

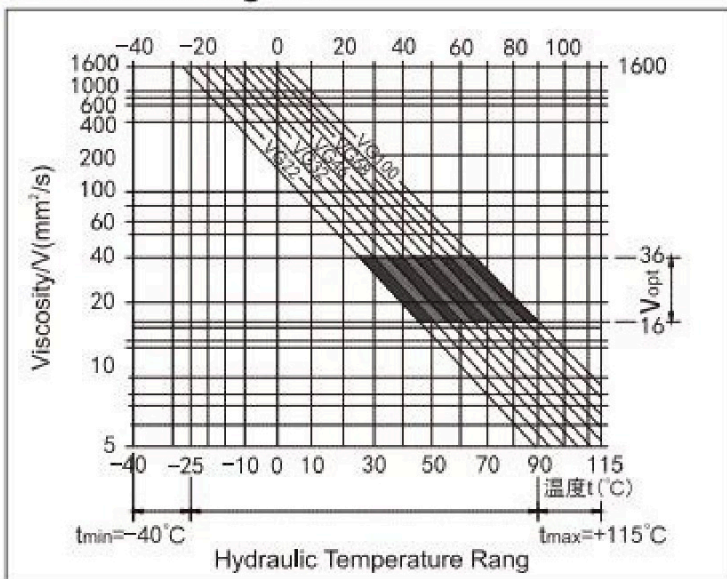

Instructions on Selection of Hydraulic Fluid

The working temperature dependent on the ambient temperature is required for correct selection of hydraulic fluid. It refers to the circuit temperature of a closed circuit and the reservoir temperature of an open circuit.

The hydraulic fluid should be so selected that the working viscosity in the working range is within the optimum range (V_{opt} , the shaded area on the selection diagram). The higher viscosity is recommended in all applications.

For example: At an ambient temperature of $X^\circ\text{C}$, the working temperature of the circuit is 60°C . The viscosity within the optimum range (V_{opt} , shaded area) is VG46 or VG68 and the latter should be selected.

Note: The case drain temperature depends on the pressure and speed, and it is always higher than the circuit temperature. The temperature at any point within the system should not exceed $+115^\circ\text{C}$.

If the above condition cannot be maintained due to extreme working conditions, it is recommended to flush the housing via port U or through the flushing and boost-pressure valve.

Filtration

Finer filtration improves the cleanliness level of the hydraulic fluid, thus increasing the service life of the axial piston unit. To ensure normal operation of the axial piston unit, a cleanliness level of at least 20/18/15 according to ISO 4406 is to be maintained.

When the hydraulic fluid has a high temperature (90°C to 115°C), the cleanliness level should at least reach 19/17/14 according to ISO 4406. Please contact us if the above cleanliness level cannot be reached.

Working Pressure Range

63/69 series

Max. pressure at port A or B
 Rated pressure P_N _____ 40MPa
 Maximum pressure P_{max} _____ 45MPa
 Total pressure (pressure A + pressure B) P_{max} _____ 70MPa

69 series-Displacement 250

Max. pressure at port A or B
 Rated pressure P_N _____ 35MPa
 Maximum pressure P_{max} _____ 40MPa
 Total pressure (pressure A + pressure B) P_{max} _____ 70MPa

Note: For Z type drive shaft, the permissible nominal pressure P_N is 31.5MPa if there is radial load (gear and V-belt) on the drive shaft of the drive unit.

Flow Direction

Direction of rotation, viewed on drive shaft

CW	CCW
A to B	B to A

No limit to minimum speed n_{min} .

If uniformity of motion is required, n_{min} must not be less than 50rpm.

Shaft Seal

Permissible pressure load

The service life of the shaft seal depends on the motor speed and case drain pressure. It is recommended that the average lasting case drain pressure at working temperature is no greater than 0.3MPa absolute pressure (as the speed falls, the maximum permissible case drain pressure is 0.6MPa) and the short-term ($t < 0.1 \text{ s}$) permissible absolute pressure peak may reach 1 MPa. The service life of the shaft seal decreases with increasing frequency of pressure peaks.

The case pressure must be equal to or greater than the external pressure at the shaft seal.

Temperature Range

The FKM shaft seal may be used for case temperatures from -25°C to $+115^\circ\text{C}$.

In applications below -25°C , an NBR seal is required (permissible temperature range: -40°C to $+90^\circ\text{C}$).

Effect of Case Pressure on Beginning of Control

An increase in case pressure affects the following control options at the beginning of control of the variable motor:

HA1T _____ increase
 HD/HA/HA,T/EP _____ increase
 The factory settings for the beginning of control are made at $P_{abs} = 0.2 \text{ MPa}$.



Technical Data

Size	63 Series		Unit	28	55	80	107	160	200	250
Displacement		$V_{g \max}$	mL/r	28.1	54.8	80	107	160	200	250
		V_{g0}	mL/r	0	0	0	0	0	0	0
Maximum speed	In compliance with maximum permissible flow	n_{\max} at $V_{g \max}$	rpm	5500	4450	3900	3550	3100	2900	2700
		$n_{\max 1}$ at $V_g < V_{g \max}$	rpm	8750	7000	6150	5600	4900	4600	3600
		$V_g = 0.63 \times V_{g \max}$	mL/r	18	35	51	68	101	126	158
		$n_{\max 0}$ at V_{g0}	rpm	10450	8350	7350	6300	5500	5100	3600
Max. flow		$q_{v \max}$	L/min	156	244	312	380	496	580	675
Max. torque		T_{\max} at $V_{g \max}$	Nm	179	349	509	681	1019	1273	–
Rotary stiffness			Nm/°	–	700	1150	1560	2320	2910	–
Moment of inertia of drive shaft		J	kgm ²	0.0014	0.0042	0.0080	0.0127	0.0253	0.0353	0.061
Case volume		V	L	0.5	0.75	1.2	1.5	2.4	2.7	3.0
Weight		m	kg	16	26	34	47	64	80	100

Size	69 Series		Unit	115	170	215
Displacement		$V_{g \max}$	mL/r	115.6	171.8	216.5
		V_{g0}	mL/r	0	0	0
Maximum speed	In compliance with maximum permissible flow	n_{\max} at $V_{g \max}$	rpm	3550	3100	2900
		$n_{\max 1}$ at $V_g < V_{g \max}$	rpm	6150	4900	4600
		$V_g = 0.63 \times V_{g \max}$	mL/r	73	108	137
		$n_{\max 0}$ at V_{g0}	rpm	7350	5750	5500
Max. flow		$q_{v \max}$	L/min	410	533	628
Max. torque		T_{\max} at $V_{g \max}$	Nm	828	1230	1550
Rotary stiffness			Nm/°	–	–	–
Moment of inertia of drive shaft		J	kgm ²	0.0110	0.0213	0.0303
Case volume		V	L	1.5	2.3	2.8
Weight		m	kg	46	62	78

➤ **MINIMUM INLET PRESSURE at working Port A(B)**

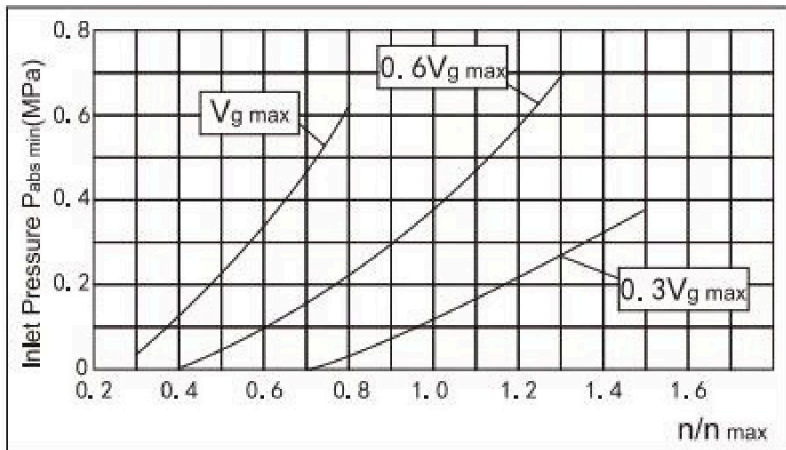

To prevent damage to the variable motor, a minimum inlet pressure must be ensured at the inlet.

This minimum inlet pressure depends on the speed and swivel angle (displacement) of the variable motor.

➤ **Permissible Displacement in Relation to Rotational Speed**

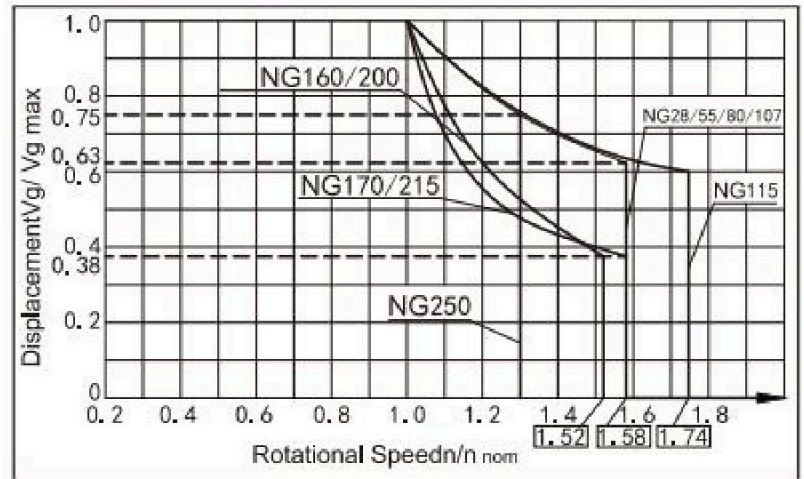

➤ **Permissible Radial and Axial Forces of Drive Shaft**

Size			28	55	80	107	115	160	170	200	215	250
Max. radial force at distance a from shaft collar ¹⁾ 	$F_q\ max$	N	-	10440	13114	15278	16727	20320	21220	22896	25016	-
	a	mm	-	15	17.5	20	22.5	22.5	25	25	27.5	-
Permissible torque	T_{max}	Nm	179	349	509	681	828	1019	1230	1273	1445	-
Max. axial force ²⁾ 	$-F_{ax\ max}$	N	315	500	710	900	900	1120	1120	1250	1250	1200
	$+F_{ax\ max}$	N	315	500	710	900	900	1120	1120	1250	1250	1200
Permissible axial force/bar Working pressure/bar	F_{ax}/bar	N/bar	4.6	7.5	9.6	11.3	11.3	15.1	15.1	17.0	17.0	-

1) : Intermittent operation ;

2) : Max. permissible axial force when the axial piston motor is stationary or working under no pressure.

➤ **Specification Calculation**

Input flow $q_v = \frac{V_g \cdot n}{1000 \cdot \eta_v}$ [L/min]

Torque $T = \frac{V_g \cdot \Delta p \cdot \eta_{mh}}{2 \cdot \pi}$ [Nm]

Power $P = \frac{2\pi \cdot T \cdot n}{60000} = \frac{q_v \cdot \Delta p \cdot \eta_t}{60}$ [KW]

Speed $n = \frac{q_v \cdot 1000 \cdot \eta_v}{V_g}$ [rpm]

V_g = Displacement, mL/r

Δp = Differential pressure, MPa

n = Speed, rpm

η_v = Volumetric efficiency

η_{mh} = Mechanical-hydraulic efficiency

η_t = Total efficiency



Control Device-HD Proportional Hydraulic Control

The hydraulic system related to pilot pressure allows infinite change of motor displacement with pilot pressure signal. The displacement is proportional to the pilot pressure at port X.

Standard configuration:

- Beginning of control at $V_{g \max}$ (max. torque, min. speed)
- End of control at $V_{g \min}$ (min. torque, max. permissible speed)

Note:

- Maximum permissible pilot pressure=10MPa
- For stable control, a working pressure of at least 3MPa is required at port A(B). If control is made at a working pressure below 3MPa, an auxiliary pressure of at least 3MPa must be applied at port G using an external check valve. Lower pressures may be needed in certain cases.
- Specify the setting of beginning of control in plain text when ordering, e.g.: beginning of control = 1MPa.

HD1 pilot pressure increase $\Delta p_s=1\text{MPa}$

A pilot pressure increase of 1MPa at port X will cause displacement to fall from $V_{g \max}$ to 0mL/r.

Beginning of control (setting range) _____ 0.2-2MPa

Standard setting: beginning of control at 0.3MPa (end of control at 1.3MPa)

HD1 Characteristic curve

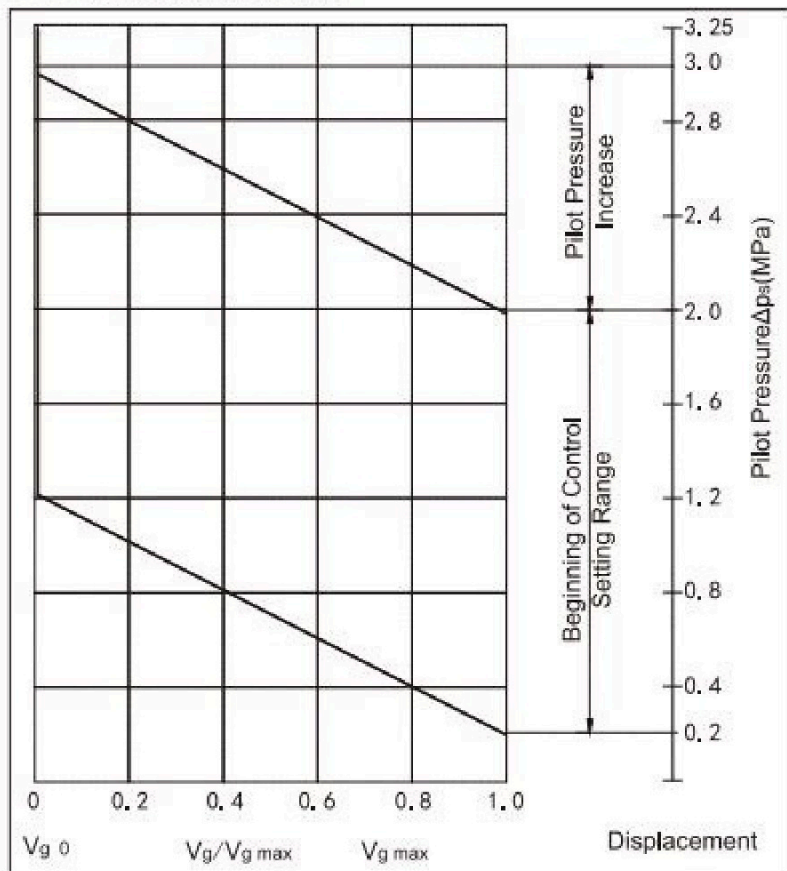

HD2 pilot pressure increase $\Delta p_s=2.5\text{MPa}$

A pilot pressure increase of 2.5MPa at port X will cause displacement to fall from $V_{g \max}$ to 0mL/r.

Beginning of control (setting range) _____ 0.5-5MPa

Standard setting: beginning of control at 1MPa (end of control at 3.5MPa)

HD2 Characteristic curve

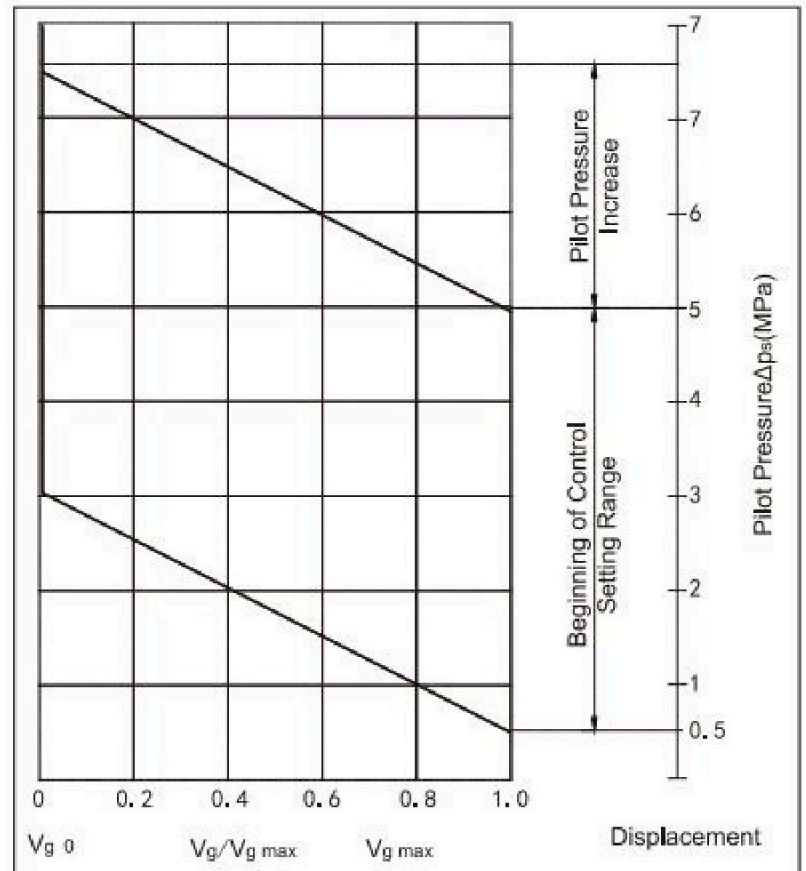

HD1/HD2 Hydraulic control circuit diagram

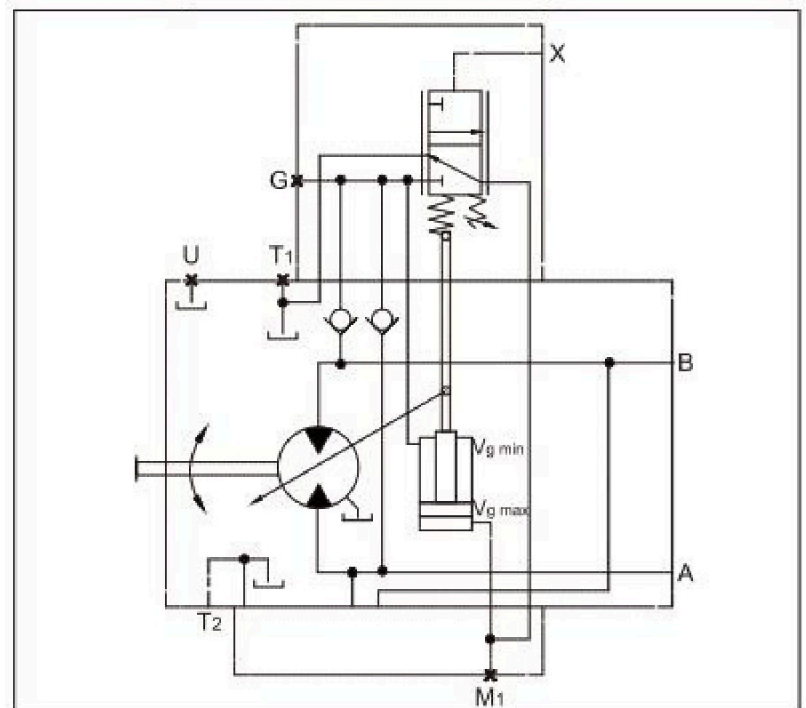

Note

The returning spring in the control device does not serve as a safety device. In the case of internal contamination (e.g. impurities in hydraulic fluid, worn system components or residual pollutant), the control spool and/or positioning piston may get stuck in any position. This may cause failure of the variable motor to provide the required speed and torque.

- Install a suitable emergency stop to ensure safety of the driven load (e.g. prompt stop).
- Maintain a cleanliness level of 20/18/15 (<90 °C) or 19/17/14 (>90 °C) according to ISO 4406.



HD.D Pressure Control, Fixed Setting

Pressure control overrides HD functions. If the load torque or a reduction in motor swivel angle causes the system pressure to rise and reach the set point of the pressure control, the motor will swivel towards a larger angle.

The increase in displacement and reduction in pressure cause the control deviation to decrease. By increasing the displacement, the motor develops more torque at constant pressure.

Setting range of pressure control valve: 8-40 MPa

HD.D Hydraulic control circuit diagram-displacement 28-215

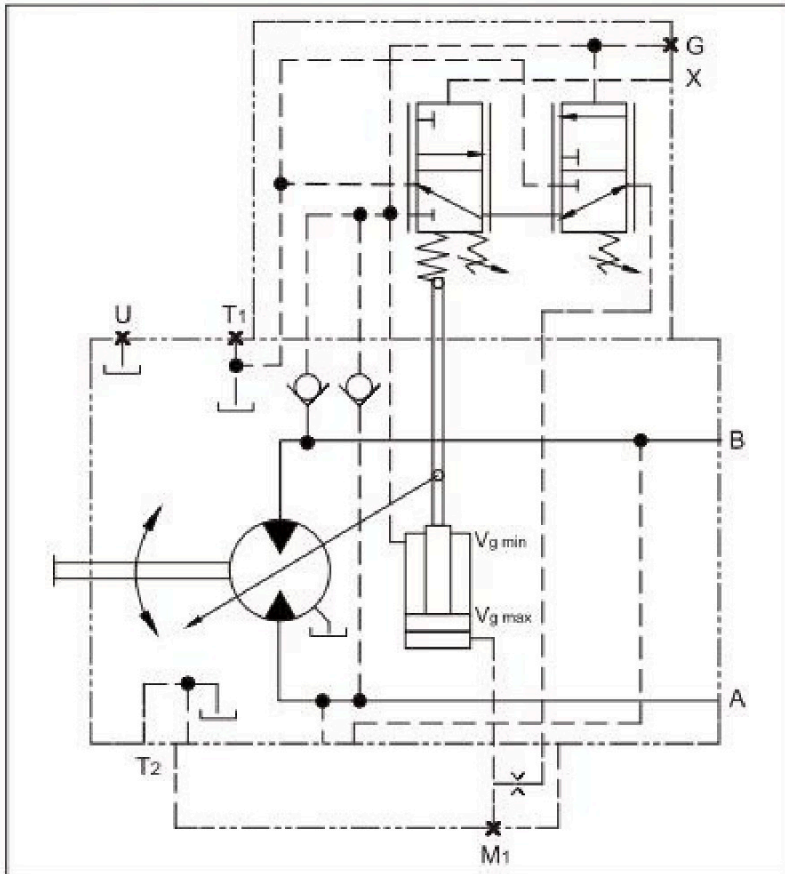

HD.D Hydraulic control circuit diagram-displacement 250

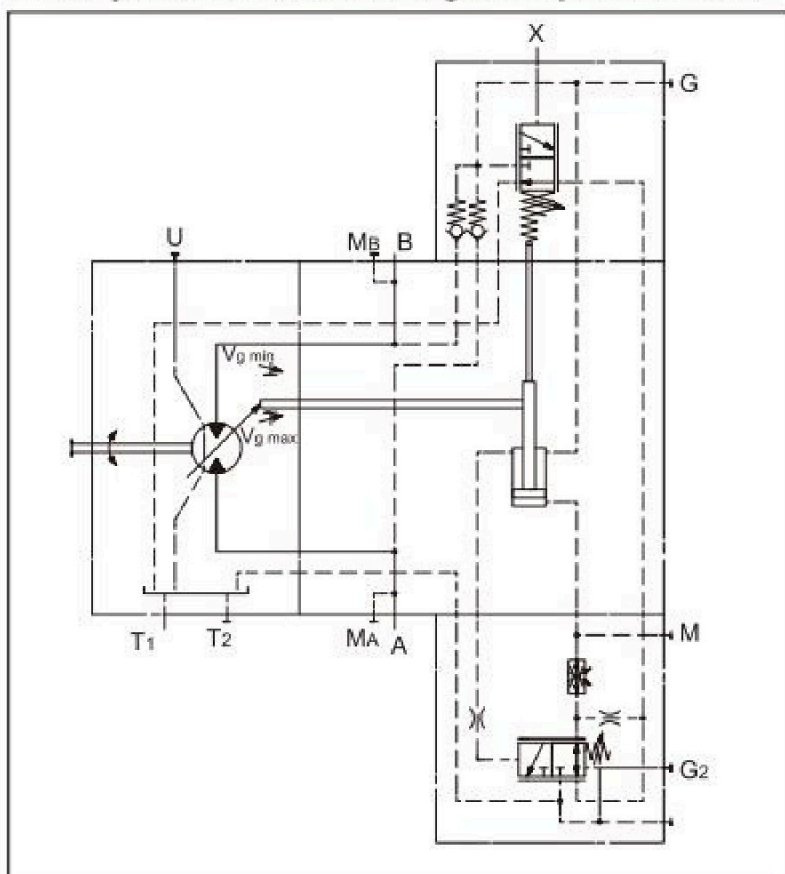

HD.E Pressure Control, Two-point Hydraulic Override Control

The pressure control setting may be overridden by applying an external pilot pressure at port G2, realizing a 2nd pressure setting.

Pilot pressure required at port G2: $P_{st} = 2-5\text{MPa}$

Please specify the 2nd pressure setting in plain text when ordering.

HD.E Hydraulic control circuit diagram-displacement 28-215

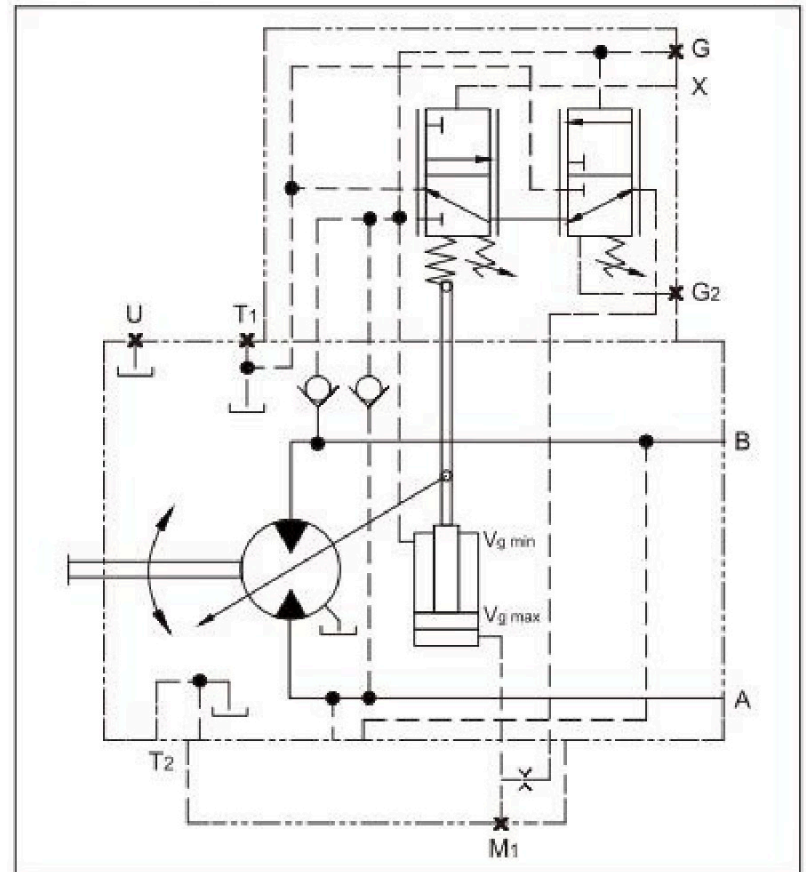

HD.D displacement 250

Pressure control with 2nd pressure setting for HD.D is provided as standard (see proportional hydraulic control, HD).

The pressure control setting may be overridden by applying an external pilot pressure at port G2, realizing a 2nd pressure setting.

Pilot pressure required at port G2: $P_{st} \geq 10\text{MPa}$

Please specify the 2nd pressure setting in plain text when ordering.



HD.G Pressure Control, Hydraulic Proportional Remote Control

When the set pressure value is reached, the remote pressure control system continuously regulates the motor until the maximum displacement $V_{g \max}$ is reached. The pressure relief valve which is located separately from the motor and connected to port X_3 assumes the task of controlling the internal pressure cut-off valve. As long as the target pressure value has not been reached, pressure is evenly applied to the valve from both sides (in addition to the spring force), and the valve remains closed. The target pressure is between 8MPa and 35MPa. When the separate pressure relief valve reaches the target pressure, the valve opens, resetting the pressure on the spring side of the reservoir. The internal control valve and the motor switch to the maximum displacement $V_{g \max}$. The standard differential pressure at the control valve is set to 2.5MPa.

HD.G Hydraulic control circuit diagram-displacement 250

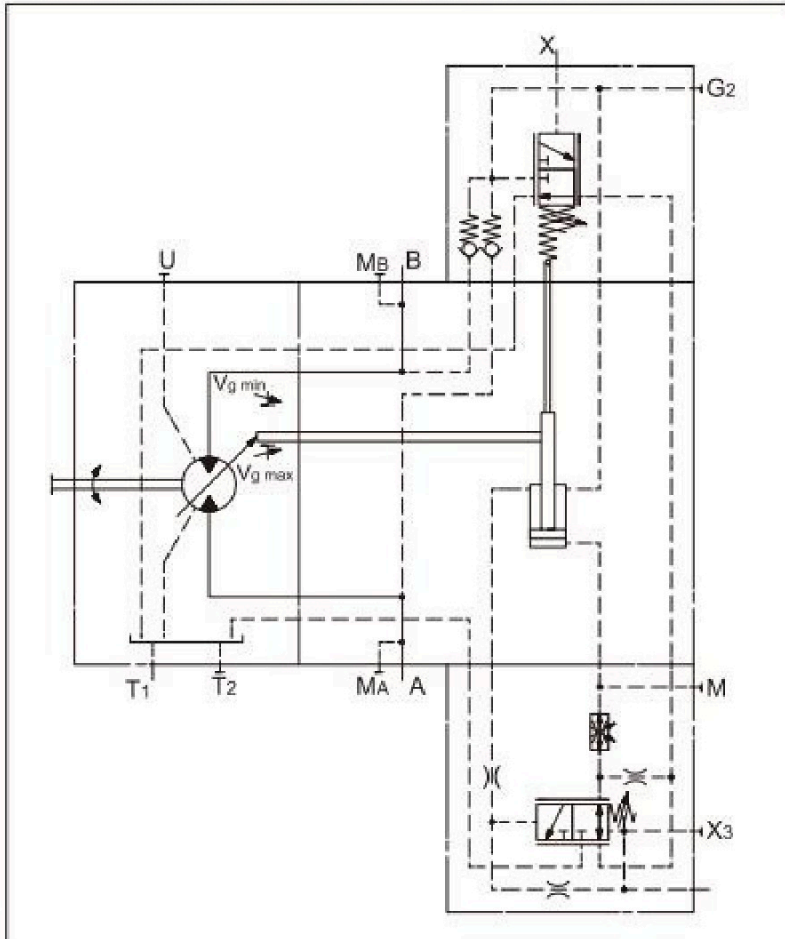



Control Device - HZ Two-point hydraulic control

The two-point hydraulic control allows the displacement to be set to $V_{g \min}$ or $V_{g \max}$ by switching on or off the pilot pressure at port X.

Standard configuration:

- Beginning of control at $V_{g \max}$
(without pilot pressure, max. torque, min. speed)
- End of control at $V_{g \min}$
(pilot pressure > 1MPa, min. torque, max. speed)

HZ Characteristic curve

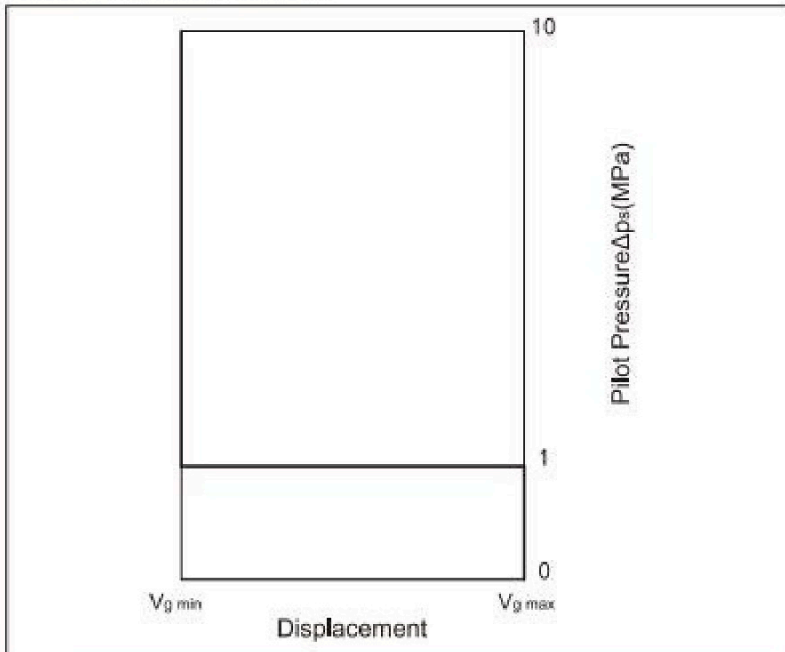

Note

- Maximum permissible pilot pressure $\Delta p_s = 10 \text{ MPa}$
- For stable control, a working pressure of at least 3MPa is required at port A(B). If control is made at a working pressure below 3MPa, an auxiliary pressure of at least 3MPa must be applied at port G using an external check valve. For lower pressures, please contact us;
- Please note that a pressure up to 45MPa can occur at port G

HZ Hydraulic control circuit diagram-displacement 250

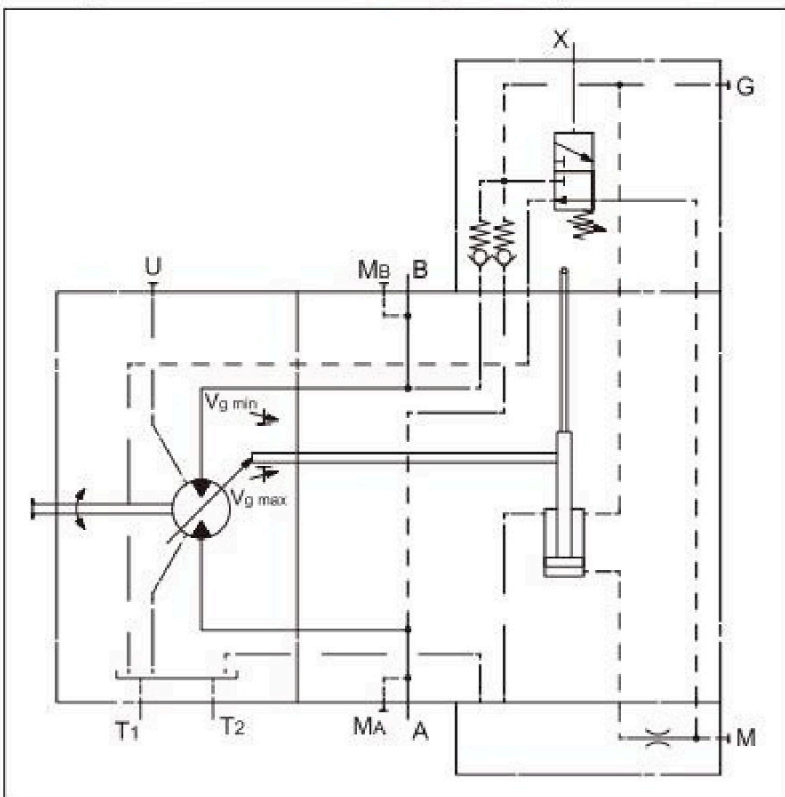

HZ1 Hydraulic control circuit diagram-displacement 28-215

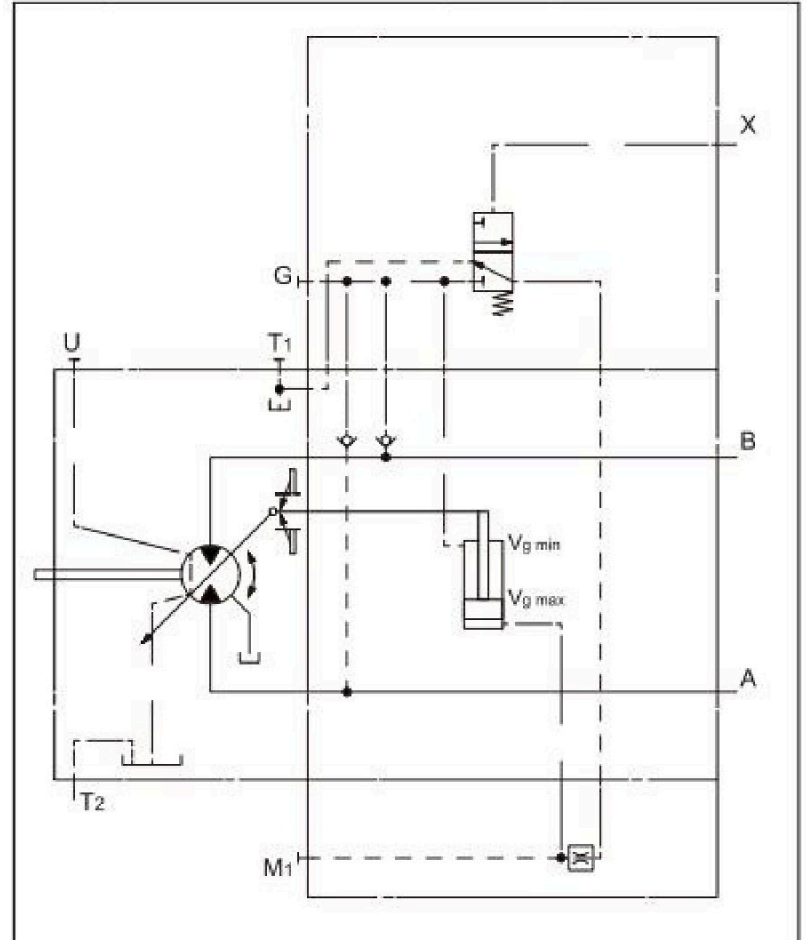

HZ3 Hydraulic control circuit diagram-displacement 28-215

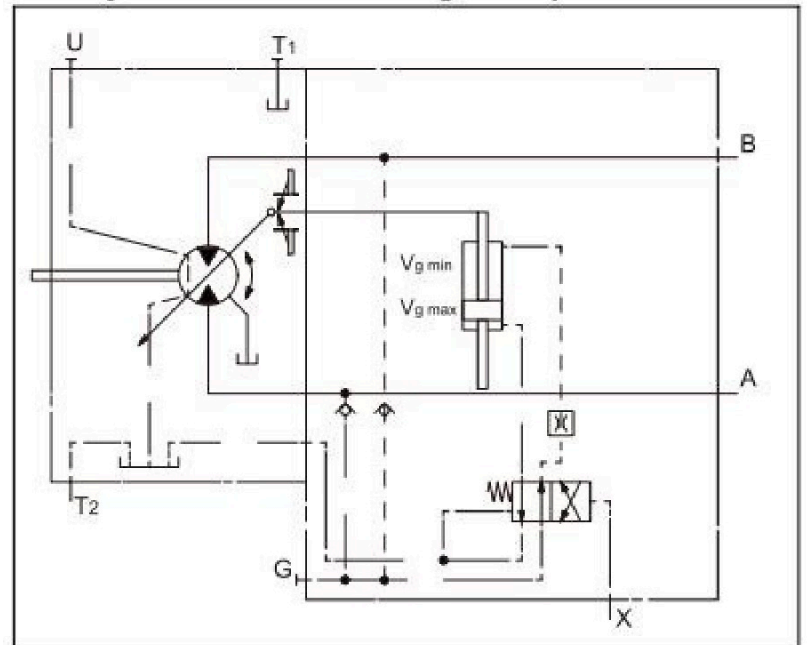



➤ HZ3.D Two-point Hydraulic Control, Fixed Control

Pressure control overrides HZ functions. If the load torque or a reduction in motor swivel angle causes the system pressure to rise and reach the set point of the pressure control, the motor will swivel towards a larger angle. The increase in displacement and reduction in pressure cause the control deviation to decrease. By increasing the displacement, the motor develops more torque at constant pressure.

Setting range of pressure control valve: 8-40MPa

HZ3/HZ3.D Hydraulic control circuit diagram-displacement 107-215

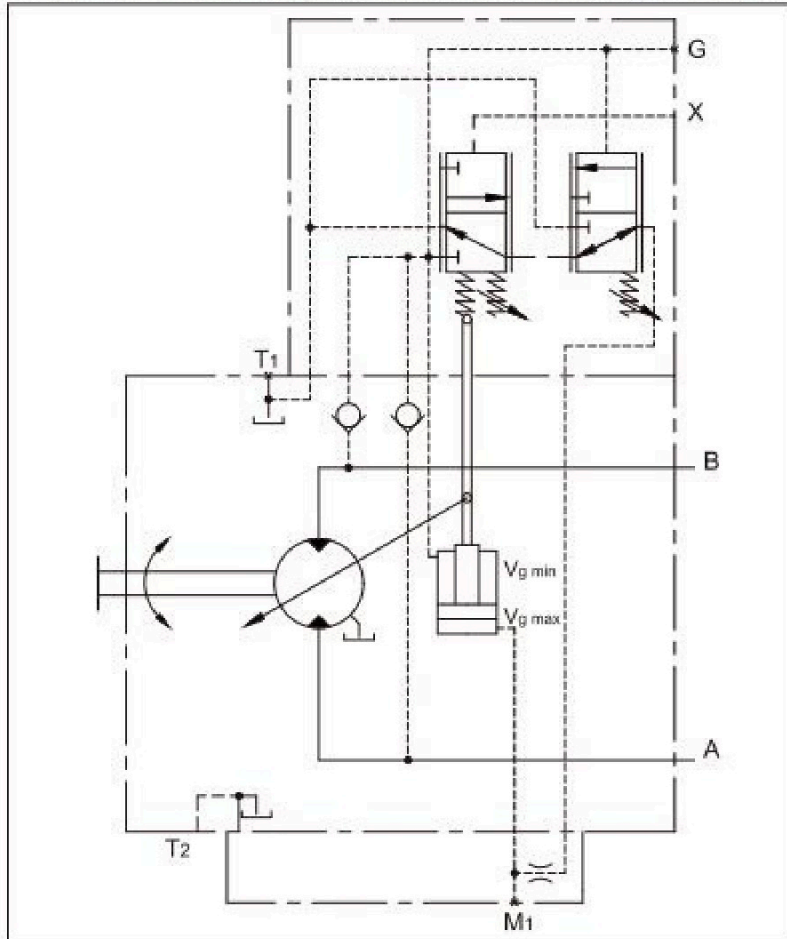



Control Device-EP Electric Control with Proportional Solenoid

The electric control with proportional solenoid allows infinite setting of motor displacement with electric signals. Control is proportional to the current applied to the solenoid.

Standard configuration:

- Beginning of control at $V_{g \max}$ (max. torque, min. speed)
- End of control at $V_{g \min}$ (min. torque, max. permissible speed)

EP Characteristic curve

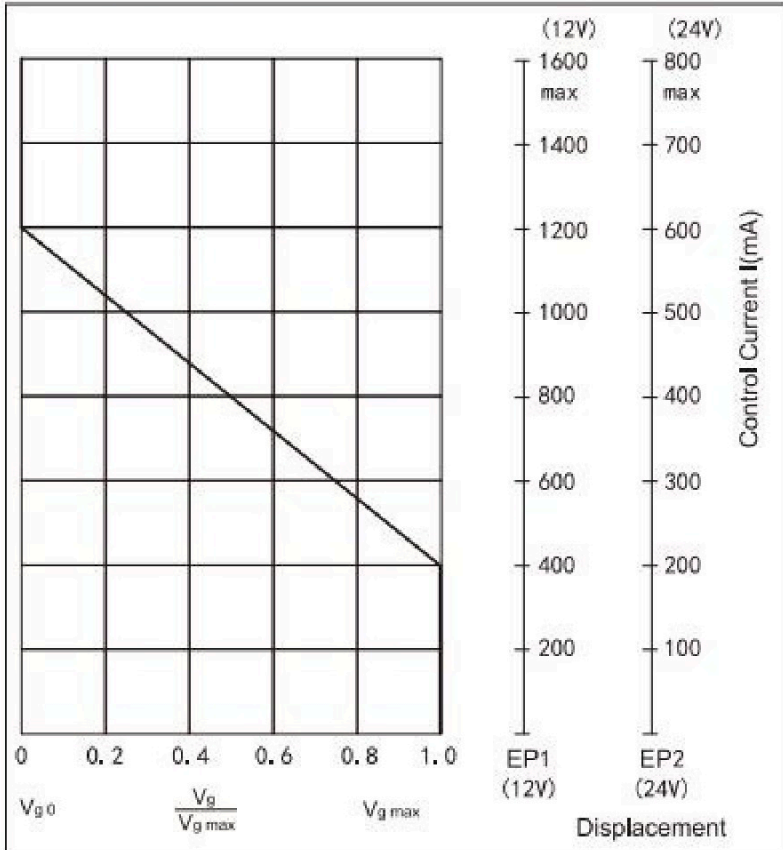

Note

For stable control, a working pressure of at least 3 MPa is required at port A(B). If control is made at a working pressure < 3 MPa, an auxiliary pressure of at least 3 MPa must be applied at port G using an external check valve. Lower pressures may be needed in certain cases.

Technical data, EP1/EP2 solenoid

	EP1	EP2
Voltage	12V (±20%)	24V (±20%)
Control current		
Beginning of control at $V_{g \max}$	400mA	200mA
Beginning of control at $V_{g \min}$	1200mA	600mA
Current limit	1.54A	0.77A
Nominal resistance(20°C)	5.5Ω	22.7Ω
Dither frequency	100Hz	100Hz
Duty cycle	100%	100%
Type of protection	IP65	

The returning spring in the control device does not serve as a safety device.

In the case of internal contamination (e.g. impurities in hydraulic fluid, worn system components or residual pollutant), the control spool and/or positioning piston may get stuck in any position. This may cause failure of the variable motor to provide the required speed and torque.

- Install a suitable emergency stop to ensure safety of the driven load (e.g. prompt stop)
- Maintain a cleanliness level of 20/18/15 (<90 °C) or 19/17/14 (>90 °C) according to ISO 4406

EP1/EP2 Hydraulic control circuit diagram-displacement 28-215

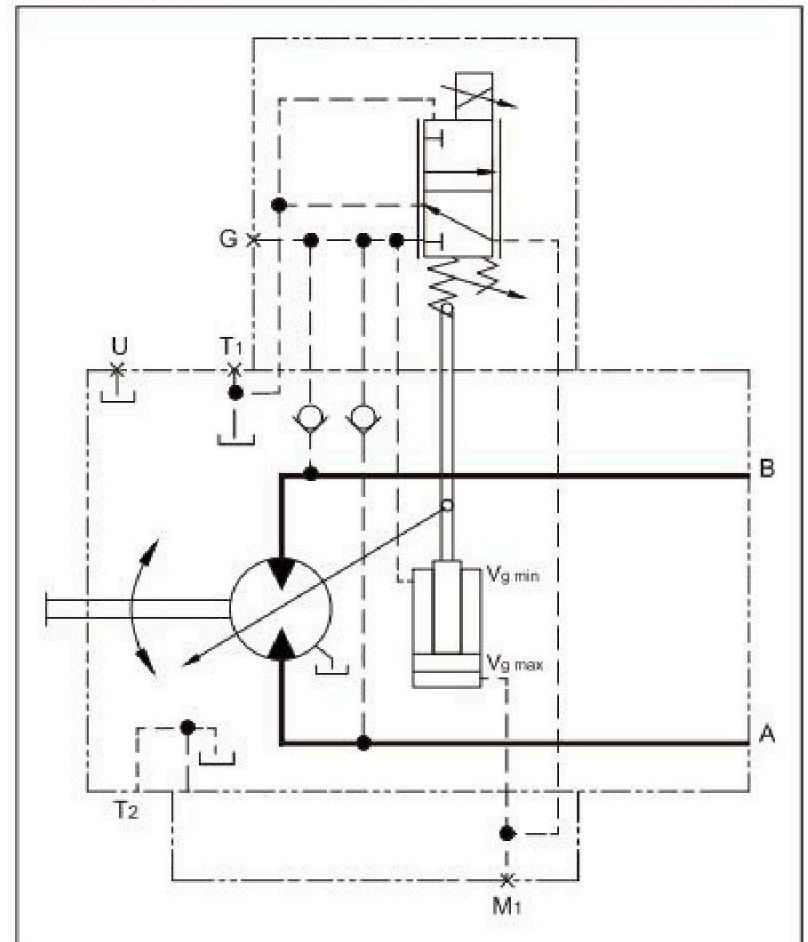

EP1/EP2 Hydraulic control circuit diagram-displacement 250

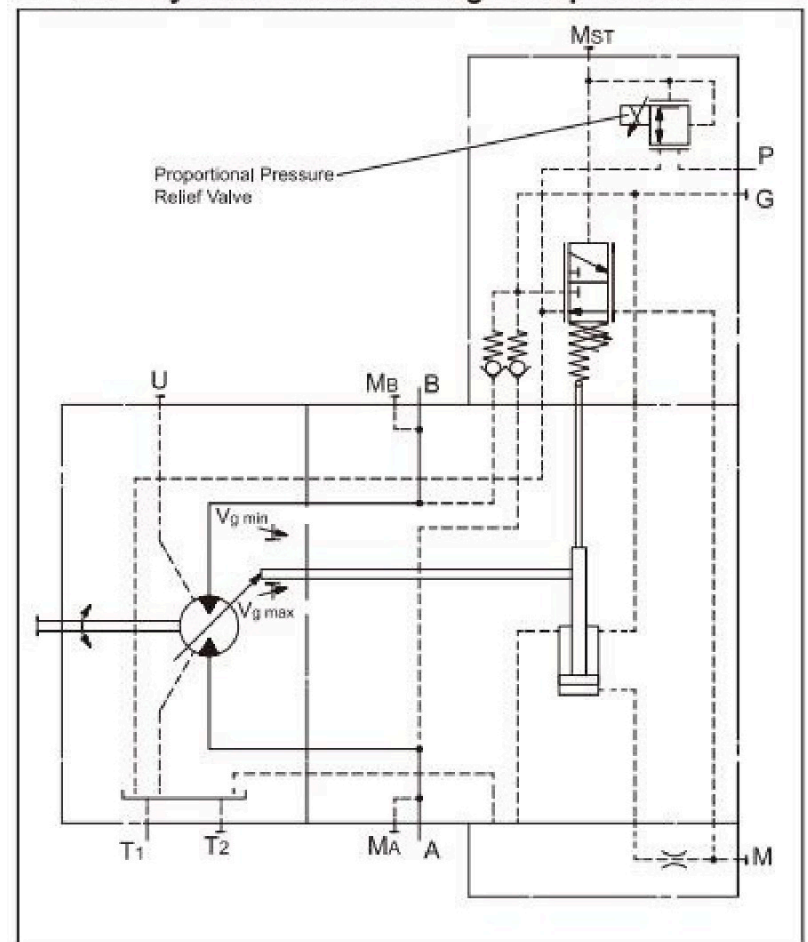



➤ **EP.D Electric Control, Fixed Setting**

Pressure control overrides EP functions. If the load torque or a reduction in motor swivel angle causes the system pressure to rise and reach the set point of the pressure control, the motor will swivel towards a larger angle. The increase in displacement and reduction in pressure cause the control deviation to decrease. By increasing the displacement, the motor develops more torque at constant pressure.
Setting range of pressure control valve: 8-40 MPa

EP.D Hydraulic control circuit diagram-displacement 28-215

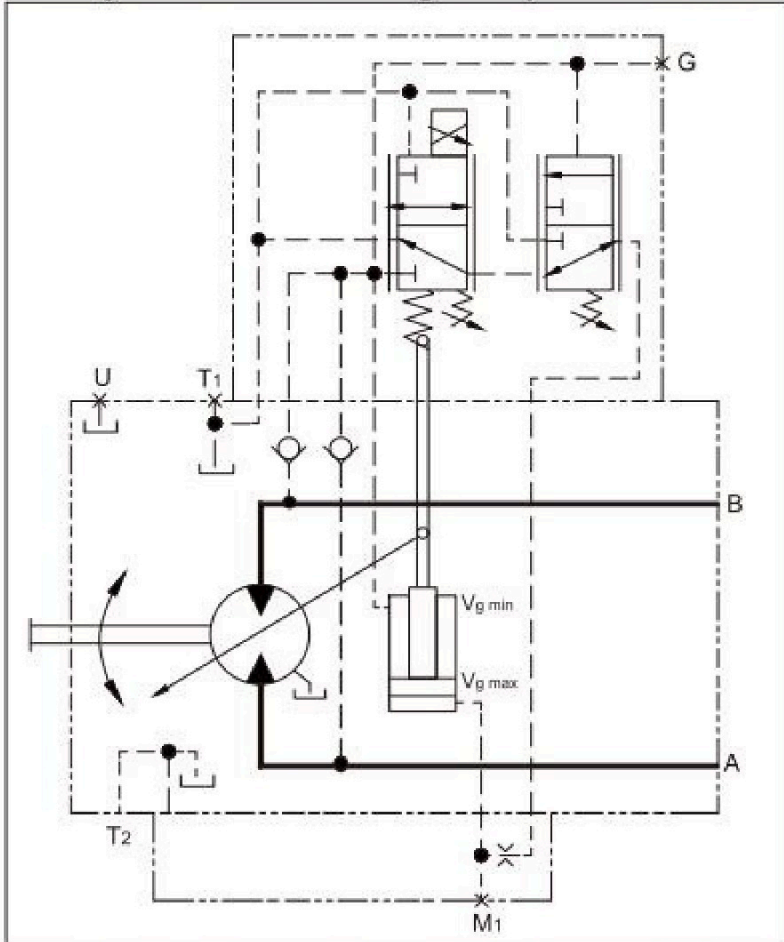

EP.D Hydraulic control circuit diagram-displacement 250

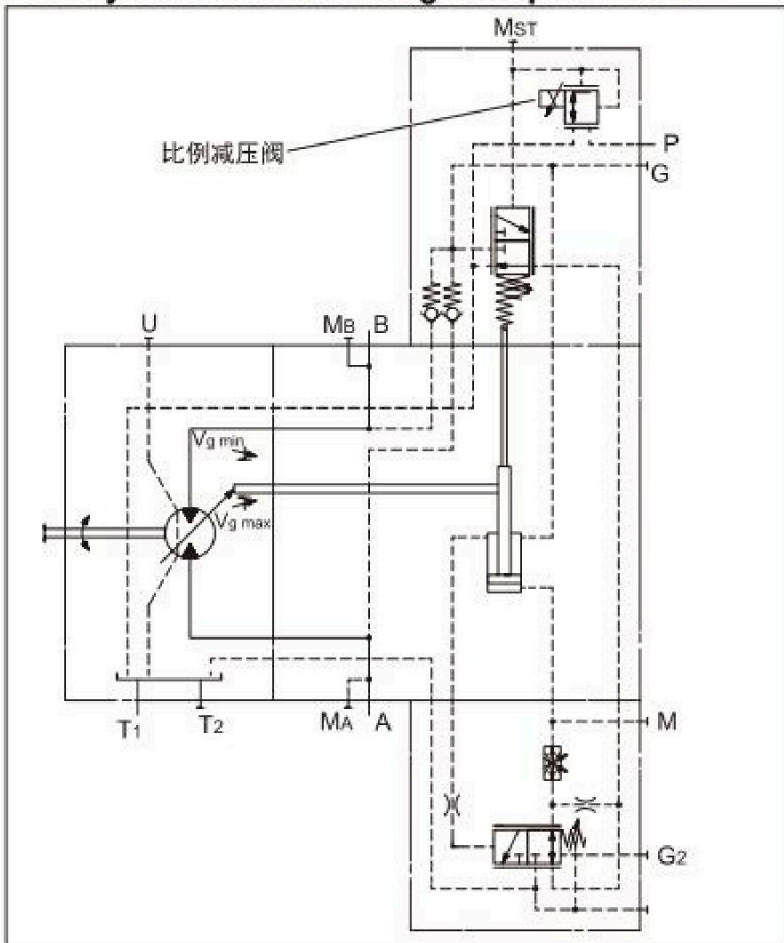

➤ **EP.E Electric Control, Two-point Hydraulic Override Control**

The pressure control setting may be overridden by applying an external pilot pressure at port G2, realizing a 2nd pressure setting.

Pilot pressure required at port G2: $P_{st}=2-5\text{MPa}$

Please specify the 2nd pressure setting in plain text when ordering.

EP.E Hydraulic control circuit diagram-displacement 28-215

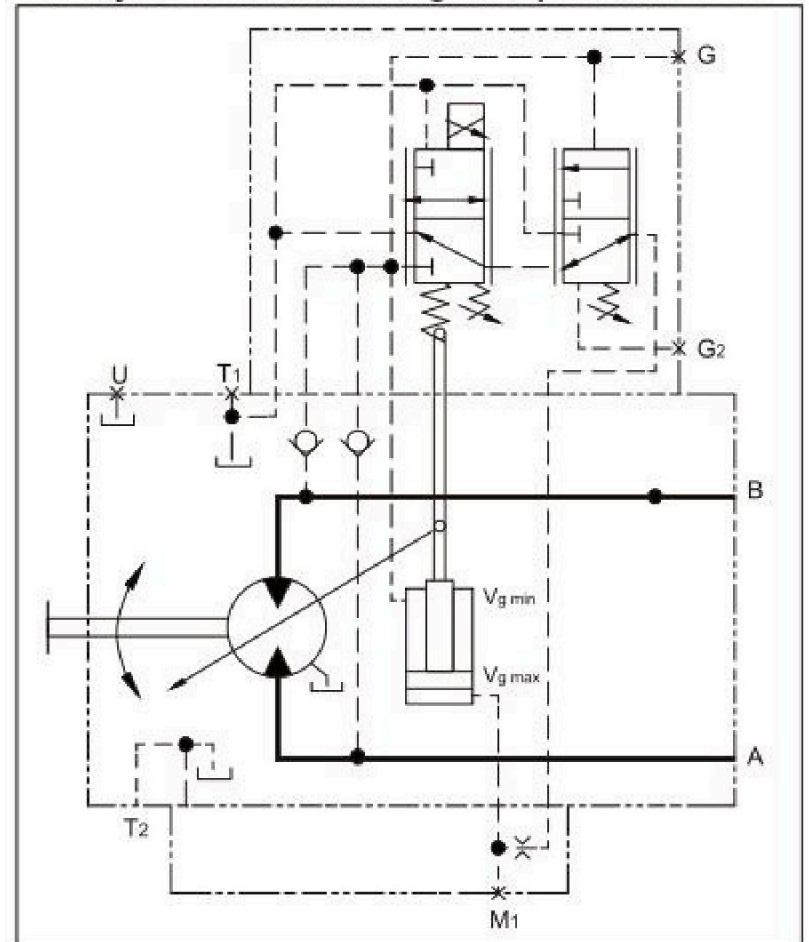



CONTROL DEVICE-EZ ELECTRIC CONTROL WITH Switching Solenoid

The electric control with switching solenoid allows the displacement to reach $V_{g \max}$ or $V_{g \min}$ by switching on or off a switching solenoid or an on/off valve.

Note:

- For stable control, a working pressure of at least 3 MPa is required at port A(B). If control is made at a working pressure < 3 MPa, an auxiliary pressure of at least 3 MPa must be applied at port G using an external check valve. Lower pressures may be needed in certain cases.

Technical data, EZ1/EZ2 solenoid with Ø37

28/107/115/160/170/200/215	EZ1	EZ2
Voltage	12V (± 20%)	24V (± 20%)
Neutral position $V_{g \max}$	De-energized	De-energized
Position $V_{g \min}$	Energized	Energized
Nominal resistance(20°C)	5.5Ω	21.7Ω
Rated output	26.2W	26.5W
Min. active current required	1.32A	0.67A
Duty cycle	100%	100%
Type of protection	IP65	

Technical data, EZ3/EZ4 solenoid with Ø45

55-215	EZ3	EZ4
Voltage	12V (± 20%)	24V (± 20%)
Neutral position $V_{g \max}$	De-energized	De-energized
Position $V_{g \min}$	Energized	Energized
Nominal resistance(20°C)	4.8Ω	19.2Ω
Rated output	30W	30W
Min. active current required	1.5A	0.75A
Duty cycle	100%	100%
Type of protection	IP65	

Technical data, control valve

250	EZ1	EZ2
Voltage	12V (± 20%)	24V (± 20%)
Neutral position $V_{g \max}$	De-energized	De-energized
Position $V_{g \min}$	Energized	Energized
Nominal resistance(20°C)	6Ω	23Ω
Rated output	26W	26W
Min. active current required	2A	1.04A
Duty cycle	100%	100%
Type of protection	IP65	

EZ1/EZ2 Hydraulic control circuit diagram-displacement 28/107/115/160/170/200/215

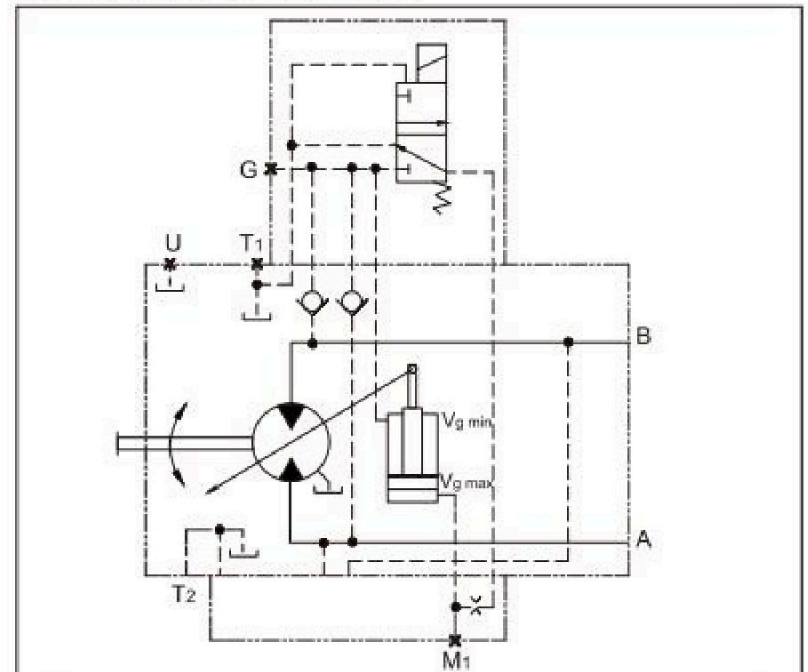

EZ1/EZ2 Hydraulic control circuit diagram-displacement 250

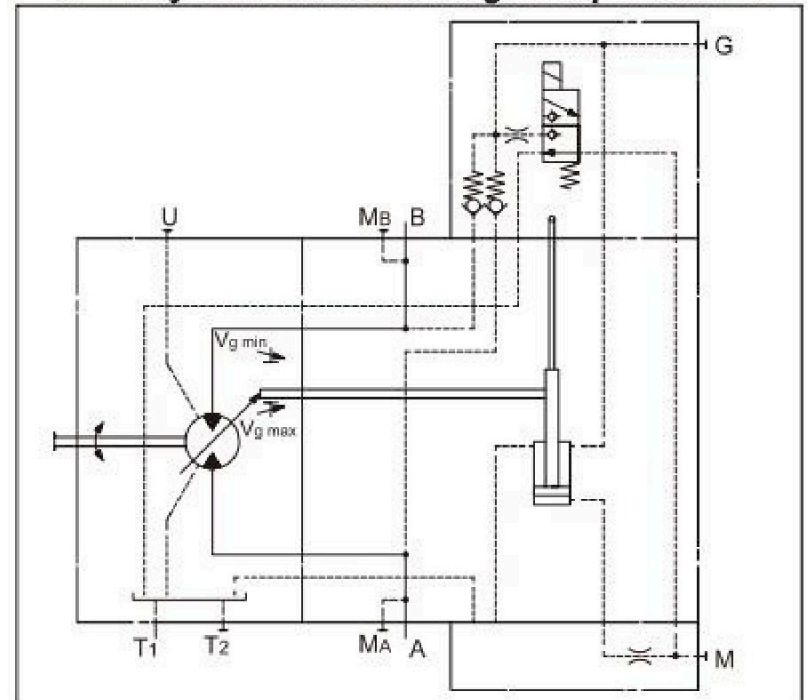

EZ3/EZ4 Hydraulic control circuit diagram-displacement 55-215

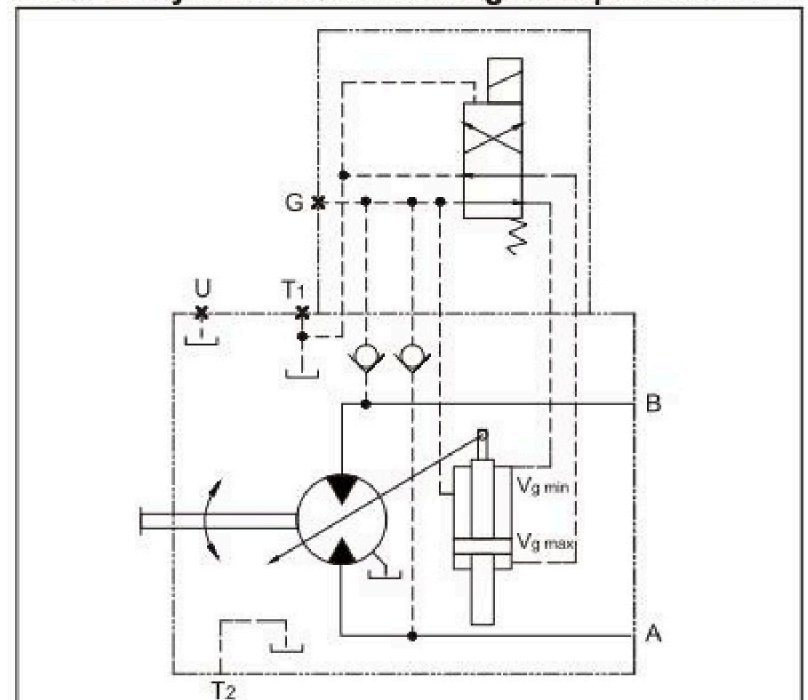



EZ.D Electric Control with Switching Solenoid, Fixed Setting

Pressure control overrides EZ functions. If the load torque or a reduction in motor swivel angle causes the system pressure to rise and reach the set point of the pressure control, the motor will swivel towards a larger angle. The increase in displacement and reduction in pressure cause the control deviation to decrease. By increasing the displacement, the motor develops more torque at constant pressure.

Setting range of pressure control valve: 8-40 MPa

EZ.D Hydraulic control circuit diagram-displacement 107-215

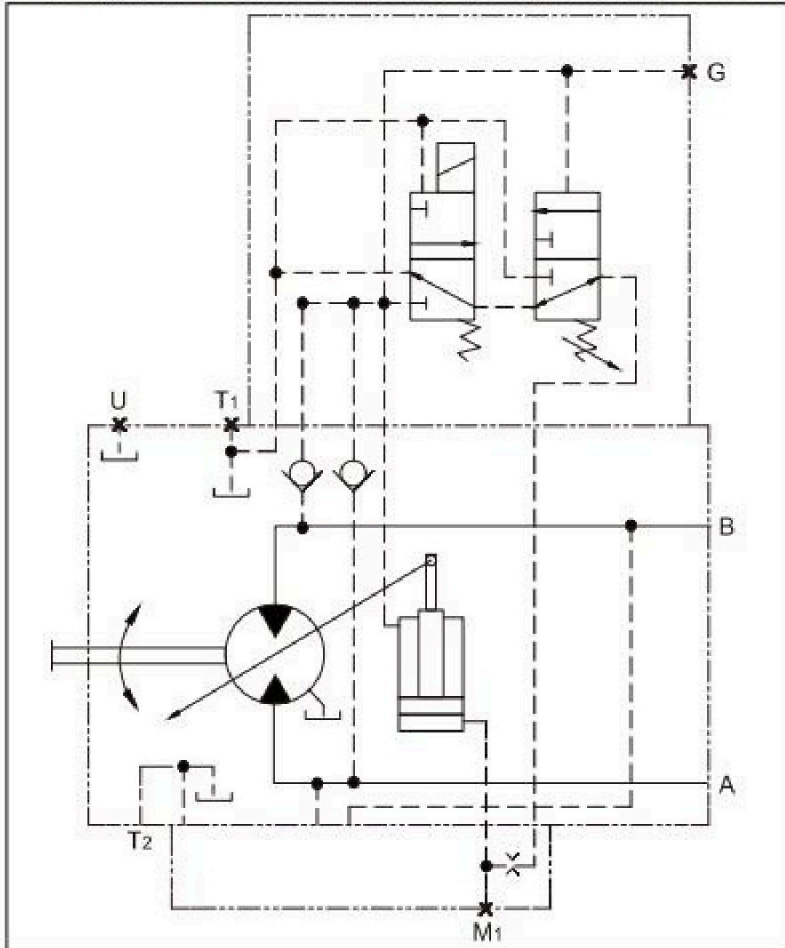



Control Device-NA high-pressure Related Automatic Control

The high-pressure related automatic control adjusts motor displacement automatically based on working pressure. The control device measures internally the working pressure at port A or B (no control line required). Once it reaches the set pressure value of the control, the motor swivels from the minimum displacement $V_{g \min}$ to the maximum displacement $V_{g \max}$ with the increasing working pressure.

Standard configuration:

- Beginning of control at $V_{g \min}$ (min. torque, max. speed)
- End of control at $V_{g \max}$ (max. torque, min. speed)

HA1 with minimum increase $\Delta p=1\text{MPa}$

A working pressure increase of $\Delta p \leq 1\text{MPa}$ results in an increase of displacement from 0 to $V_{g \max}$.

Setting range of beginning of control: 8-35MPa

Please specify the setting of beginning of control in plain text when ordering, e.g.: beginning of control = 30MPa.

HA1 Characteristic curve

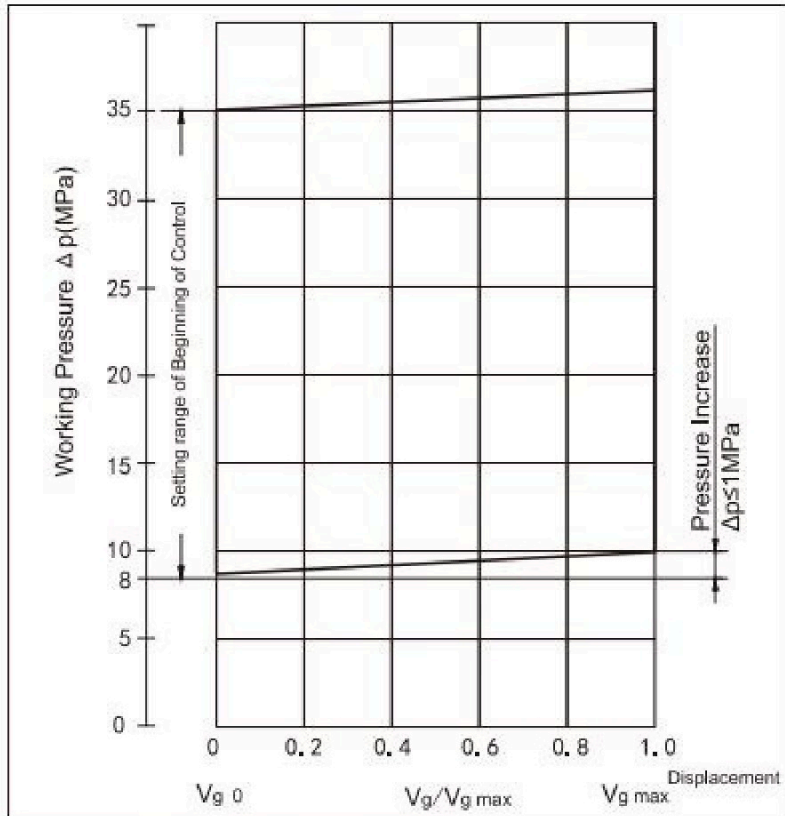

HA1 Hydraulic control circuit diagram

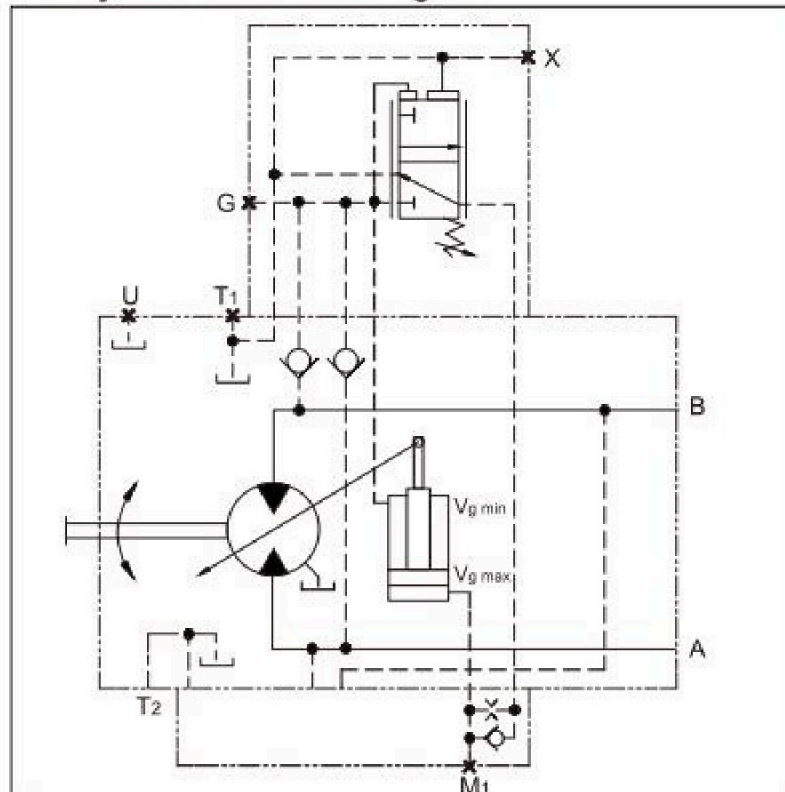

HA2 with pressure increase $\Delta p=10\text{MPa}$

A working pressure increase of $\Delta p \leq 10\text{MPa}$ results in an increase of displacement from 0 to $V_{g \max}$.

Setting range of beginning of control: 8-35MPa

Please specify the setting of beginning of control in plain text when ordering, e.g.: beginning of control = 20MPa.

HA2 Characteristic curve

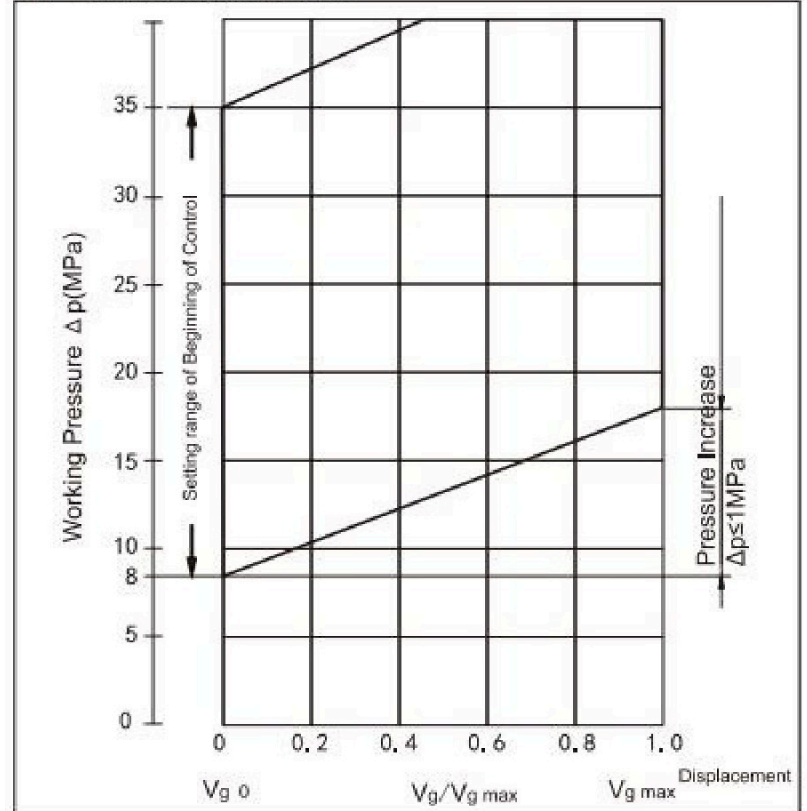

HA2 Hydraulic control circuit diagram

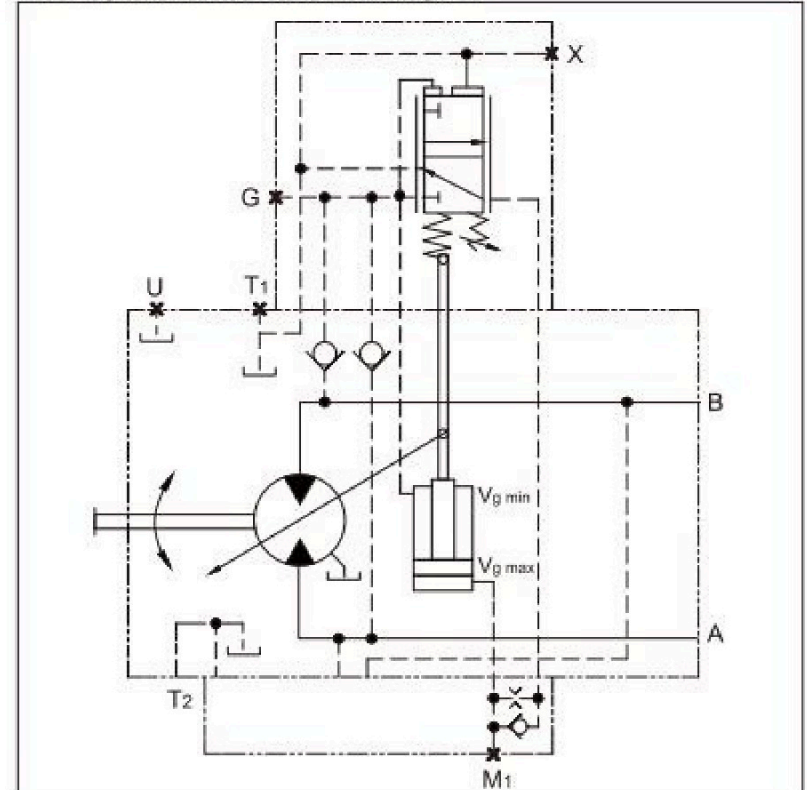



HA.T Hydraulic Override Control, Remote Control, Proportional Control

With HA.T control, the beginning of control may be changed by applying pilot pressure to port X.

For every 0.1 MPa of pilot pressure, the beginning of control is reduced by 1.7 MPa.

Example:

Setting for beginning of control	30MPa	30MPa
Pilot pressure at port X	0MPa	1MPa
Beginning of control	30MPa	13MPa

HA1.T Hydraulic control circuit diagram

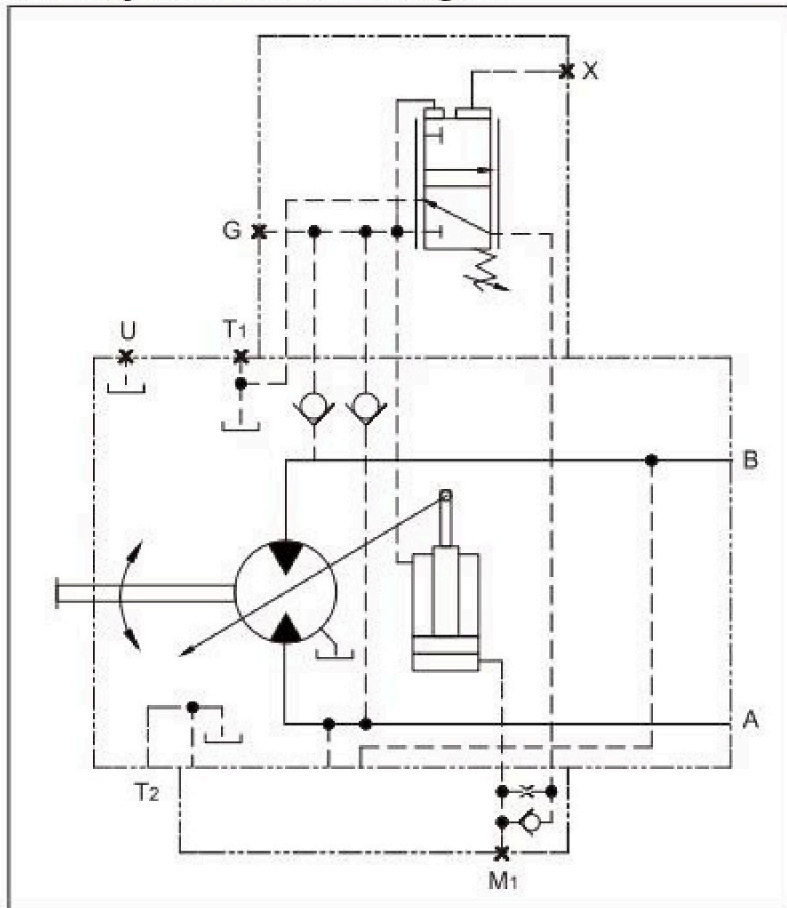

HA.U1/HA.U2 Two-point Electronic Override Control

With HA.U1 or HA.U2 control, the beginning of control may be overridden by an electric signal to a switching solenoid. When the override solenoid is energized, the variable motor swivels to the maximum swivel angle without stopping at the neutral position.

The beginning of control may be adjusted between 8-30 MPa (please specify in plain text when ordering).

Technical data, solenoid b with Ø45

	U1	U2
Voltage	12V (±20%)	24V (±20%)
No override control	De-energized	De-energized
Position $V_g \text{ min}$	Energized	Energized
Nominal resistance(20°C)	4.8Ω	19.2Ω
Rated output	30W	30W
Min. active current required	1.5A	0.75A
Duty cycle	100%	100%
Type of protection	IP65	

HA1U1/HA1U2 Hydraulic control circuit diagram

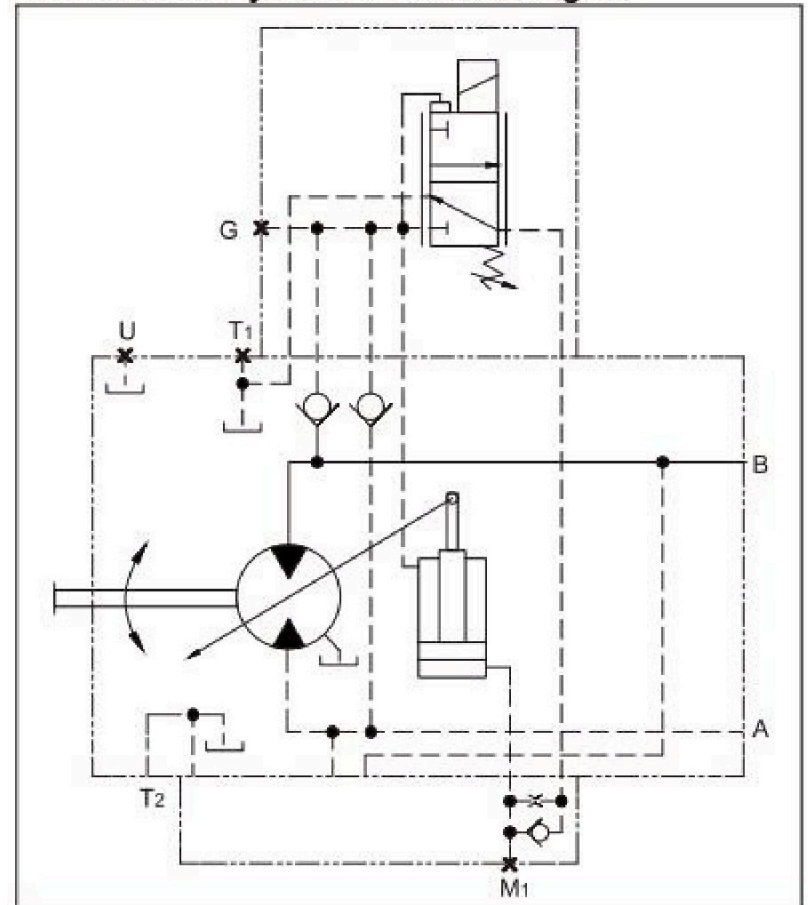



Installation Dimensions

Detail Z

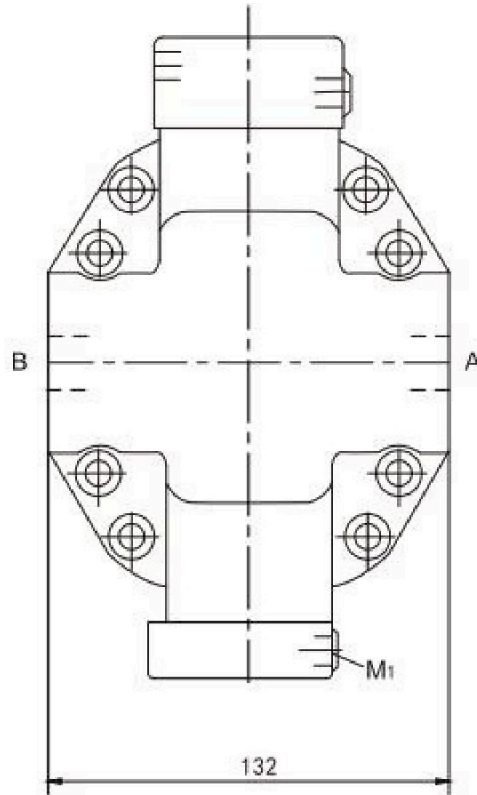

SAE flange ports A/B at side, opposite(02)

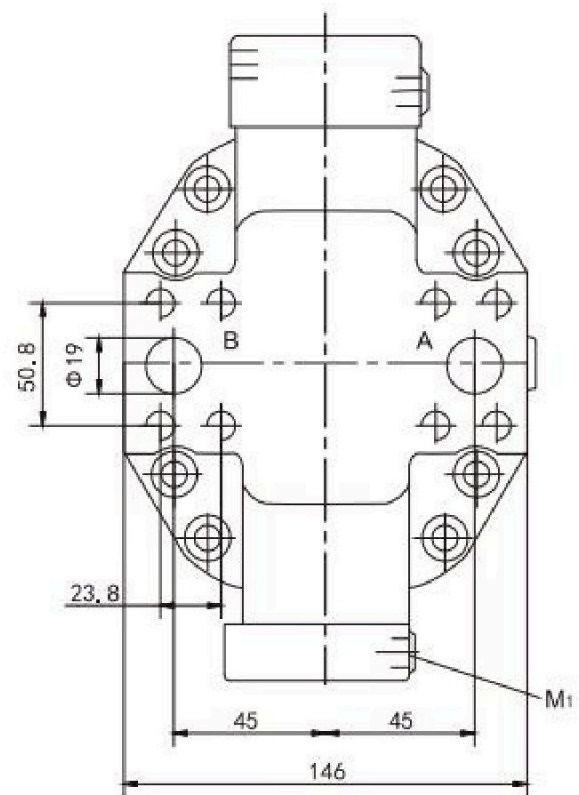

SAE flange ports A/B at rear, opposite(01)

Drive shaft

Splined shaft A DIN 5480
W30x2x30x14x9g

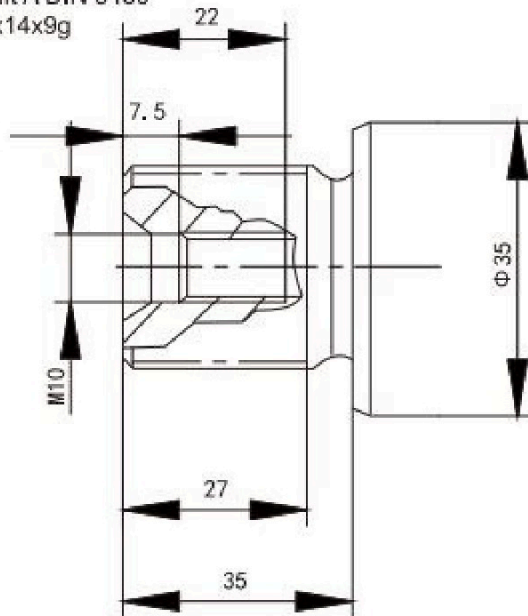

Splined shaft Z DIN 5480
W25x1.25x30x18x9g

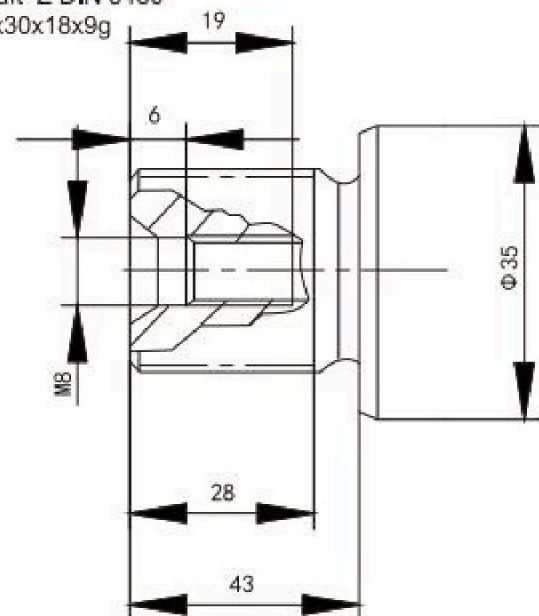

Working ports (Detail Y)

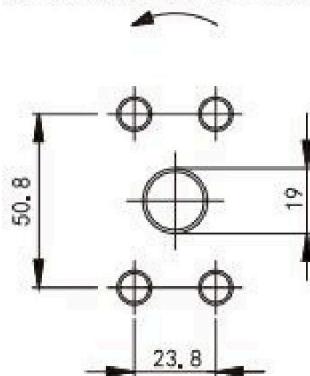

Ports

A/B	Working port	3/4 in
	Fastening thread A/B	M10, 17deep
T ₁	Case drain port	M18x1.5, 12deep
T ₂	Case drain port	M18x1.5, 12deep
U	Flushing port (plugged)	M16x1.5, 12deep
M ₁	Control pressure measurement	M14x1.5, 12deep
G	Synchronous control of multiple elements and remote control of pressure	M14x1.5, 12deep



Installation Dimensions

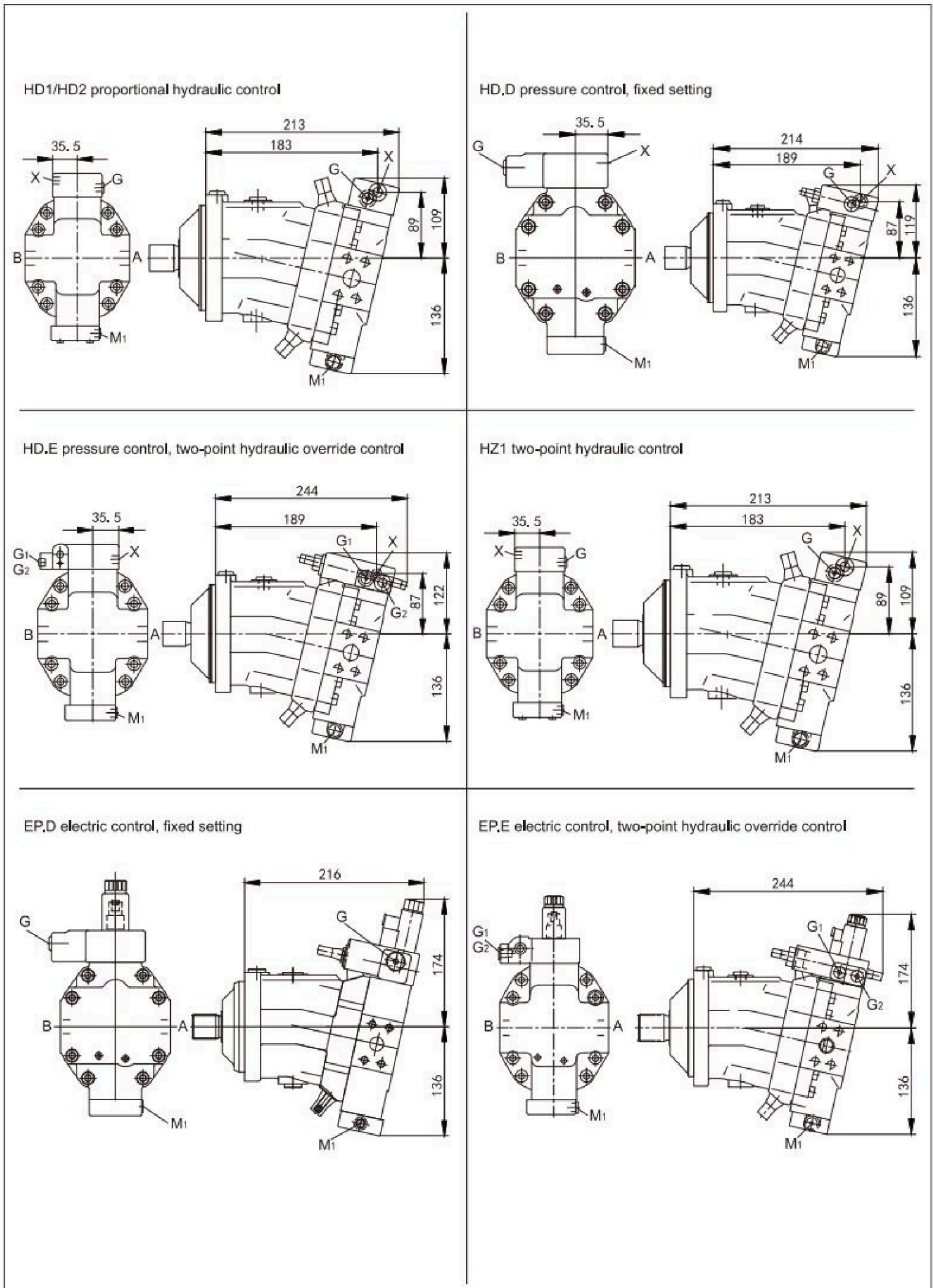



Installation Dimensions

EZ1/EZ2 electric control, with switching solenoid

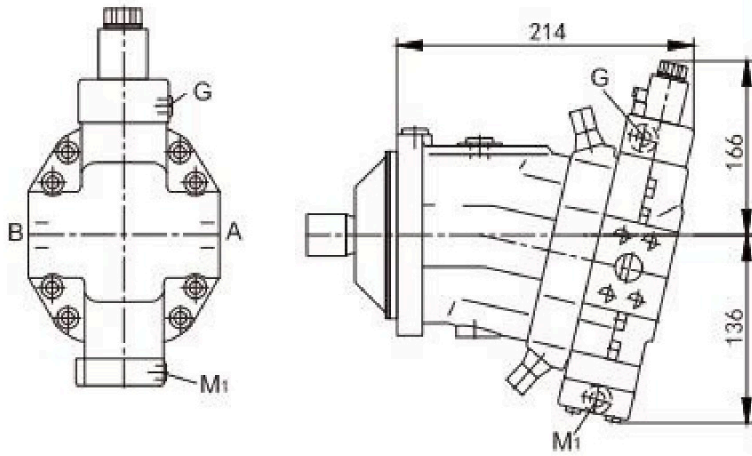

HA1/HA2, HA1T/HA2T automatic control
High-pressure related, with hydraulic override control,
remote control and proportional control

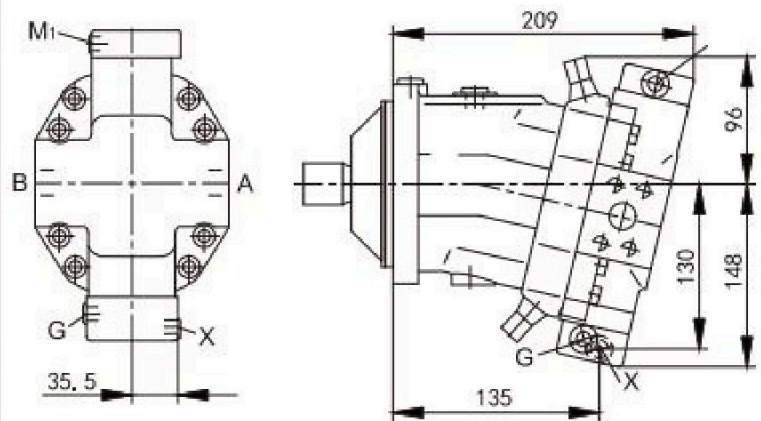

HA1U1/HA2U2 automatic control
High-pressure related, with two-point electronic override control

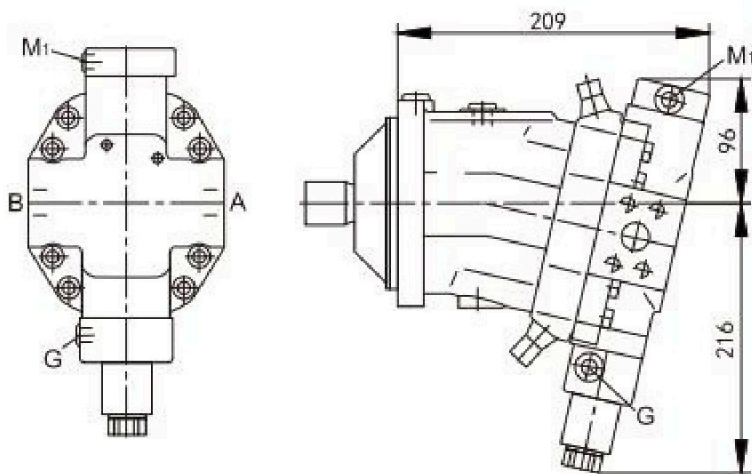



Installation Dimensions

Detail Z

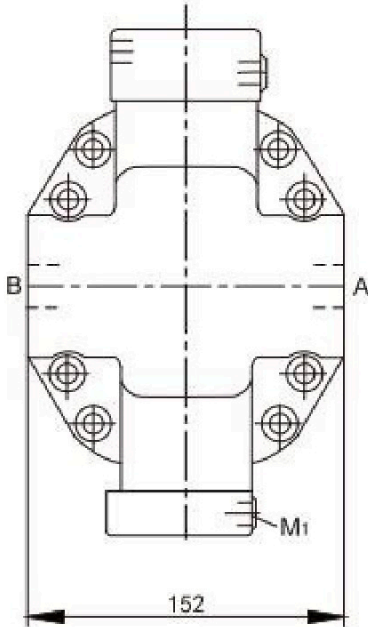

SAE flange ports A/B at side, opposite(02)

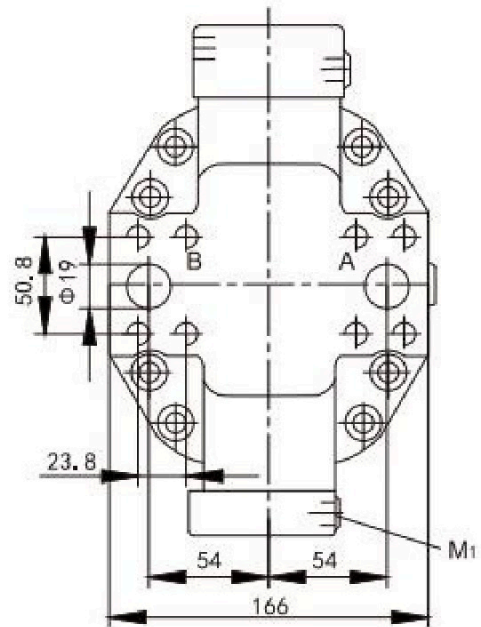

SAE flange ports A/B at rear, opposite(01)

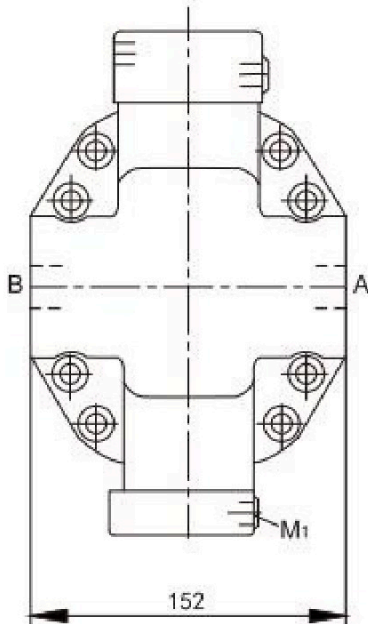

SAE flange ports A/B at side, opposite (02),
only for HZ3/EZ3/EZ4

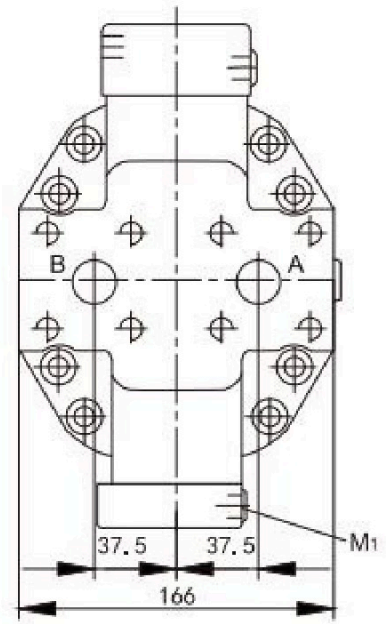

SAE flange ports A/B at rear, opposite (01),
only for HZ3/EZ3/EZ4

Drive shaft

Splined shaft A DIN 5480
W35x2x30x16x9g

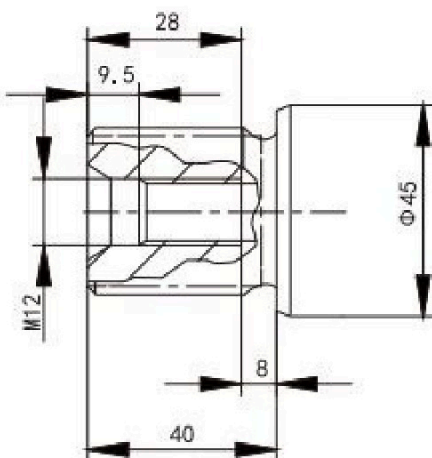

Splined shaft Z DIN 5480
W30x2x30x14x9g

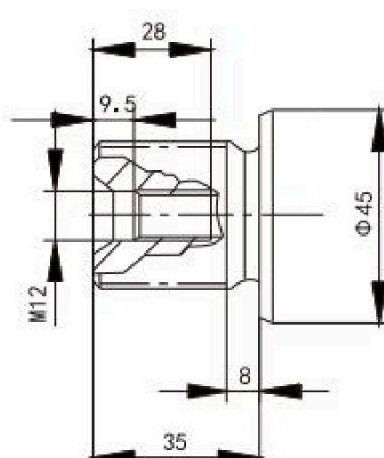

Ports

A/B	Working port (high pressure series)	3/4 in
	Fastening thread A/B	M10, 17deep
T1	Case drain port	M18x1.5, 12deep
T2	Case drain port	M18x1.5, 12deep
U	Flushing port (plugged)	M18x1.5, 12deep
M1	Control pressure measurement	M14x1.5, 12deep
G	Synchronous control of multiple elements and remote control of pressure	M14x1.5, 12deep



Installation Dimensions

EZ3 two-point hydraulic control

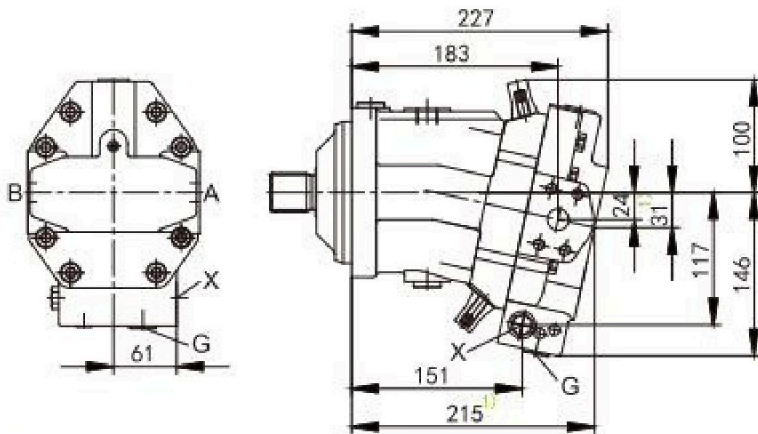

1) : Port plate 1 - SAE flange ports A and B at rear

HP1/HP2 electric control, with proportional solenoid

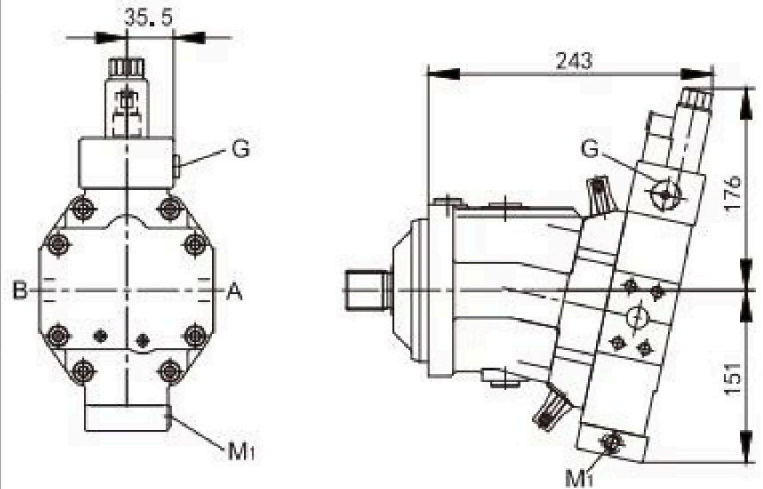

HD.D pressure control, fixed setting

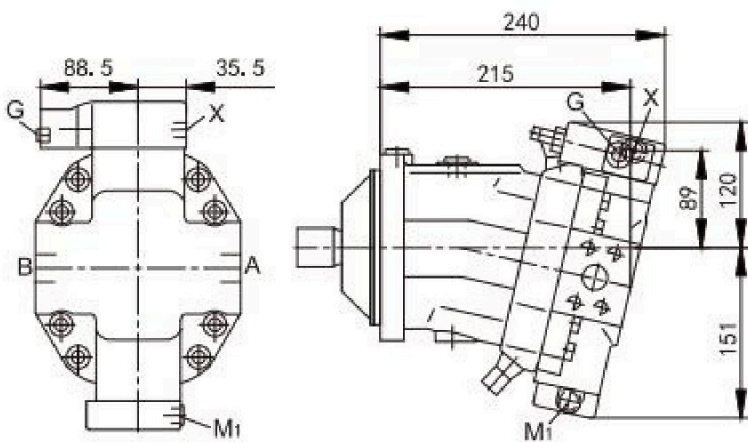

HD.E pressure control, two-point hydraulic override control

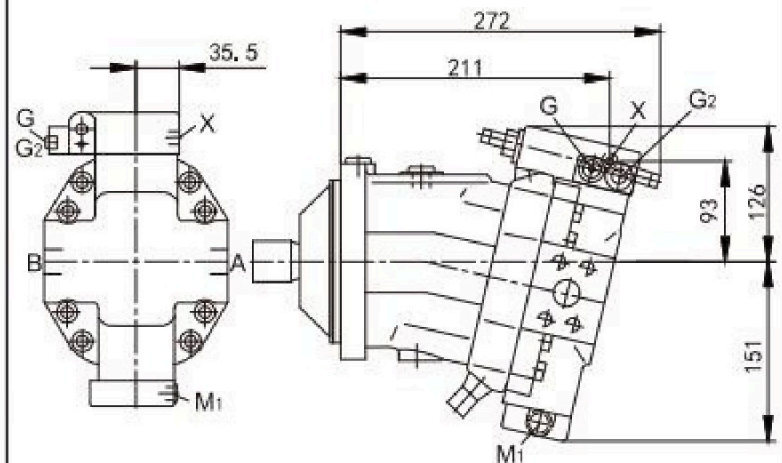

EP.D electric control, fixed setting

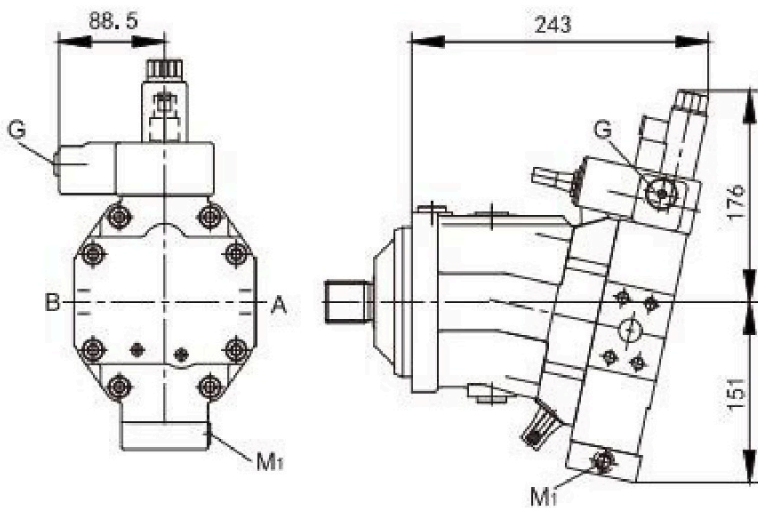

EP.E electric control, two-point hydraulic override control

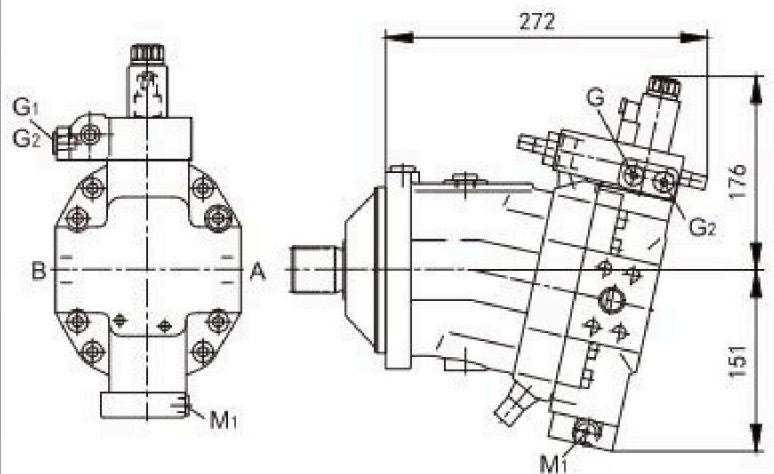



Installation Dimensions

EZ3/EZ4 electric control, with switching solenoid

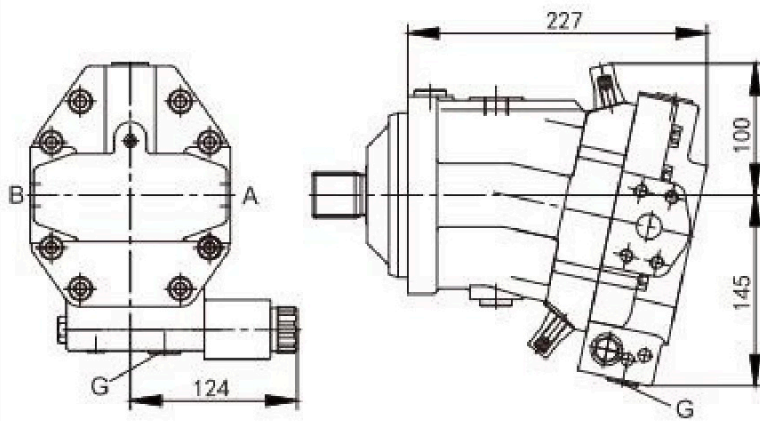

HA1/HA2, HA1T/HA2T automatic control
High-pressure related, with hydraulic override control,
remote control and proportional control

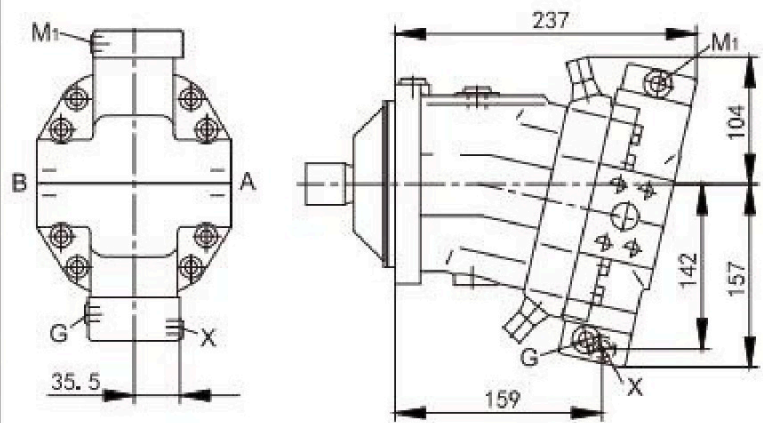

HA1U1/HA2U2 automatic control
High-pressure related, with two-point electronic override control

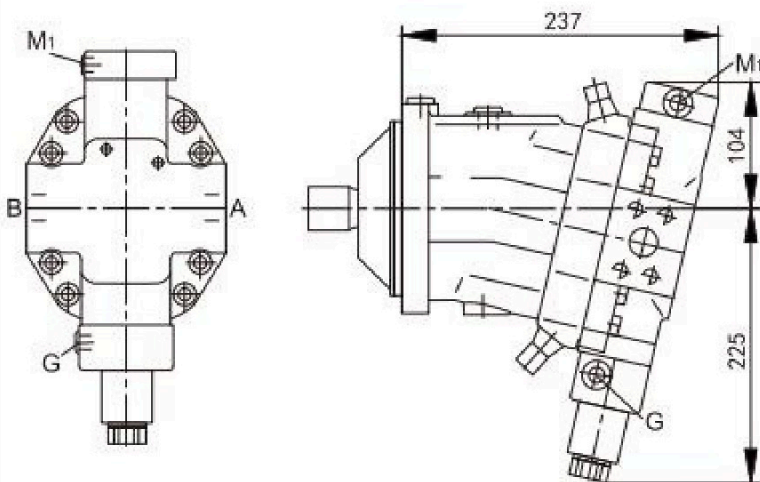



Installation Dimensions

Size 80

HD1/HD2 proportional hydraulic control
SAE flange ports A/B at side, opposite(02)

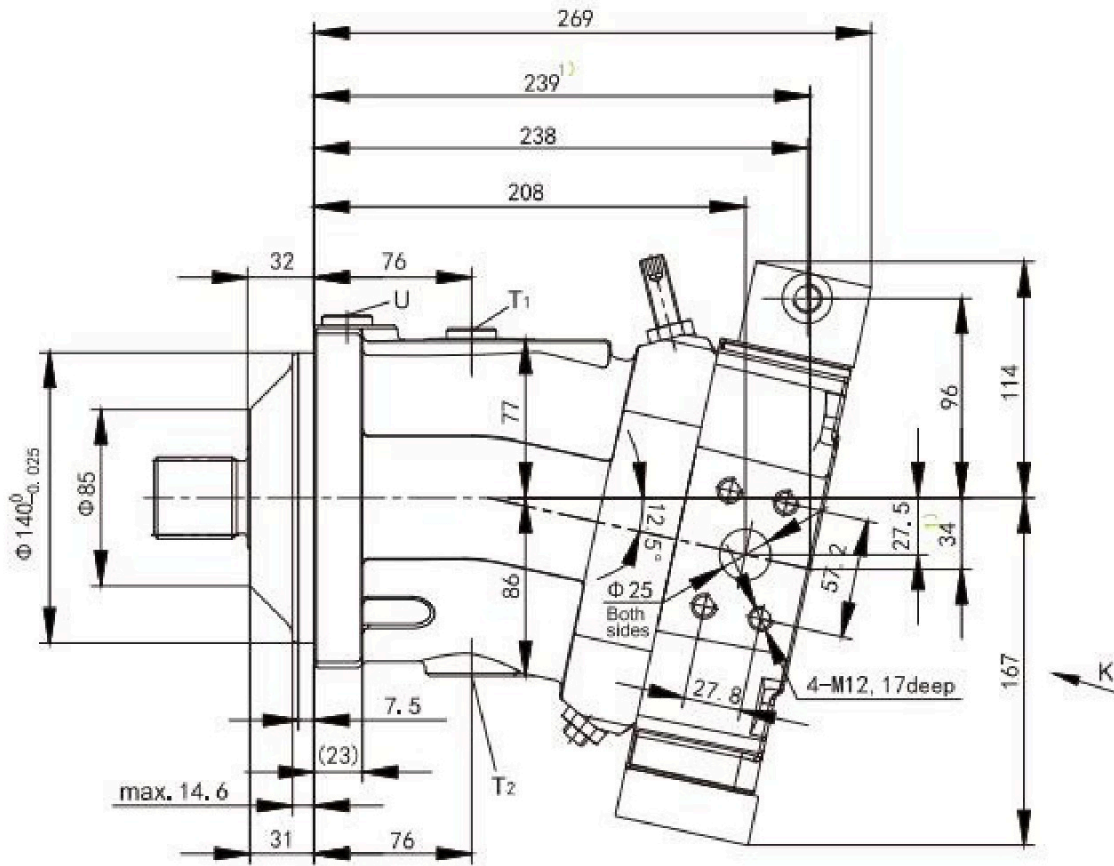

1): Working ports A/B at rear (port plate 01)

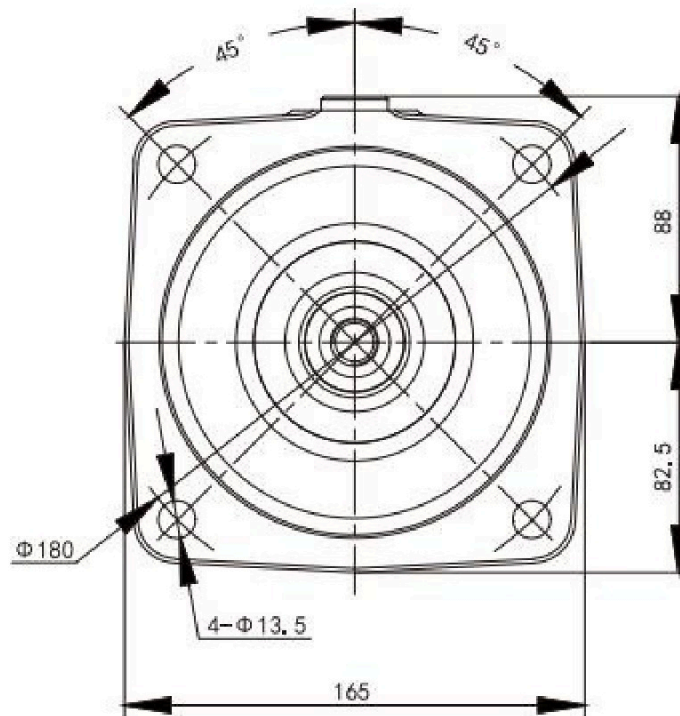



Installation Dimensions

Detail Z

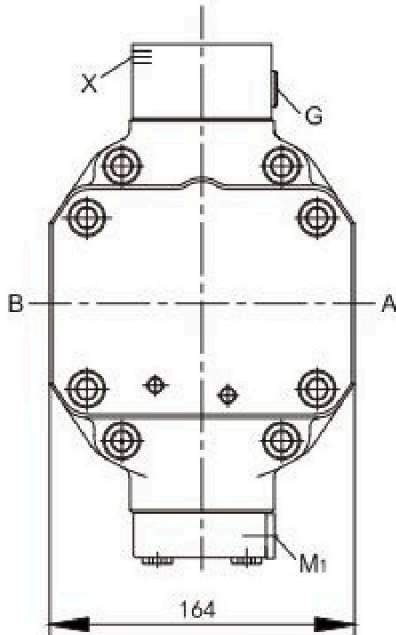

SAE flange ports A/B at side, opposite(02)

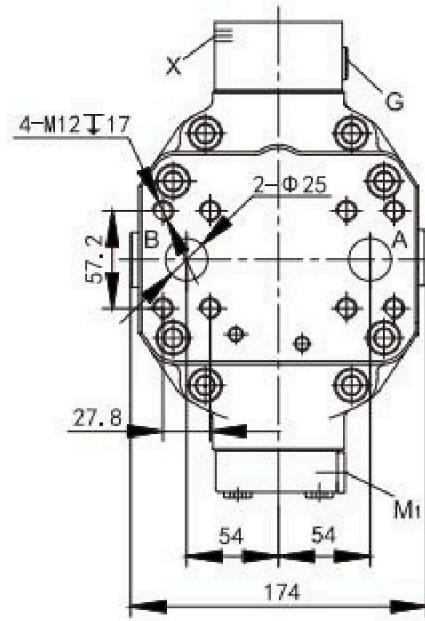

SAE flange ports A/B at rear, opposite(01)

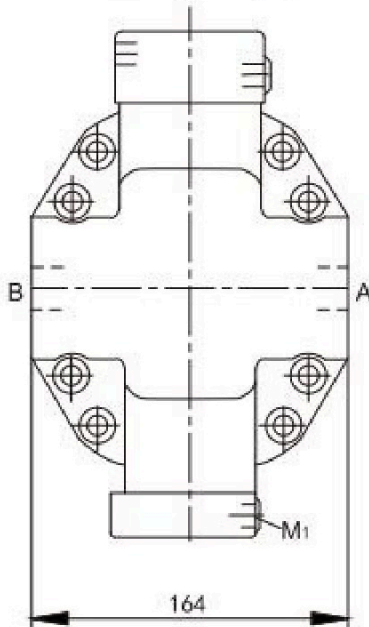

SAE flange ports A/B at side, opposite (02), only for HZ3/EZ3/EZ4

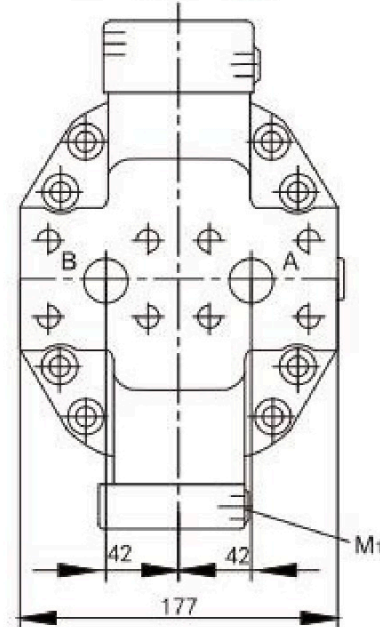

SAE flange ports A/B at rear, opposite (01), only for HZ3/EZ3/EZ4

Drive shaft

Splined shaft A DIN 5480
W40x2x30x18x9g

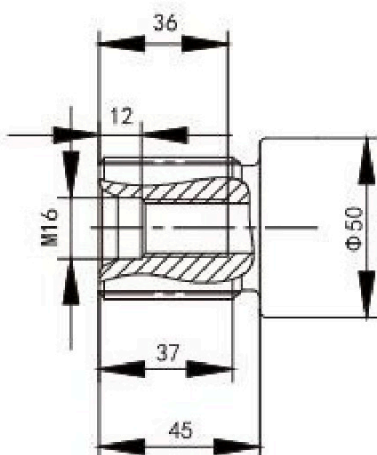

Splined shaft Z DIN 5480
W35x2x30x16x9g

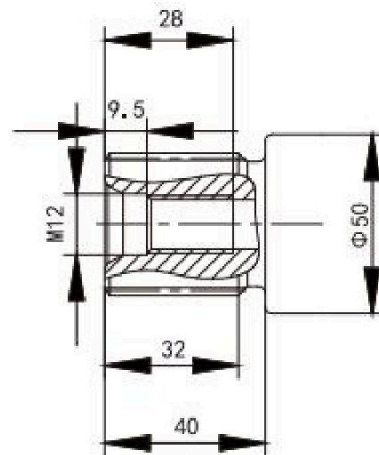

Ports

A/B	Working port (high pressure series)	1 in
	Fastening thread A/B	M12, 17deep
T ₁	Case drain port	M18x1.5, 12deep
T ₂	Case drain port	M18x1.5, 12deep
U	Flushing port (plugged)	M18x1.5, 12deep
M ₁	Control pressure measurement	M14x1.5, 12deep
G	Synchronous control of multiple elements and remote control of pressure	M14x1.5, 12deep



Installation Dimensions

EP1/EP2 electric control, with proportional solenoid

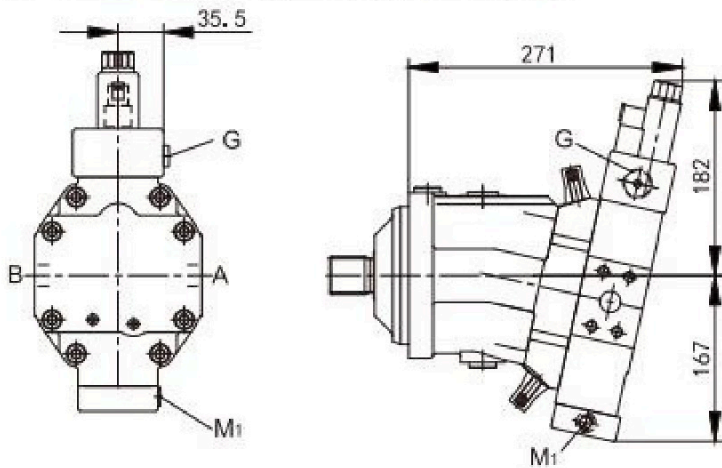

EP,D electric control, fixed setting

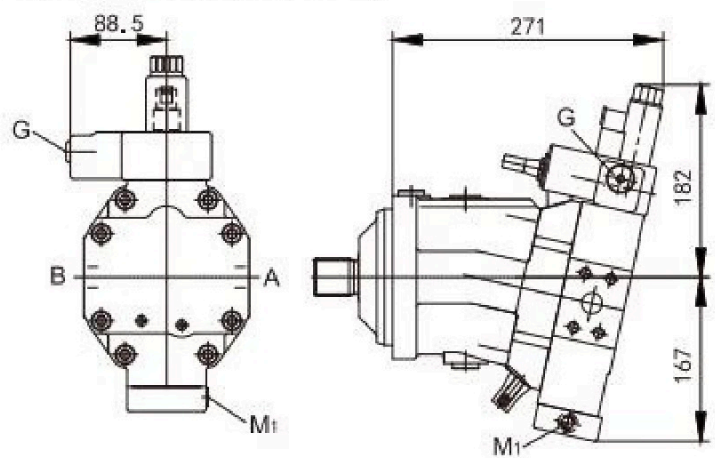

EP,E electric control, two-point hydraulic override control

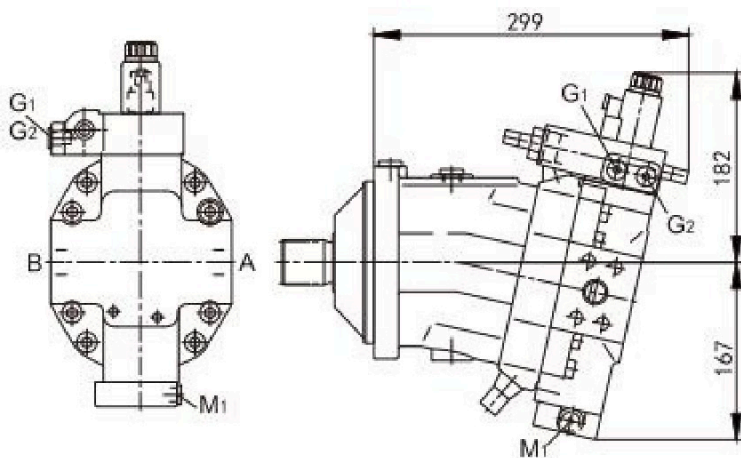

HZ3 two-point hydraulic control

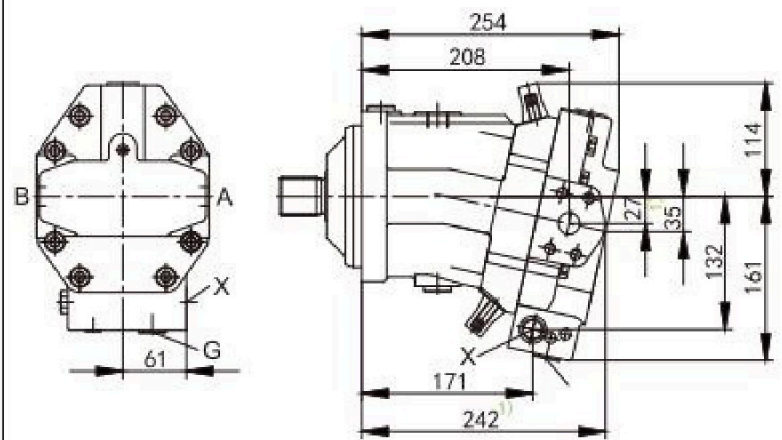

1) Port plate 1 - SAE flange ports A and B at rear

EZ3/EZ4 electric control, with switching solenoid

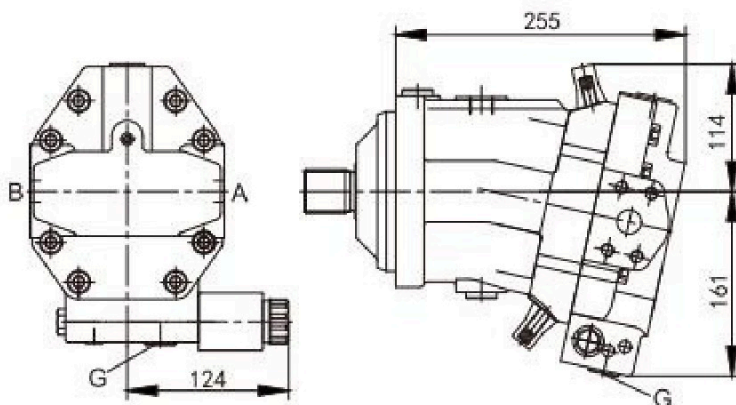

HD,D pressure control, fixed setting

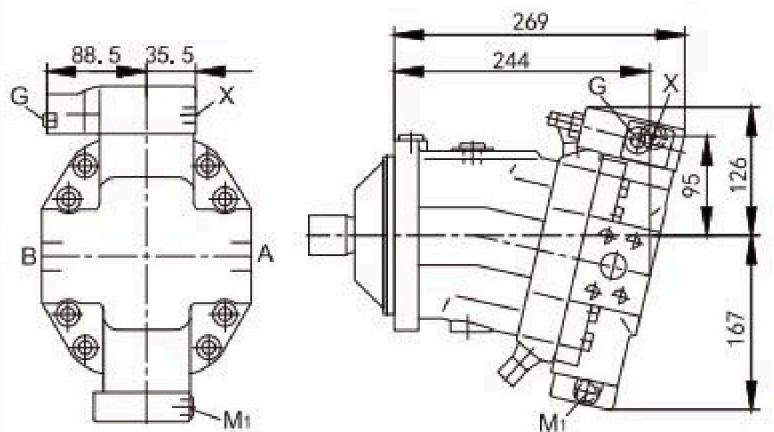



Installation Dimensions

HD,E pressure control, two-point hydraulic override control

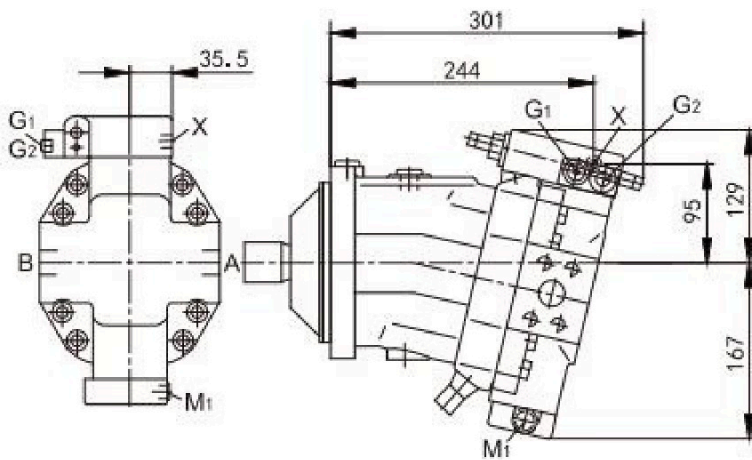

HA1/HA2,HA1T/HA2T automatic control
High-pressure related, with hydraulic override control,
remote control and proportional control

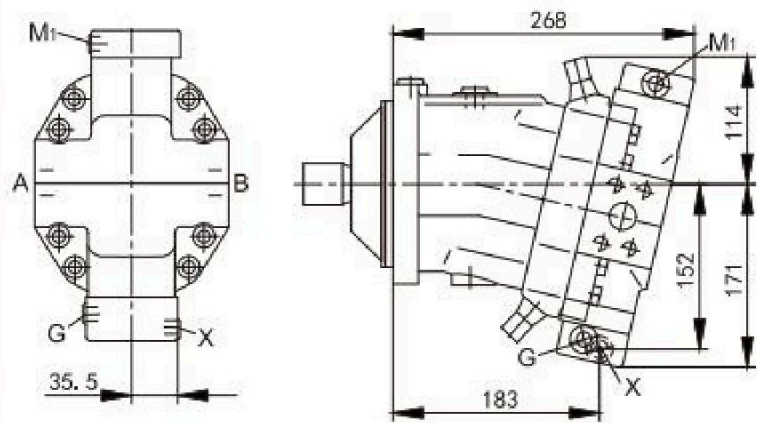

HA1U1/HA2U2 automatic control
High-pressure related, with two-point electronic override control

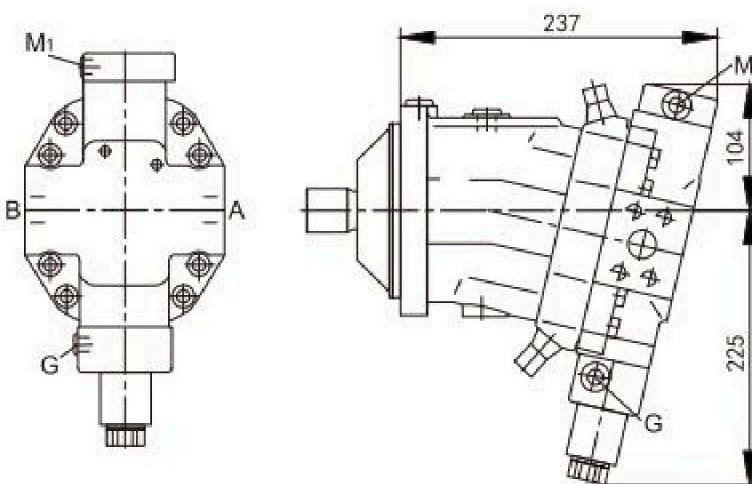



Installation Dimensions

Detail Z

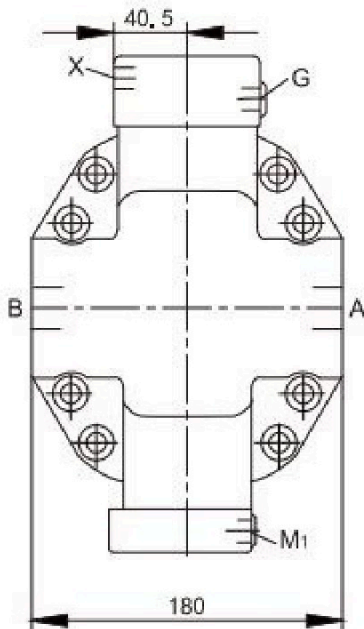

SAE flange ports A/B at side, opposite(02)

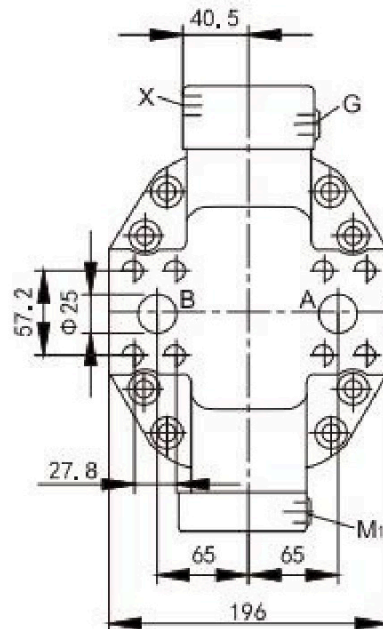

SAE flange ports A/B at rear, opposite(01)

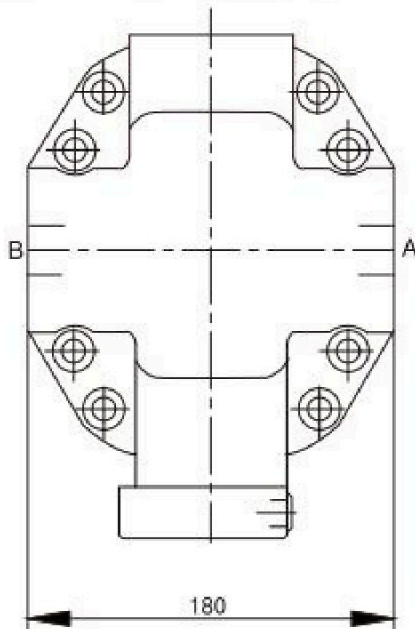

SAE flange ports A/B at side, opposite (02),
only for HZ3/EZ3/EZ4

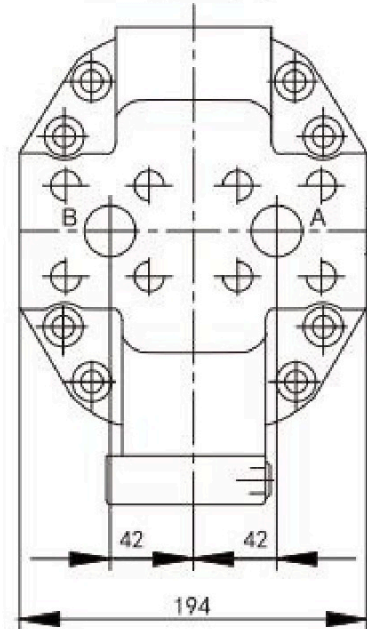

SAE flange ports A/B at rear, opposite (01),
only for HZ3/EZ3/EZ4

Drive shaft

Splined shaft A DIN 5480
W45x2x30x21x9g

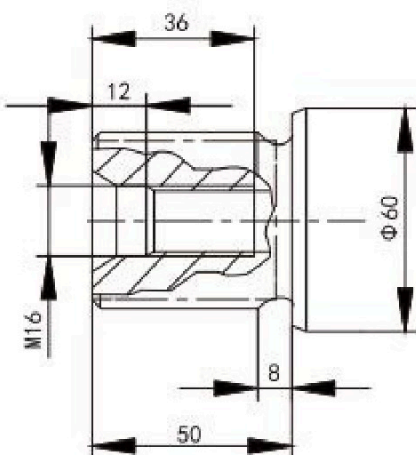

Splined shaft Z DIN 5480
W40x2x30x18x9g

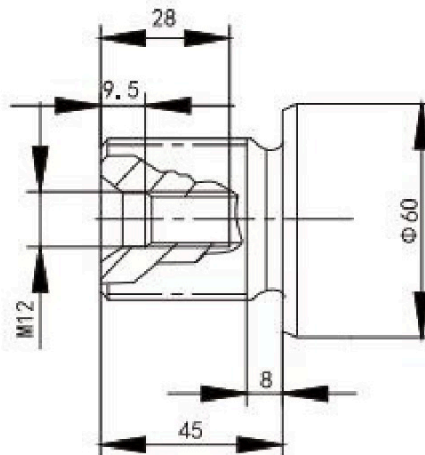

Ports

A/B	Working port (high pressure series)	1 in
	Fastening thread A/B	M12, 17deep
T1	Case drain port	M18x1.5, 12deep
T2	Case drain port	M18x1.5, 12deep
X	Pilot pressure port	M14x1.5, 12deep
U	Flushing port (plugged)	M18x1.5, 12deep
M1	Control pressure measurement	M14x1.5, 12deep
G	Synchronous control of multiple elements and remote control of pressure	M14x1.5, 12deep
G2	2nd pressure setting (plugged)	M14x1.5, 12deep



Installation Dimensions

HD.D pressure control, fixed setting

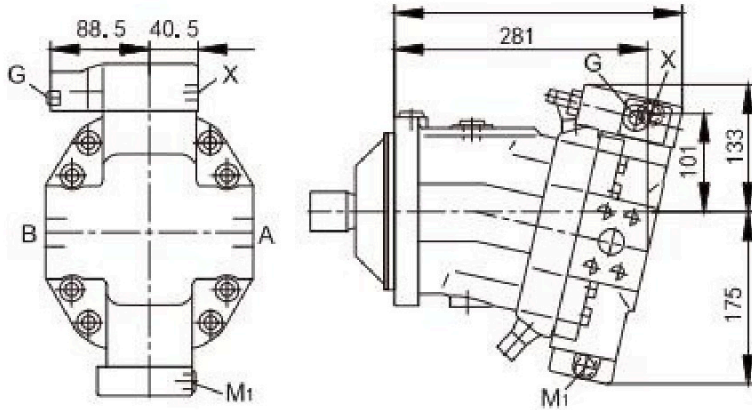

HD.E pressure control, two-point hydraulic override control

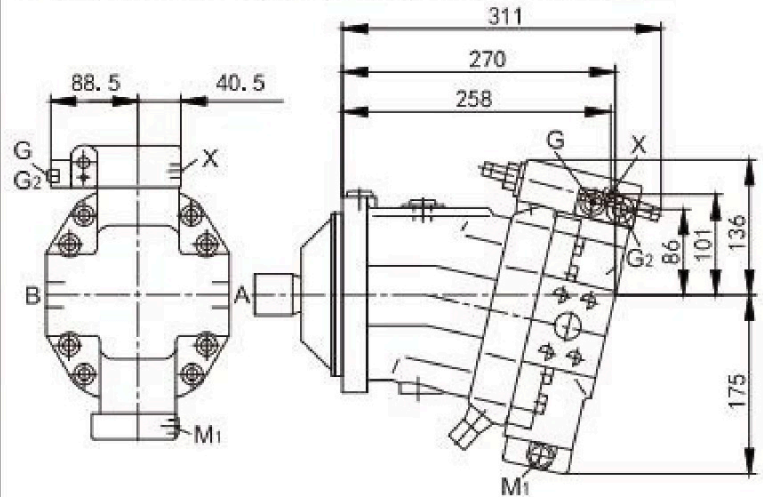

EP1/EP2 electric control, with proportional solenoid

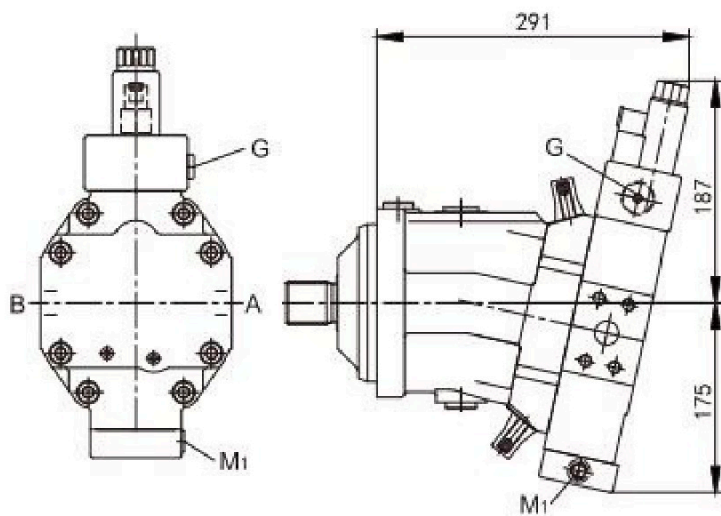

EP.D electric control, fixed setting

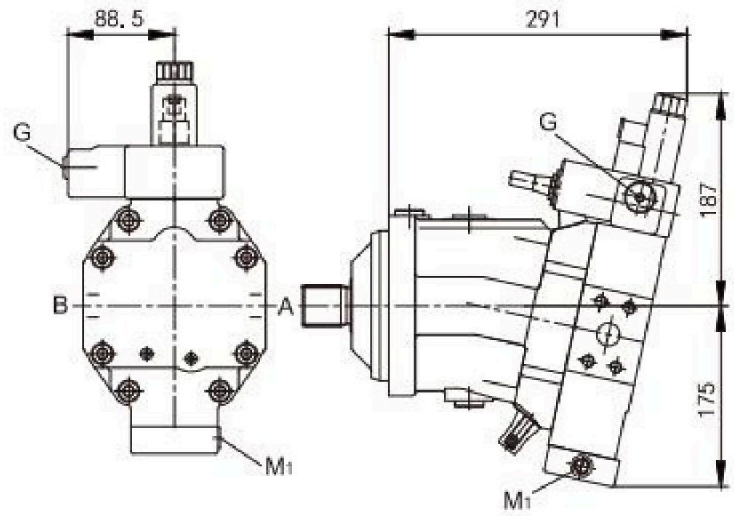

EP.E electric control, two-point hydraulic override control

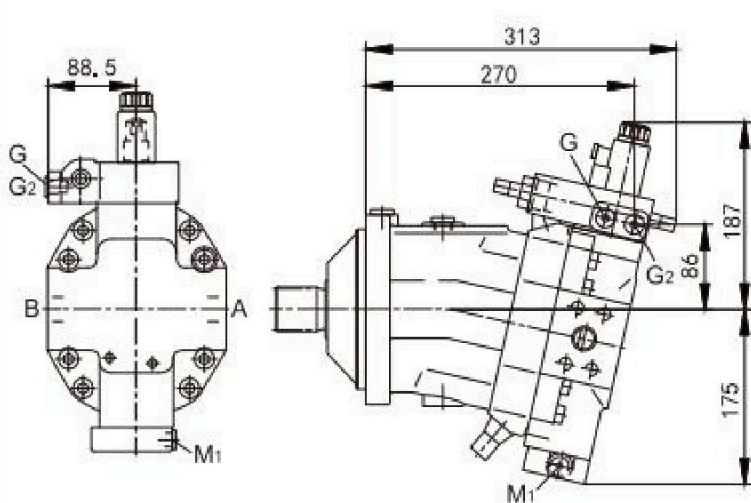

EZ.D electric control, with switching solenoid, fixed setting

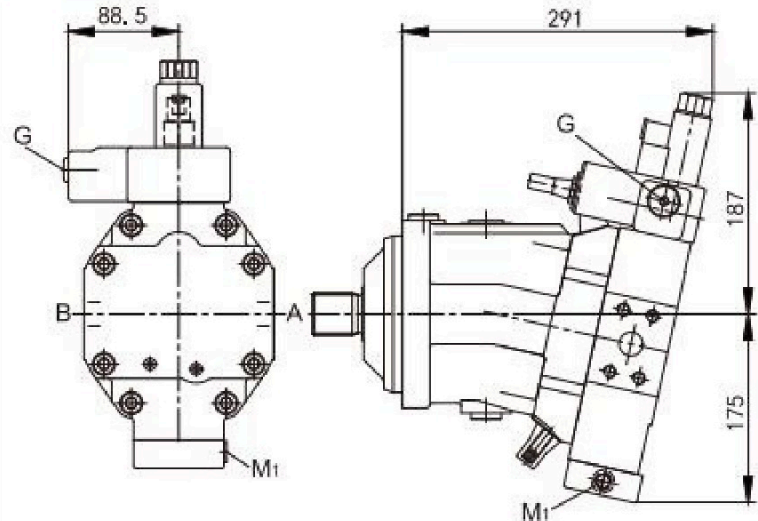



Installation Dimensions

EZ3/EZ4 electric control, with switching solenoid

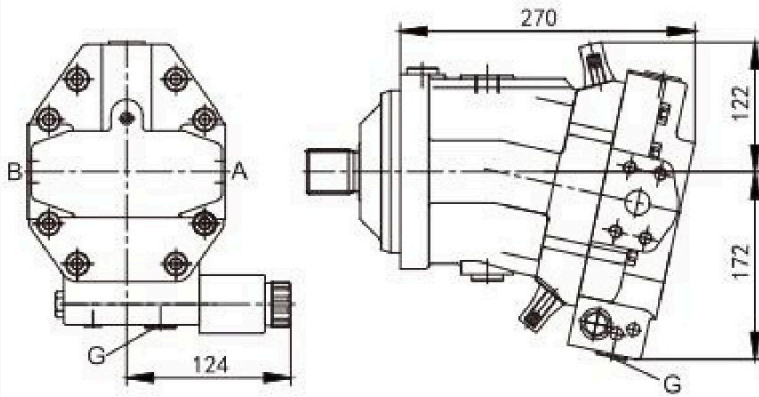

HA1/HA2, HA1T/HA2T automatic control
High-pressure related, with hydraulic override control,
remote control and proportional control

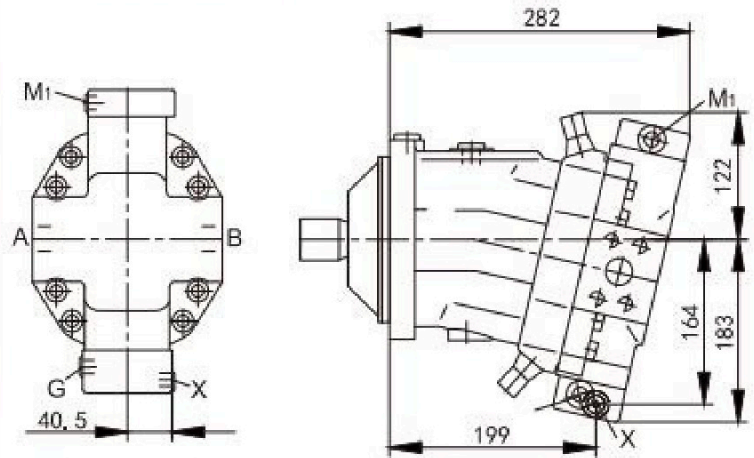

HA1/HA2 _____ X堵性
HA1T/HA2T _____ X打开

HA1U1/HA2U2 automatic control
High-pressure related, with two-point electronic override control

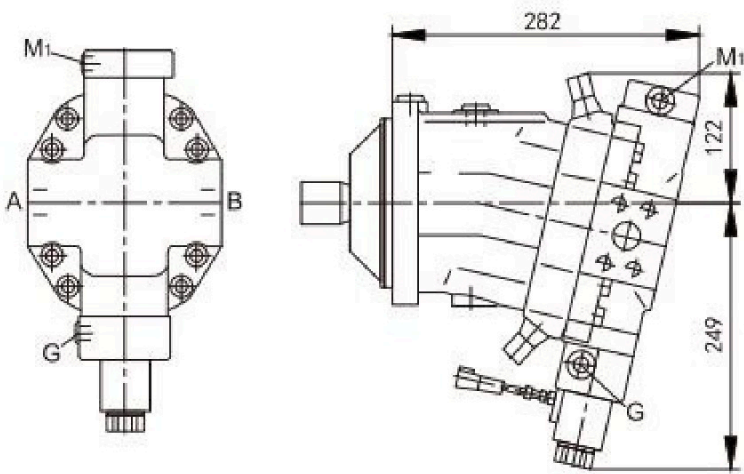



Installation Dimensions

Detail Z

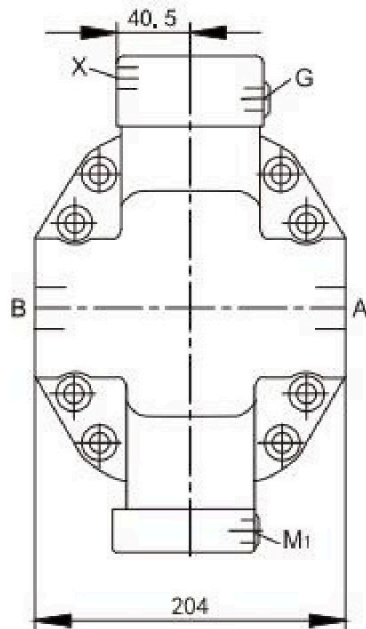

SAE flange ports A/B at side, opposite(02)

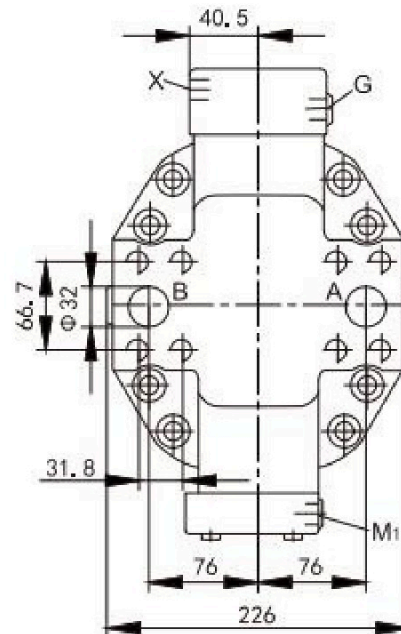

SAE flange ports A/B at rear, opposite(01)

Drive shaft

Splined shaft A DIN 5480
W50x2x30x24x9g

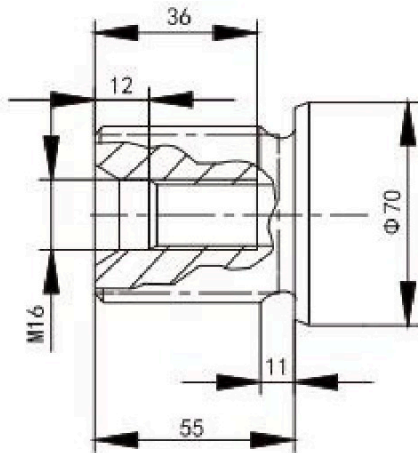

Splined shaft Z DIN 5480
W45x2x30x21x9g

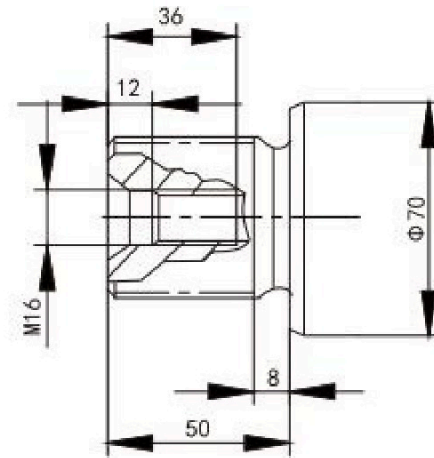

Ports

A/B	Working port (high pressure series)	1 1/4 in
	Fastening thread A/B	M14, 19deep
T1	Case drain port	M26x1.5, 16deep
T2	Case drain port	M26x1.5, 16deep
X	Pilot pressure port	M14x1.5, 12deep
U	Flushing port (plugged)	M22x1.5, 14deep
M1	Control pressure measurement	M14x1.5, 12deep
G	Synchronous control of multiple elements and remote control of pressure	M14x1.5, 12deep
G2	2nd pressure setting (plugged)	M14x1.5, 12deep



Installation Dimensions

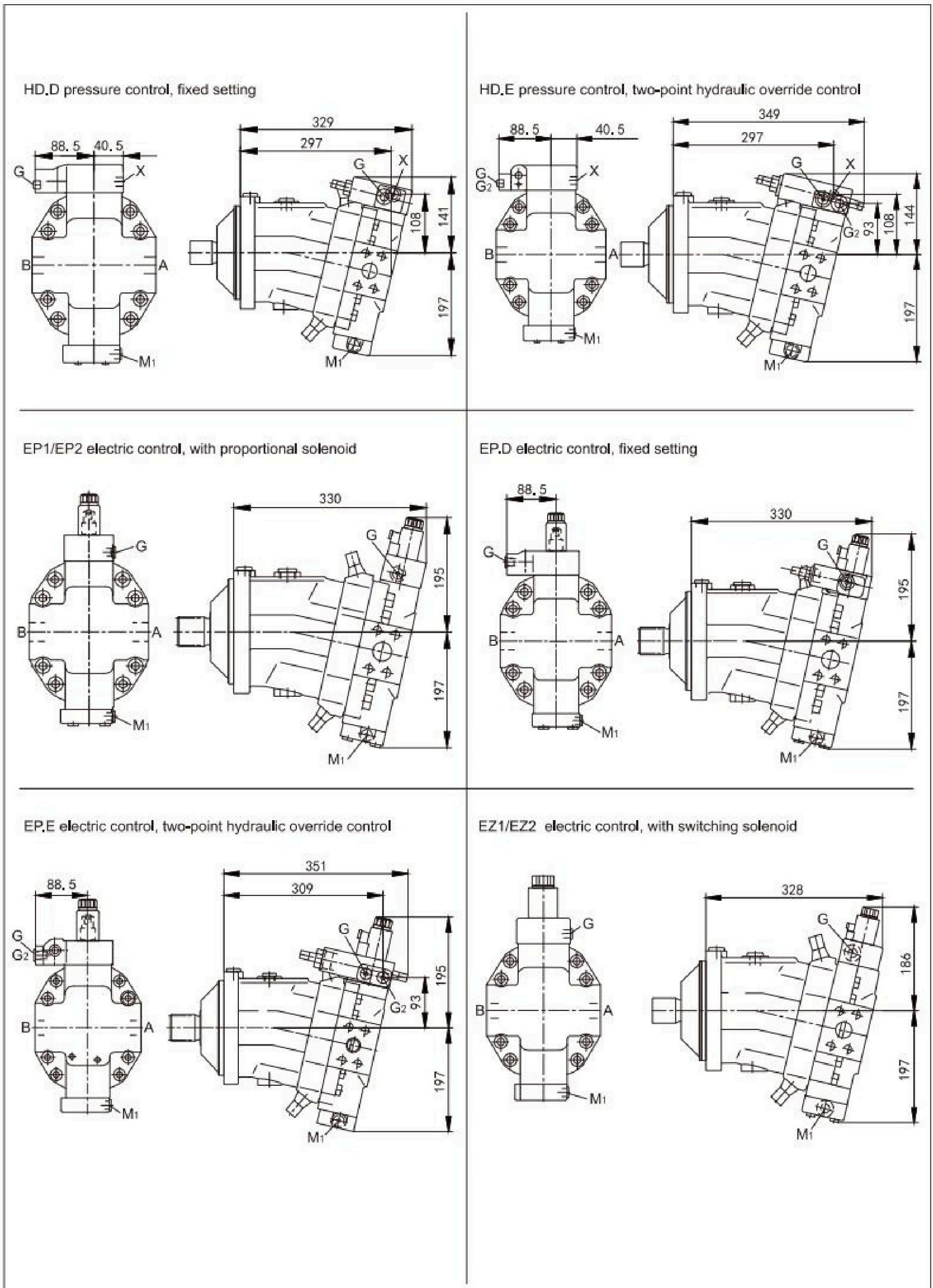



Installation Dimensions

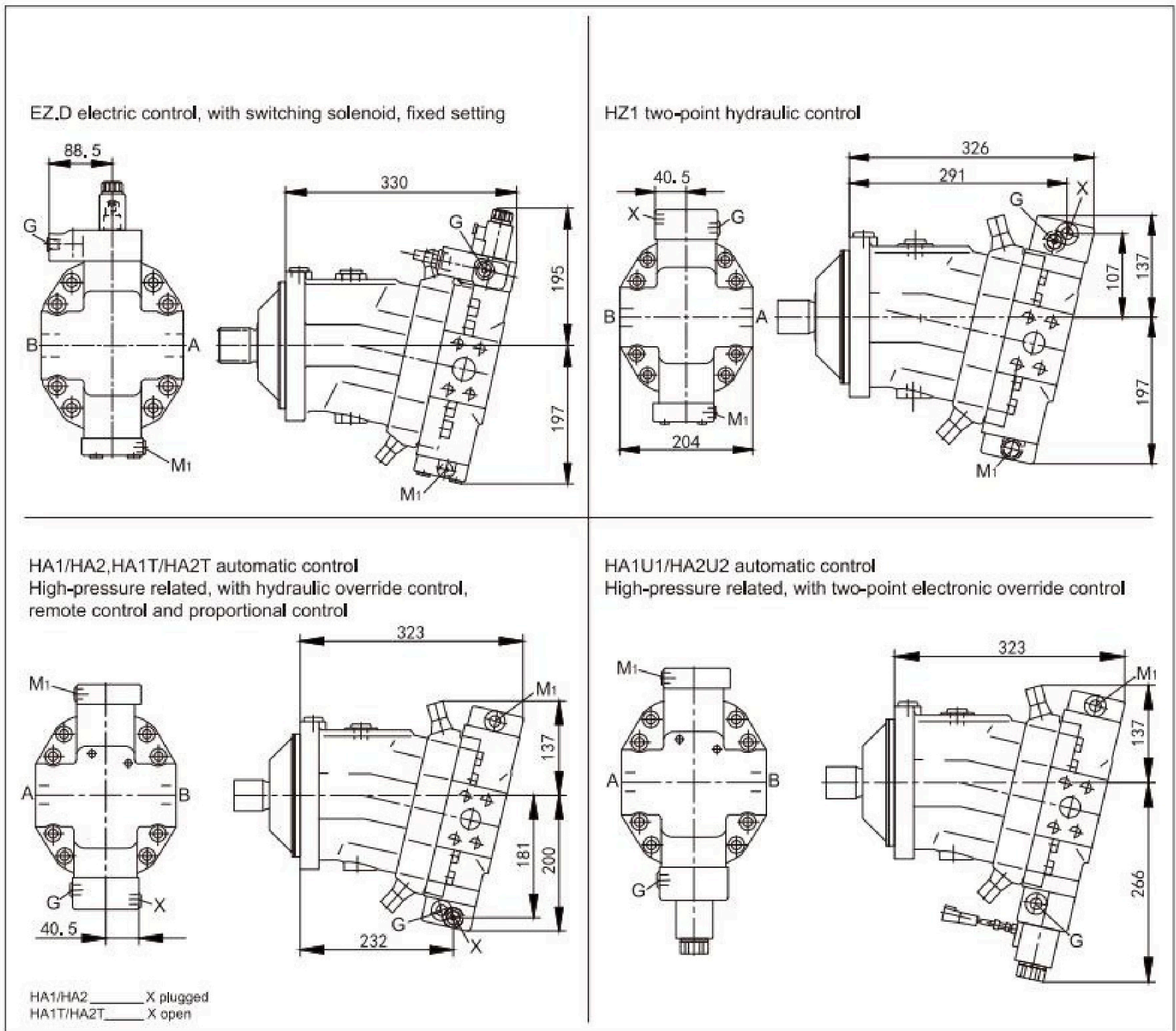



Installation Dimensions

Size 200/215

HD1/HD2 proportional hydraulic control
SAE flange ports A and B at side, opposite(02)

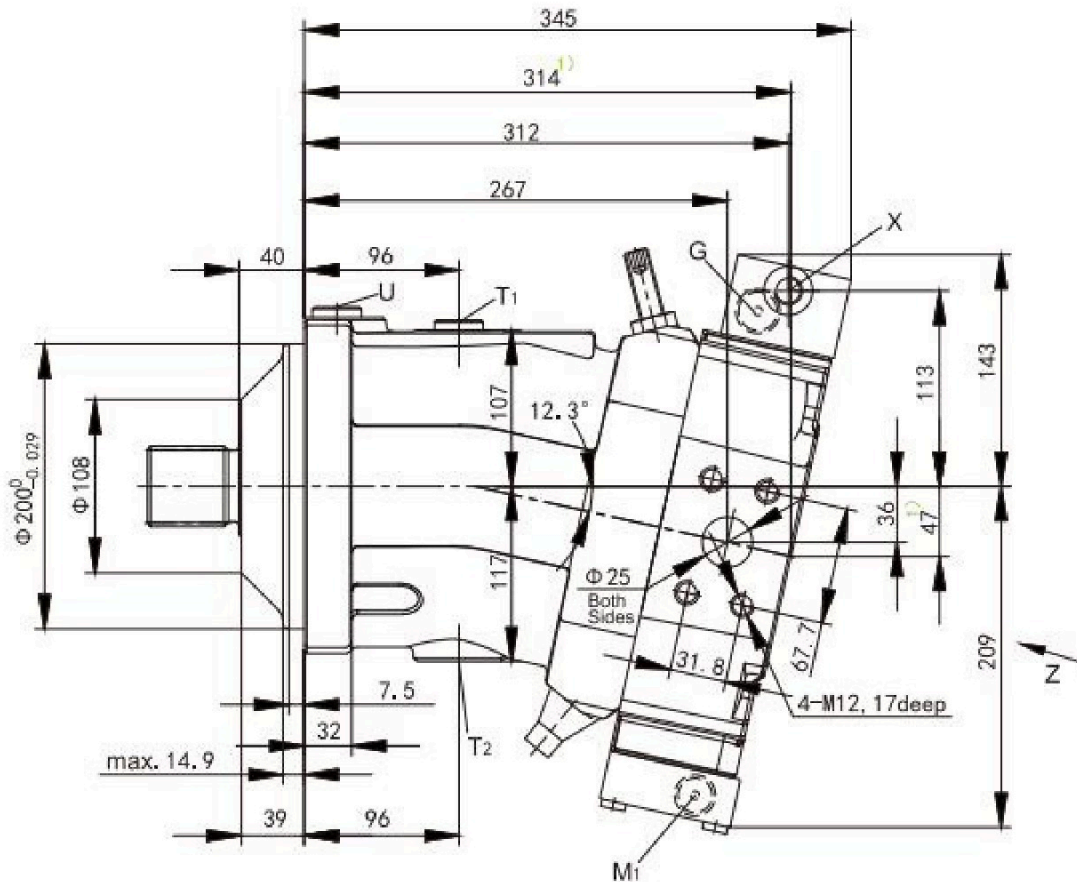

1) Working ports A/B at rear (port plate 01)

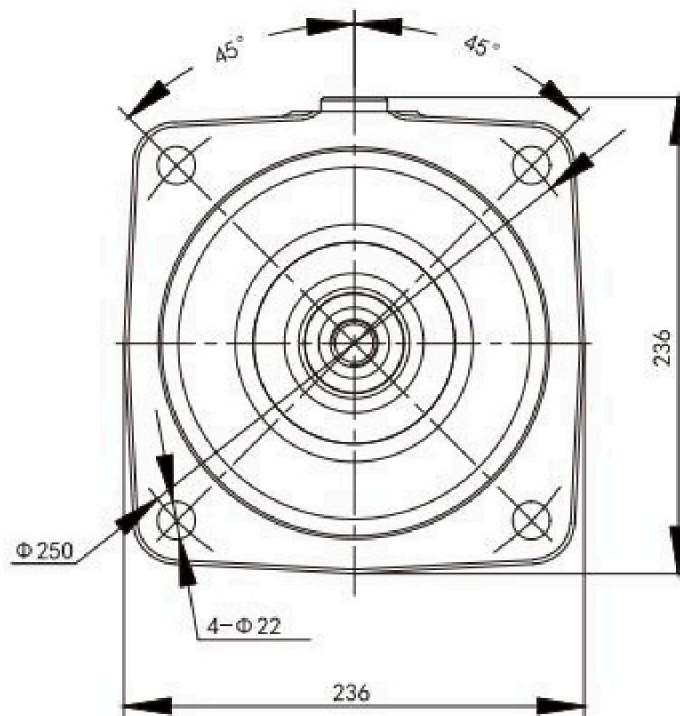



Installation Dimensions

Detail Z

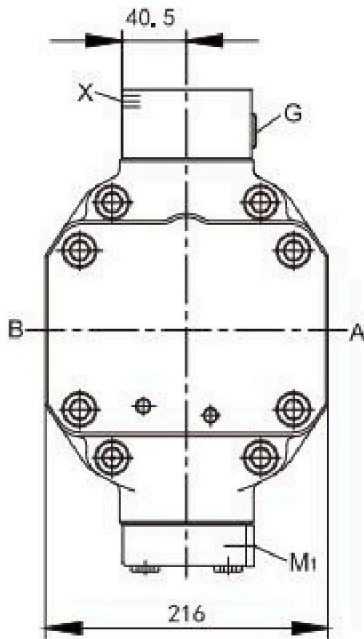

SAE flange ports A/B at side, opposite (02)

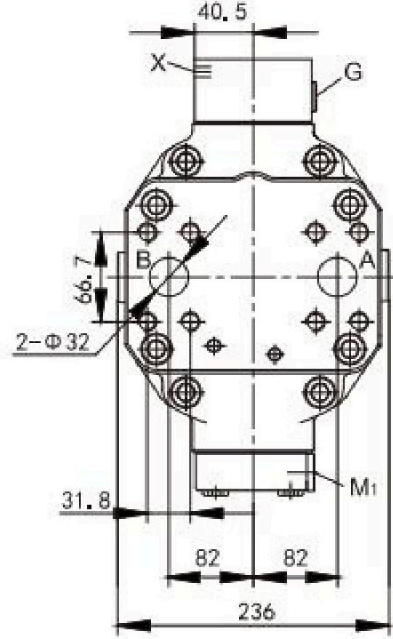

SAE flange ports A/B at rear, opposite(01)

Drive shaft

Splined shaft A DIN 5480
W50x2x30x24x9g

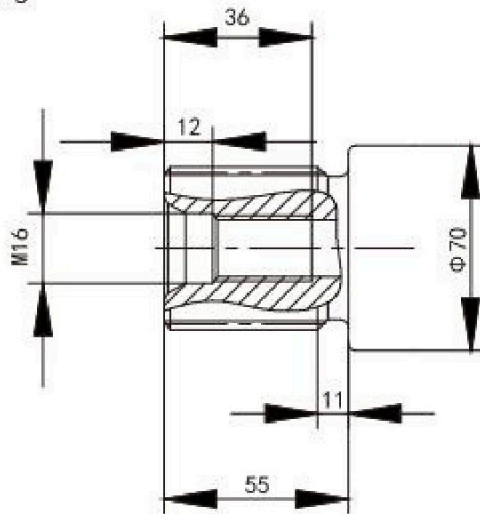

Ports

A/B	Working port (high pressure series)	1 1/4 in
	Fastening thread A/B	M14, 19deep
T1	Case drain port	M26x1.5, 16deep
T2	Case drain port	M26x1.5, 16deep
X	Pilot pressure port	M14x1.5, 12deep
U	Flushing port (plugged)	M22x1.5, 14deep
M1	Control pressure measurement	M14x1.5, 12deep
G	Synchronous control of multiple elements and remote control of pressure	M14x1.5, 12deep
G2	2nd pressure setting (plugged)	M14x1.5, 12deep



Installation Dimensions

HD.D pressure control, fixed setting

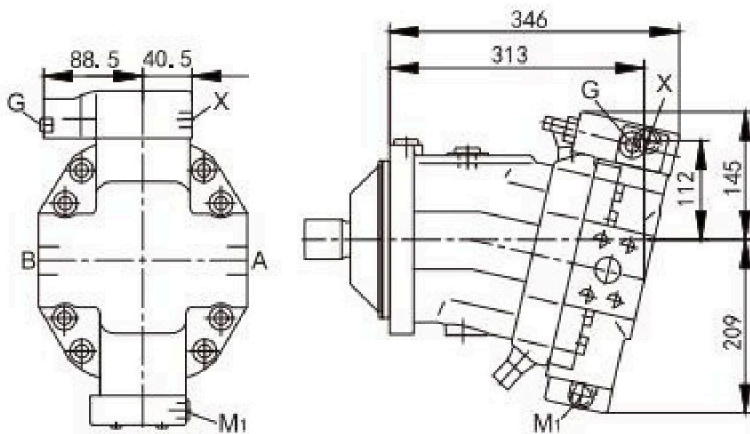

EP.D electric control, fixed setting

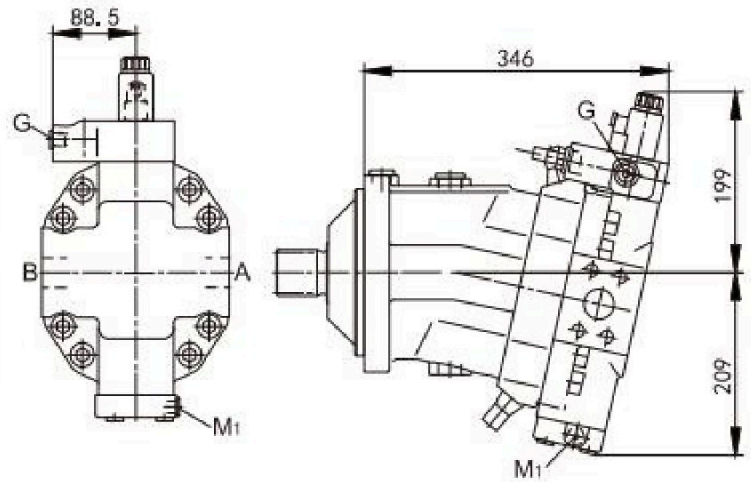

EP1/EP2 electric control, with proportional solenoid

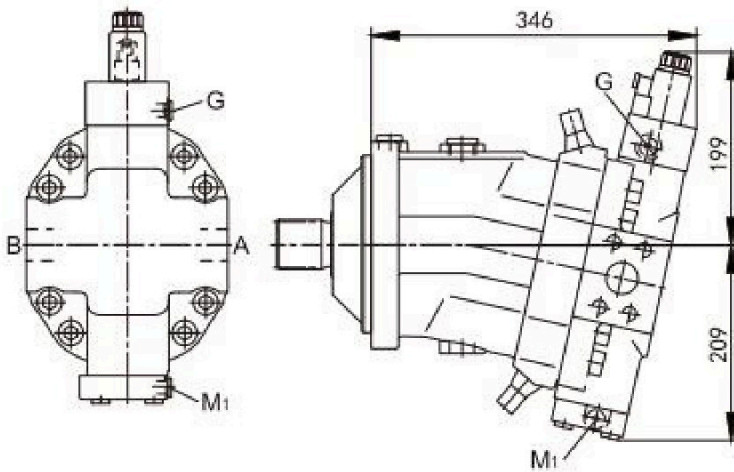

EZ1/EZ2 two-point electric control, with switching solenoid

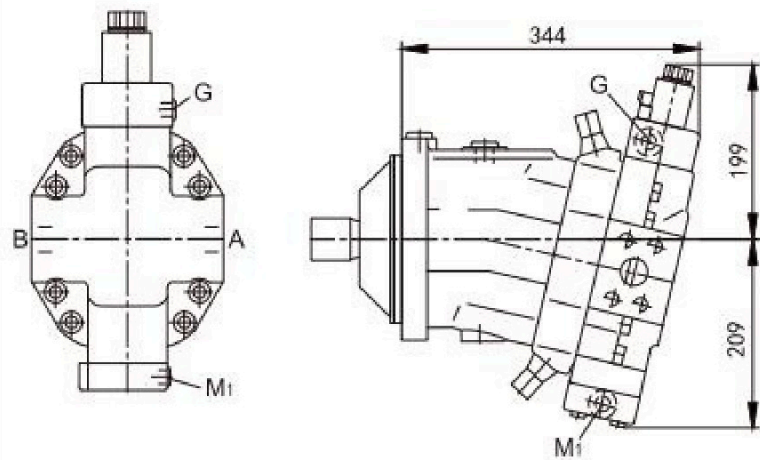

EZ3/EZ4 two-point electric control, with switching solenoid

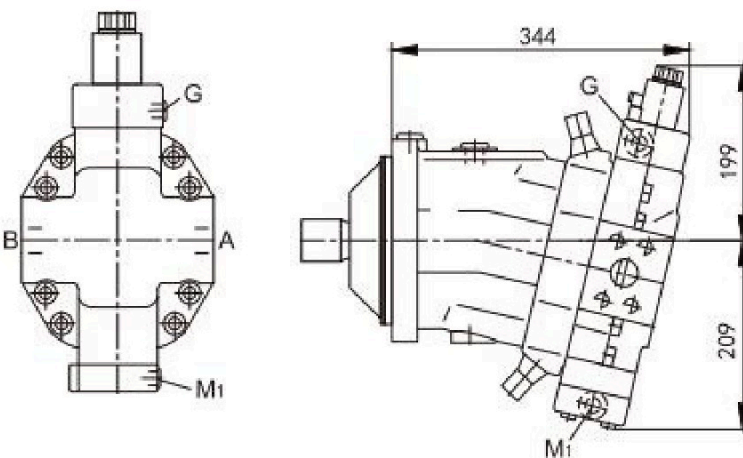

EZ.D electric control, two-point hydraulic override control

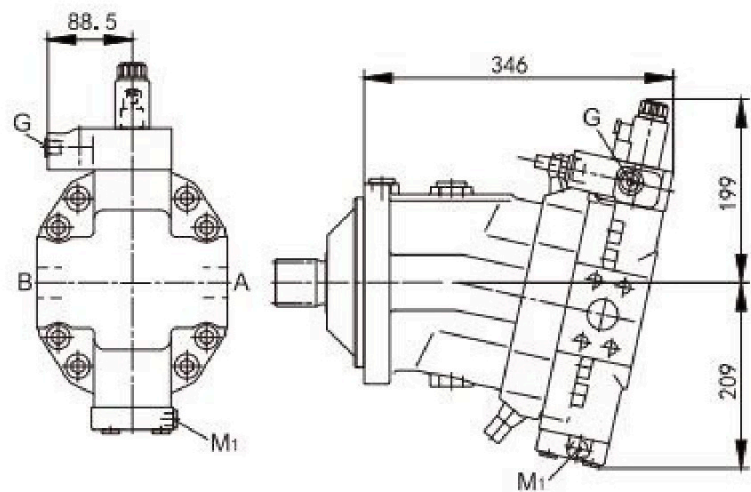



Installation Dimensions

HZ1 two-point hydraulic control

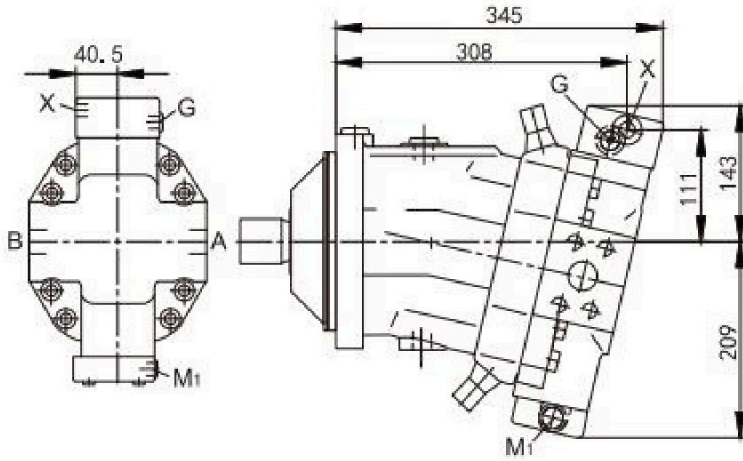

HA1/HA2, HA1T/HA2T automatic control
High-pressure related, with hydraulic override control,
remote control and proportional control

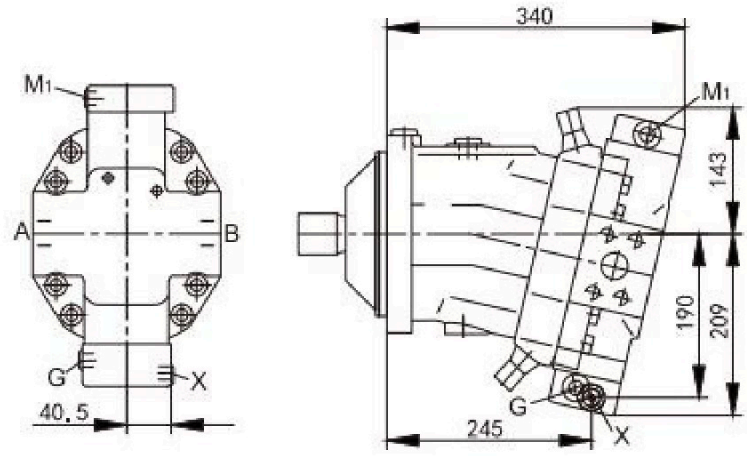

HA1/HA2 _____ X堵住
HA1T/HA2T _____ X打开

HA1U1/HA2U2 automatic control
High-pressure related, with two-point electronic override control

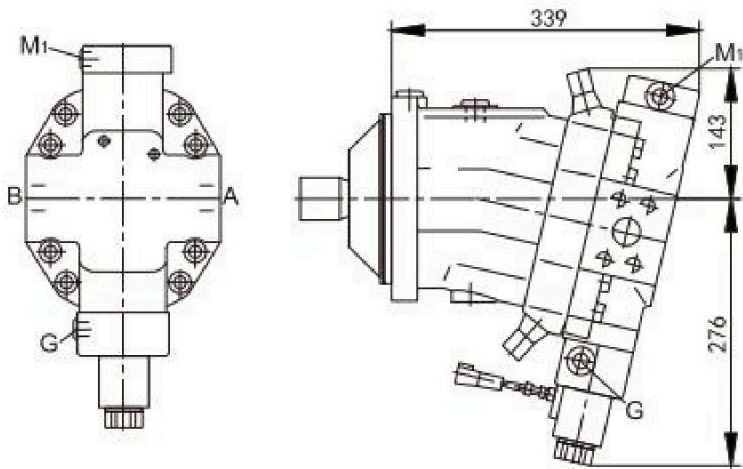



Installation Dimensions

Detail Z

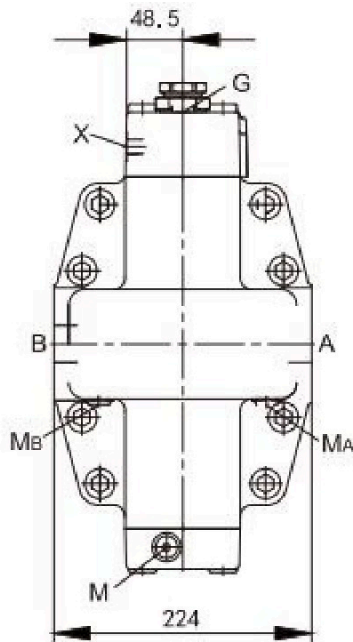

SAE flange ports A/B at side, opposite(02)

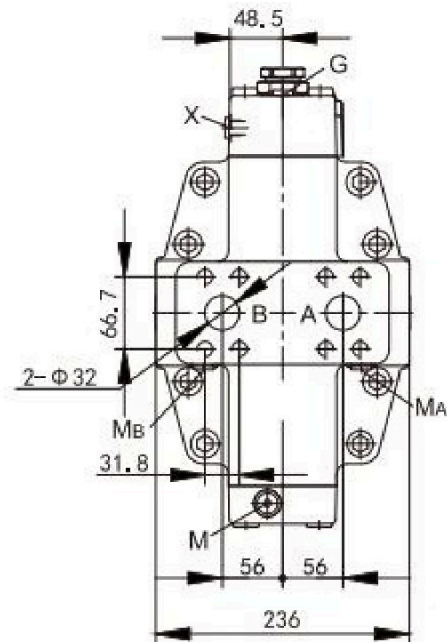

SAE flange ports A/B at rear, opposite(01)

Drive shaft

Splined shaft Z DIN 5480
W50x2x30x24x9g

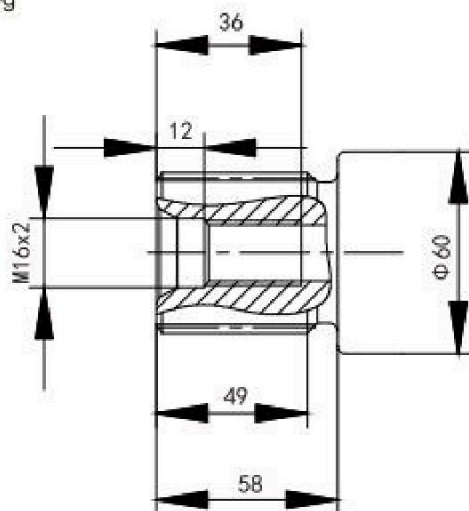

Ports

A/B	Working port	1 1/4 in
	Fastening thread A/B	M14x2, 19deep
T ₁	Case drain port	M22x1.5, 14deep
T ₂	Case drain port	M22x1.5, 14deep
X	Pilot pressure port	M14x1.5, 12deep
U	Flushing port (plugged)	M14x1.5, 12deep
M	Control pressure measurement	M14x1.5, 12deep
M _A /M _B	Control pressure A/B	M14x1.5, 12deep
G	Synchronous control of multiple elements and remote control of pressure	M14x1.5, 12deep
G ₂	2 nd pressure setting (plugged)	M14x1.5, 12deep



Installation Dimensions

HD,D/HD.G pressure control, fixed setting,
hydraulic remote proportional control(HD.G)

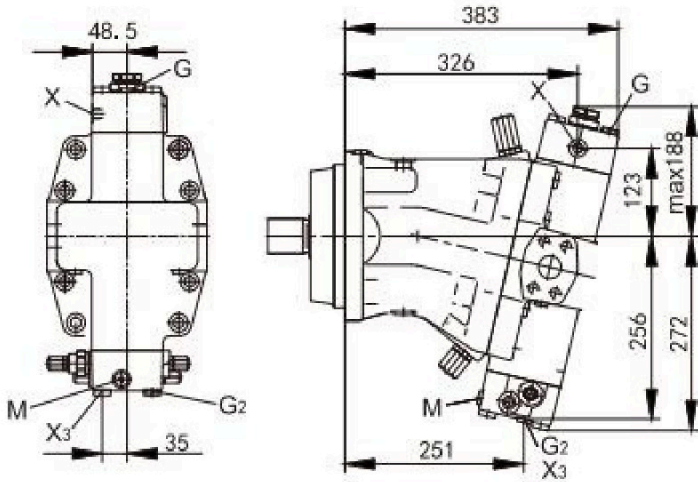

EP1/EP2 electric control, with proportional solenoid

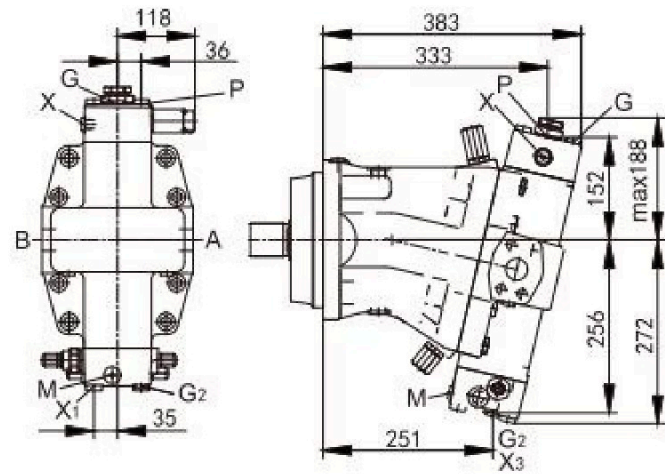

EP.D/EP.G electric control, fixed setting,
proportional hydraulic remote control(EP.G)

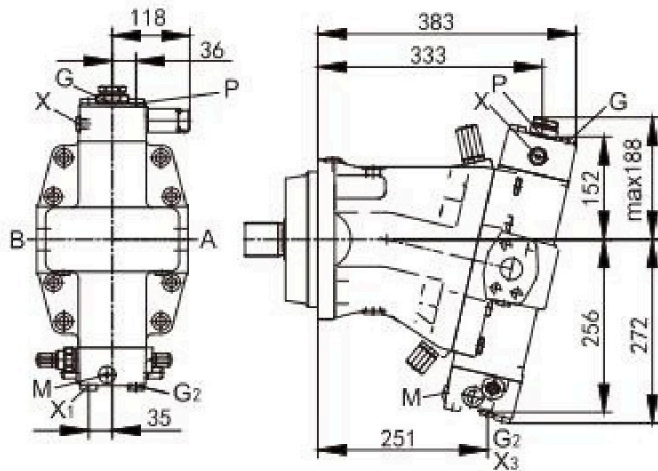

EZ1/EZ2 electric control, with switching solenoid

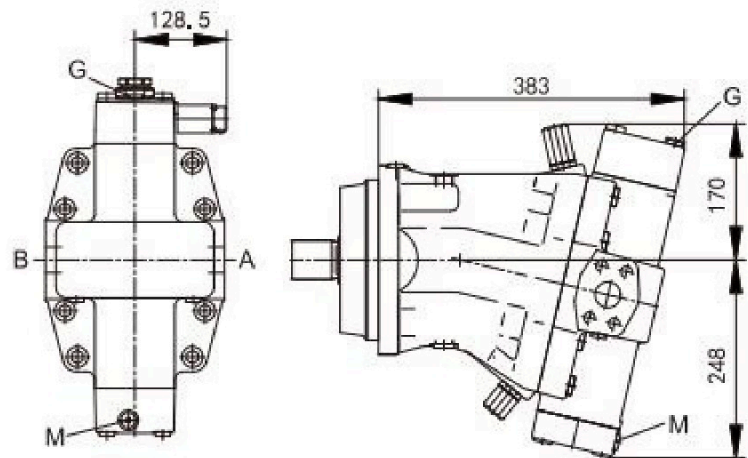

HA1/HA2, HA1T/HA2T automatic control
High-pressure related, with hydraulic override control,
remote control and proportional control

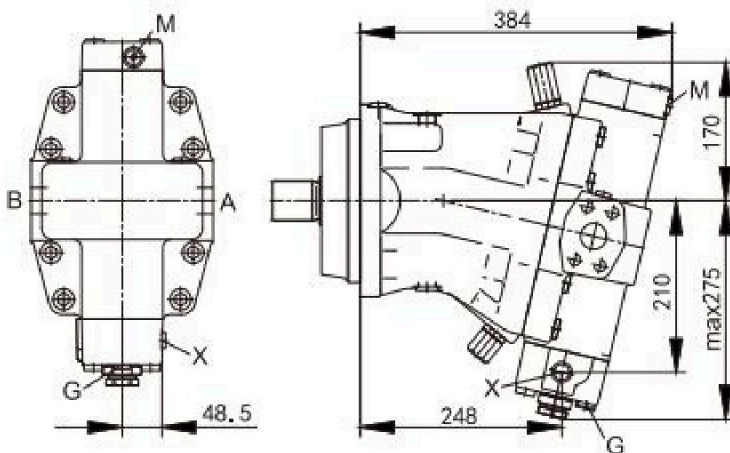



➤ Flushing and Boost-pressure valve

The flushing and boost-pressure valve is used to prevent over-temperature of the closed circuit and to guarantee the minimum boost pressure of the system. (Cracking pressure: 1.6 MPa; fixed setting: note the setting of primary pressure.) It is also used to flush the housing.

Hydraulic fluid is directed from the low-pressure side into the motor housing. Then, it is fed into the reservoir together with the case drain. The removed hydraulic fluid from the closed circuit must be replaced by cooled hydraulic fluid supplied by the boost pump.

In an open circuit, the flushing and boost-pressure valve is used only to flush the housing through the return line. The valve is mounted on the variable motor (or integrated in the control unit depending on the control type and size).

If necessary, a throttle valve may be used to regulate the flow.

➤ Hydraulic Circuit Diagram

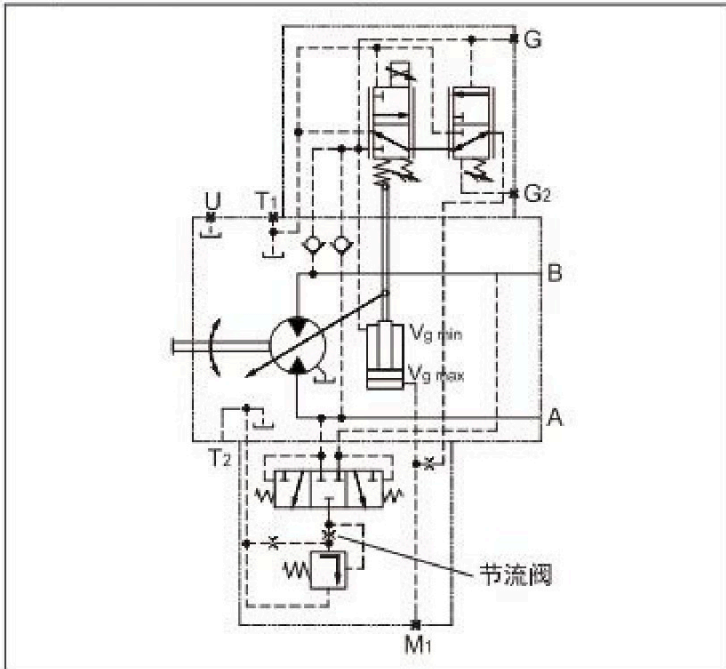

➤ Standard Flow (at low pressure $\Delta p_{LP}=2.5\text{MPa}$)

Size	Flow
28	3.5L/min
55	3.5L/min
80	5L/min
107/115	8L/min
160/170	10L/min
200/215	10L/min
250	10L/min

Throttle valves with flow of 3.5 to 10L/min are available.

If throttle valves of nonstandard flow are required, please specify in detail when ordering.

The flow without throttle valve is approx. 12 to 14L at low pressure $\Delta p_{LP}=2.5\text{MPa}$.

➤ Installation Dimensions

Size 28-215

HA1/HA2

HD/EP/EZ1/EZ2

EZ3/EZ4

Size	A1	A2	A3	A4
28	214	125	161	-
55	-	-	176	236
80	273	142	193	254
107/115	288	144	200	269
160/170	328	154	220	-
200/215	345	160	231	-

Size 250

HD/HZ/DA/EP/EZ

HA1/HA2

Size	A1	A2
250	357	402



Counterbalance valve BVD and BVE

Function

Counterbalance valves for travel drives/winches are designed to reduce the danger of overspeed and cavitation of axial piston motors in open circuits. Cavitation occurs if, during braking, when going downhill or during the load-lowering process, the motor speed is greater than that at the given inlet flow.

If the inlet pressure falls, the counterbalance spool moves to throttle the return flow and brake the motor until the inlet pressure returns to approx. 0.2MPa.

Note

- BVD available for sizes 55 to 200
 - The counterbalance valve must be ordered separately. We recommend ordering the counterbalance valve and the motor as a set.
- Order example:
HA6VM107HA1/63W-VZB378A+HBVD25W38L/41B-V07K00D0800S00A
- For safety reasons, controls with beginning of control at V_{gmin} (e.g. HA) are not permissible for lifting winch drives.
 - Counterbalance valves cannot replace the mechanical service brake and holding brake
 - For the design of the brake release device, we must know the following data for the mechanical holding brake:
 - the cracking pressure
 - the volume of the counterbalance spool between the minimum stroke (brake closed) and maximum stroke (brake released with 2.1MPa)
 - the required closing time for warming up (oil viscosity approx. $15\text{mm}^2/\text{s}$)

Counterbalance valve for travel drives BVD...F

Application

- Travel drives for wheeled excavators

Example code:

HA6VM107HA1/63W-VZB378A+HBVD20F28S/41A-V51R20D0202S00

Counterbalance valve for winches BVD...W and BVE

Application

- Winch drives for cranes(BVD and BVE)
- Track drives for excavators(BVD)

Hydraulic Circuit Diagram

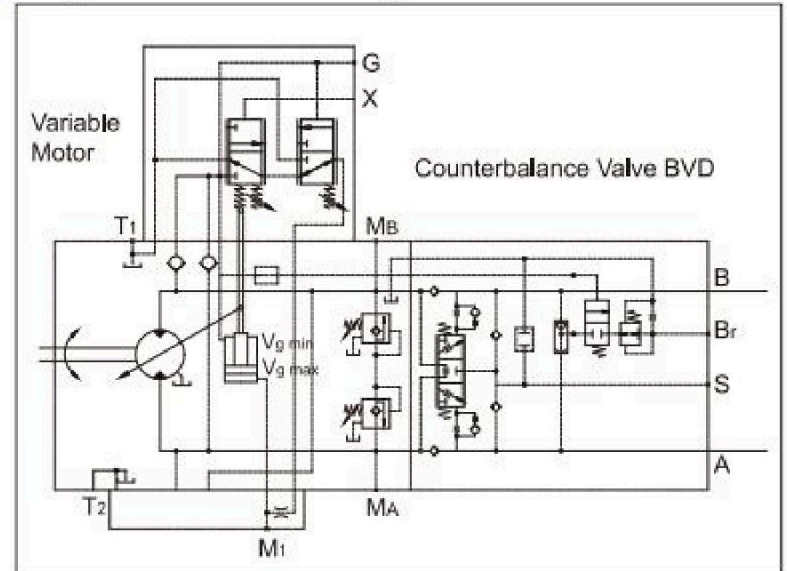



Installation Dimensions-Counterbalance valve

HA6VM...HA

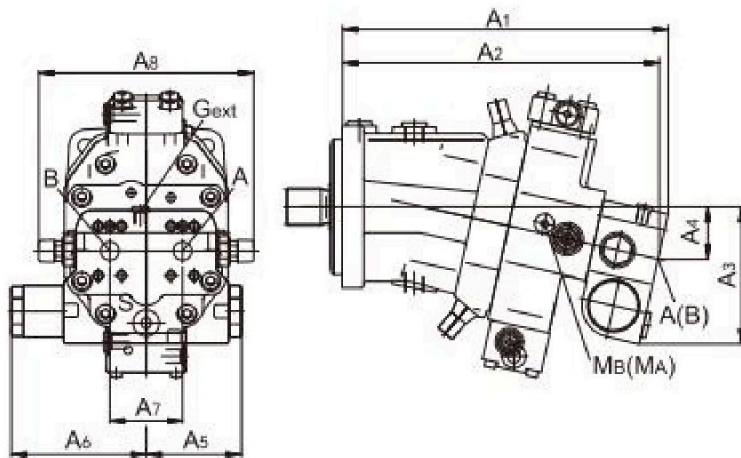

HA6VM...HD或EP¹⁾

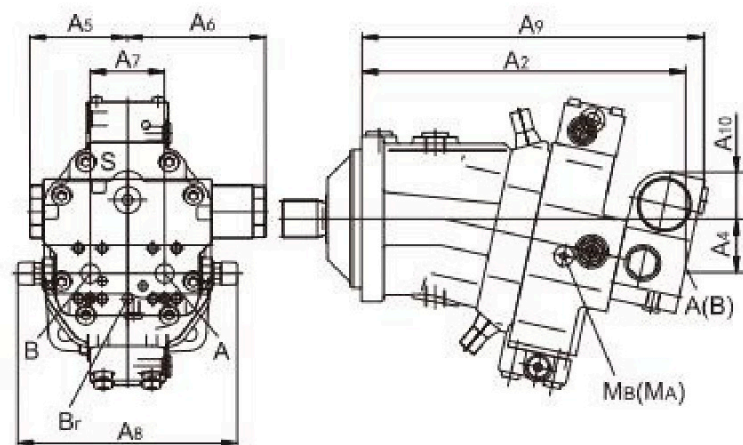

1) At the mounting version for the controls HD and EP, the cast-in port designations A/B on the BVD counterbalance valve do not correspond with the port designation on the wiring diagram of HA6VM motor. The designation of the ports on the installation drawing of the motor shall prevail!

Size	Counterbalance Valve	油口A/B	A ₁	A ₂	A ₃	A ₄	A ₅	A ₆	A ₇	A ₈	A ₉	A ₁₀
55...38	BVD20...17	3/4 in	311	302	143	50	98	139	75	222	326	50
80...38	BVD20...27	1 in	340	331	148	55	98	139	75	222	355	46
107/115...38	BVD20...28	1 in	362	353	152	59	98	139	84	234	377	41
107/115...38	BVD25...38	1 1/4 in	380	370	165	63	120.5	175	84	238	395	56
160/170...38	BVD25...38	1 1/4 in	417	407	170	68	120.5	175	84	238	432	51
200/215...38	BVD25...38	1 1/4 in	448	438	176	74	120.5	175	84	299	463	46
107/115...38	BVE25...38	1 1/4 in	380	370	171	63	137	214	84	238	397	63

Port	Usage	Product	HA6VM Plate	Standard	Size	Max. Pressure (MPa)	State
A/B	Working line			SAE J518	See table above	42	O
S	Boost port	BVD 20		DIN 3852	M22x1.5, 14deep	3	X
		BVD 25		DIN 3852	M27x2, 16deep	3	X
Br	Brake release, reduced high pressure	L	7	DIN 3852	M12x1.5, 12.5deep	3	O
			8	DIN 3852	M12x1.5, 12deep	3	O
Gext	Brake release, high pressure	S		DIN 3852	M12x1.5, 12.5deep	42	X
MA/MB	Pressure measurement A/B			ISO 6149	M18x1.5, 14.5deep	42	X
Note: O=must be connected (plugged on delivery), X=plugged (in normal operation)							



Speed measurement

HA6VM...Fversion ("for speed measurement", without sensor) has teeth on the drive shaft. A signal proportional to the rotational speed is generated as the toothed drive shaft rotates.

The signal is registered by the sensor and transmitted to processing unit.

The F version may be installed on the HDD Hall-effect speed sensor and the sensor is attached to a flat surface with 2 set screws.

Hydraulic Circuit Diagram

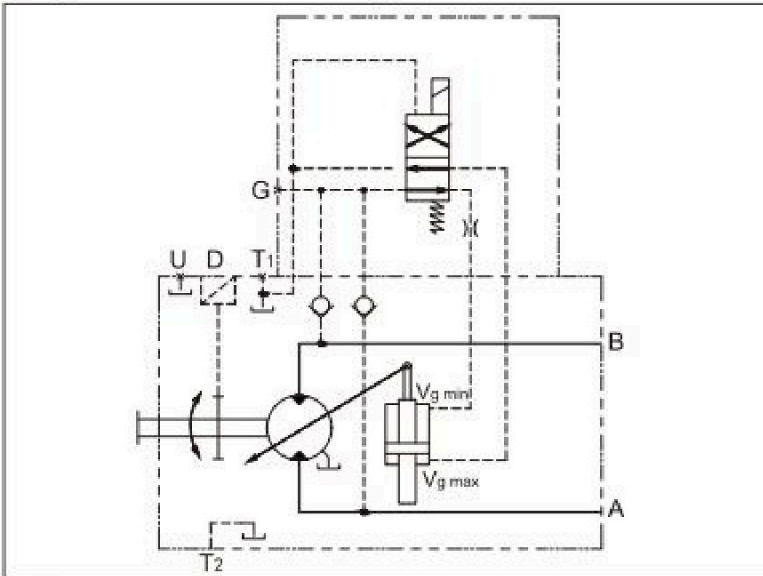

Dimensions

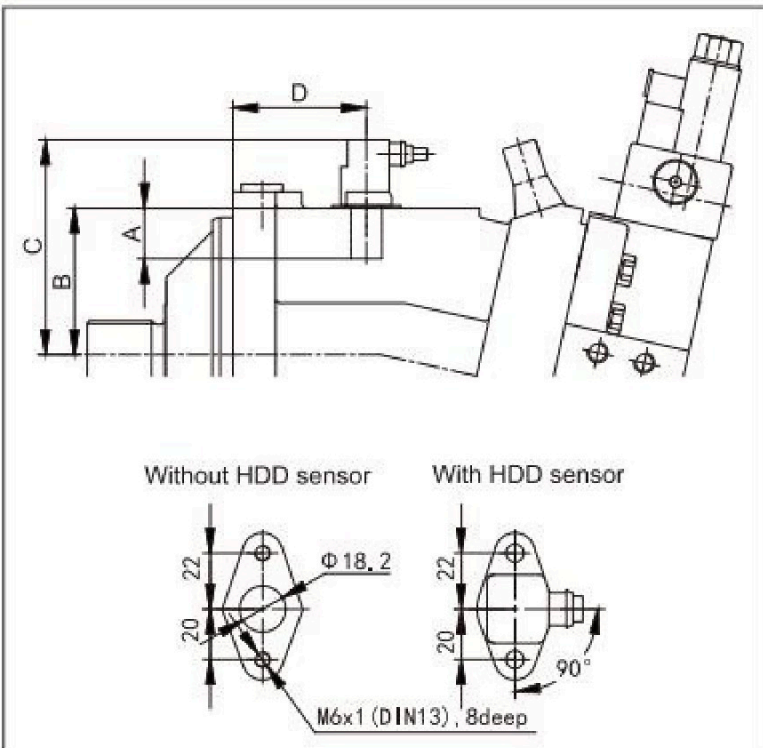

Size		28	55	80	107/115	160/170	200/215	250	
Number of teeth		40	54	58	67	75	80	78	
HDD	A	Insertion depth ±0.1	16	16	16	16	16	16	
	B	Contact surface	60	72.6	76.6	85.6	93.6	98.6	105
	C		98	111	115	124	132	137	143
	D		58	67	76	78	92.5	96	82



Outline Drawings of Speed Sensor

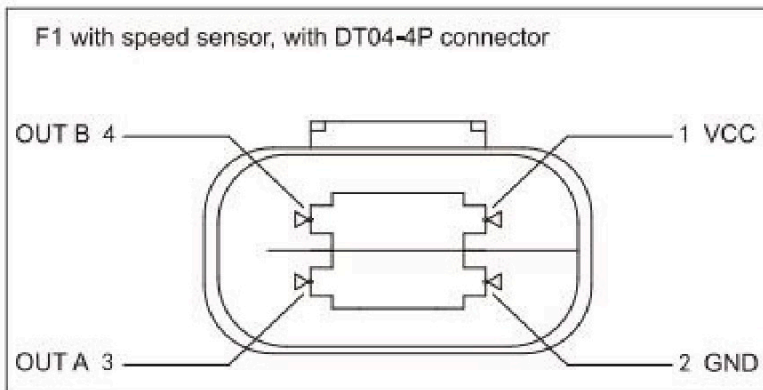
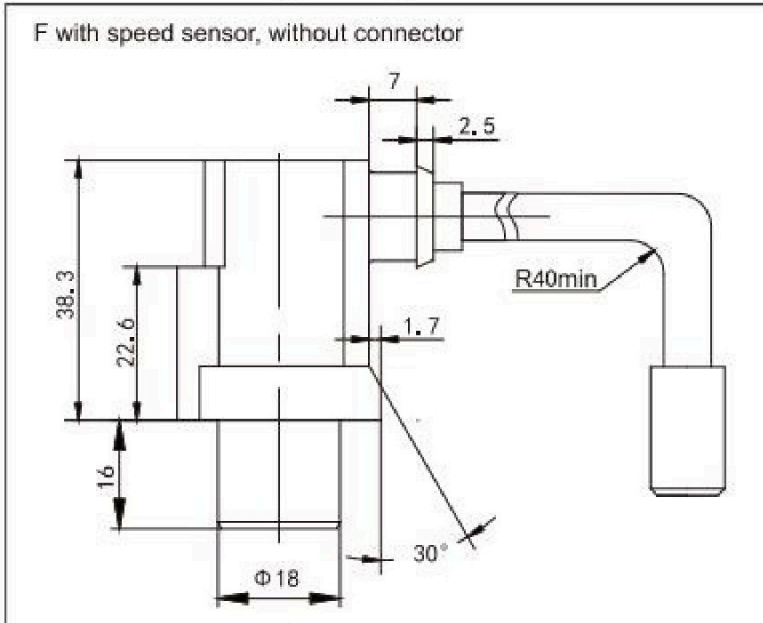

Pins of DT04-4P connector		
Pin	Wire Color	Connected to
1	Brown VCC	Supply voltage
2	Blue GND	Ground
3	Black OUT A	Speed signal (Uf1)
4	White OUT B	Speed signal (Uf2)

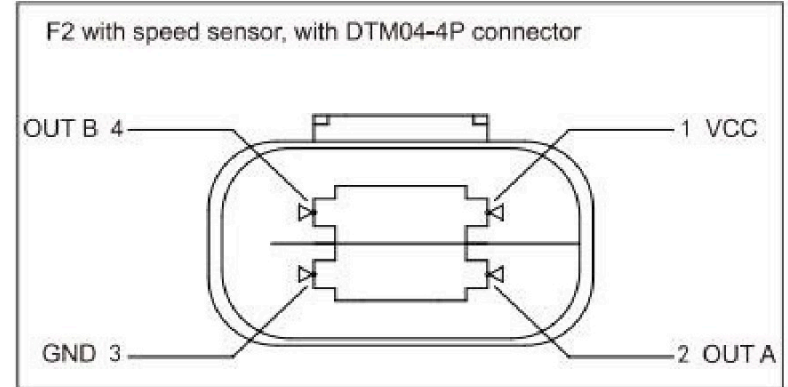

Pins of DTM04-4P connector		
Pin	Wire Color	Connected to
1	Brown VCC	Supply voltage
2	White OUT A	Speed signal A
3	Blue GND	Ground
4	Black OUT B	Speed signal B

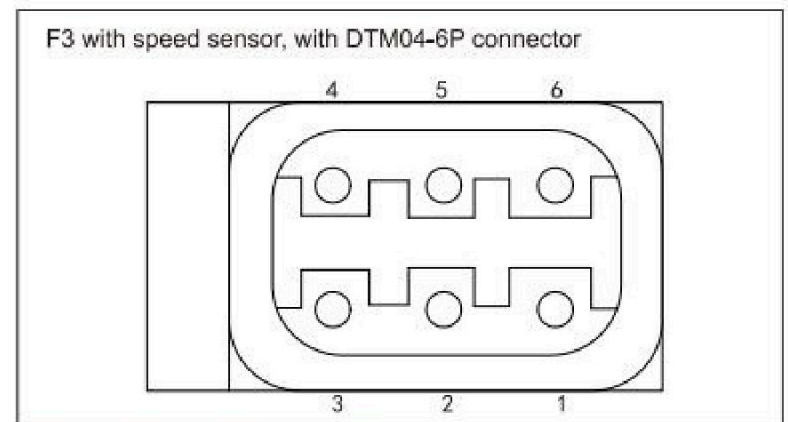

Pins of DTM04-6P connector	
Pin	Signal
1	Speed signal 2
2	Direction signal
3	Speed signal 1
4	Supply voltage
5	Ground
6	Temperature



Installation Instructions

General

The axial piston unit must be filled with hydraulic fluid and air bled during commissioning or operation. This must also be observed following a longer standstill as the system may leak via the hydraulic lines.

The leakage in the housing must be directed to the reservoir via the highest drain port. Under all working conditions, the suction line and the case drain line must flow into the reservoir below the minimum fluid level.

Below-reservoir installation (standard)

The motor is installed below the minimum fluid level of the reservoir.

Recommended installation positions: ① and ②.

Above-reservoir installation

The motor is installed above the minimum fluid level of the reservoir. Note: installation position (shaft upwards)

In this installation position, the hydraulic fluid leaks partially in the housing and the bearings are not sufficiently lubricated.

Hence, a check valve (cracking pressure: 0.05 MPa) should be installed in the case drain line to prevent draining of system via the drain line.

Installation positions

See examples in the figure below. Other installation positions are available upon request.

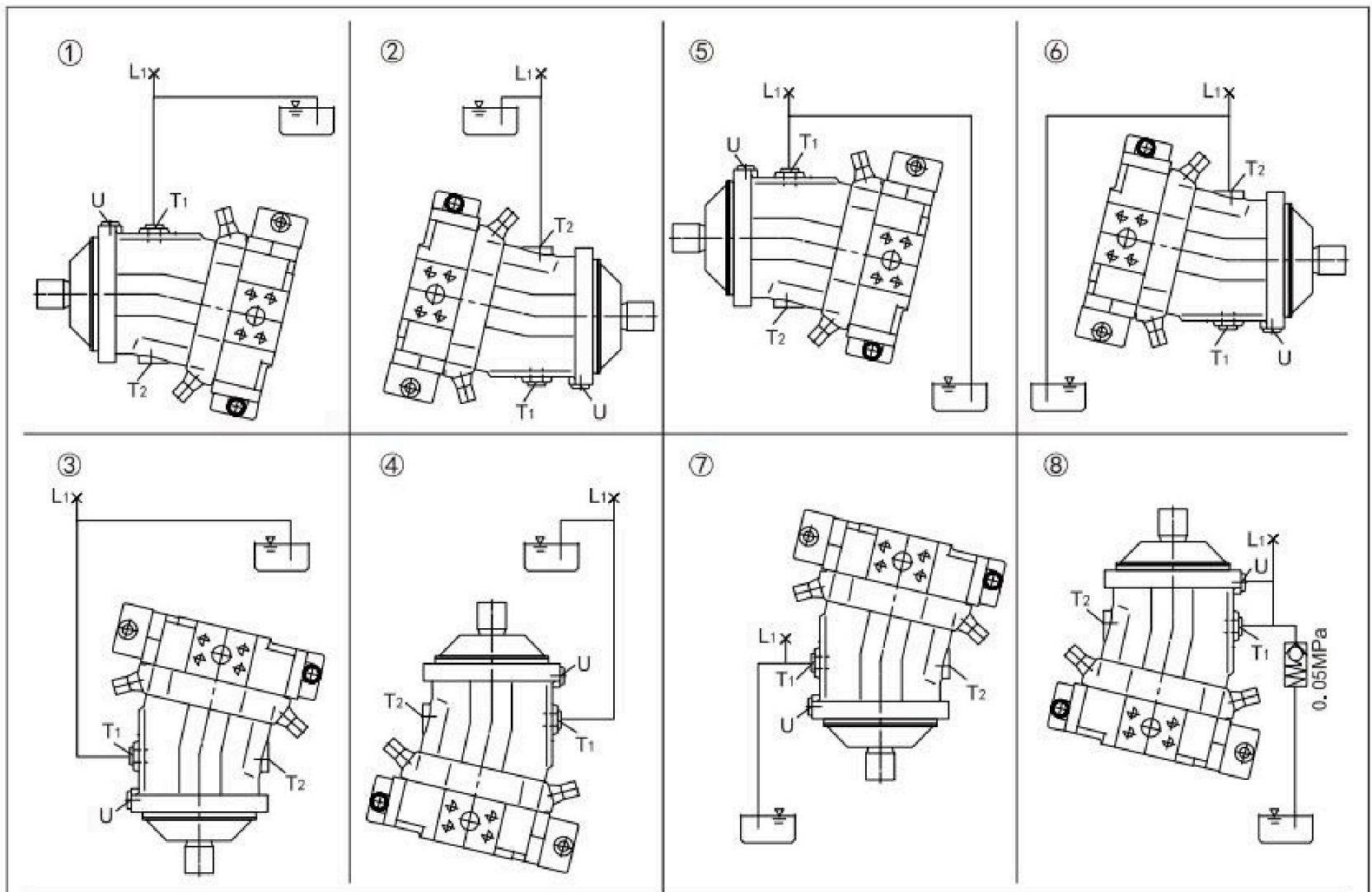

Installation Position	Air Bleed	Filling Port
①	-	T ₁ (L ₁)
②	-	T ₂ (L ₁)
③	-	T ₁ (L ₁)
④	U	T ₁ (L ₁)

Installation Position	Air Bleed	Filling Port
⑤	-	T ₁ (L ₁)
⑥	-	T ₂ (L ₁)
⑦	-	T ₁ (L ₁)
⑧	U	T ₁ (L ₁)







Hytek Power Co., Ltd.

No.156, West Yuele Street, Lucheng District, Wenzhou, Zhejiang, CHINA

+86-577-89615902

globalsales@hytek.cn

www.hytek.cn/en